

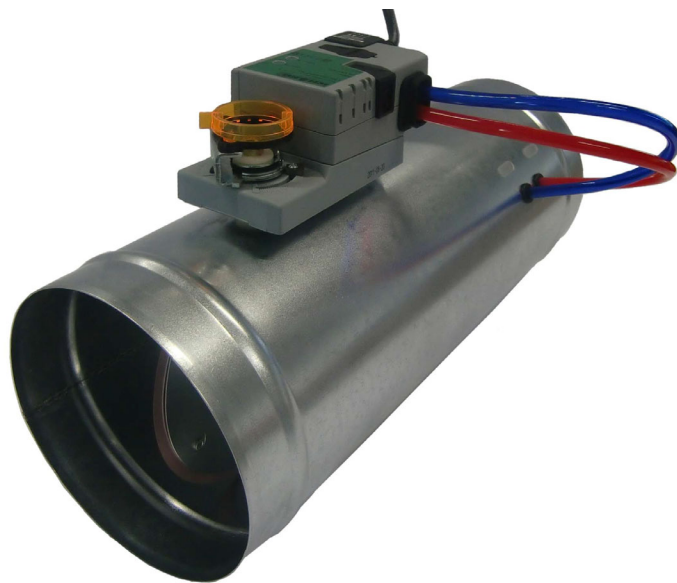

Volumetric flow controller VRAR



Leakage air flow with control damper closed according to DIN EN 1751,
up to class 4 (size NW100-125 class 3) at a duct pressure of up to 1000 Pa.

SCHAKO KG
Steigstraße 25-27
D-78600 Kolbingen
Telephone +49 (0) 74 63 - 980 - 0
Fax +49 (0) 74 63 - 980 - 200
info@schako.de
schako.com

Volumetric flow controller VRAR

Contents

Description	3
Installation	4
Construction	5
Model	5
Accessories	5
Models and dimensions	6
Dimensions	6
Standard controller selection	6
Dimensions of accessories	7
Technical data	9
Volumetric flow range	9
Information for parameterisation	9
Technical data of the control components	22
Circuit diagrams.....	23
Calculation formulas	30
Room pressure control	32
Duct pressure control	32
Supply and return air volumetric flow control	33
Technical data of controllers and motors	34
Functional check	44
Startup using PC-Tool	45
Startup using the setting and diagnostic device ZTH EU (Belimo)	46
Startup using the setting device GUIV-A	47
Differential pressure diagram	48
Controller selection	49
Maintenance and service.....	50
Legend	50
Order code	51
Specification texts	53

Volumetric flow controller VRAR

Description

A volumetric flow controller is used for pressure-independent volumetric flow regulation in ventilation and air-conditioning systems. It is used to keep the volumetric flow constant (CAV) within specified limits or to control it variably (VAV) as a function of a command variable, for example a room temperature controller, DDC or bus system. For constant volumetric flows, the operating stages CLOSED / V_{\min} / V_{mid} / V_{\max} / OPEN are available in stage operation, controlled via relays or switches. The housing, measuring sensor, control flap, PI controller with pressure sensor and actuator form a closed control loop with feedback, allowing demand-dependent, energy-saving air-conditioning of the single rooms or areas of air-conditioning systems. When suitable electrical controller types are used, room or duct pressure regulation can be achieved.

The first adjustment of the V_{\min} , V_{\max} and V_{neff} operating volumetric flows is done prior to delivery ex works in accordance with specific customer requirements, although V_{\min} and V_{\max} can be easily changed at any time with the controller already mounted by means of the handheld control device or the PC-Tool software. When these values are set, the functions of all volumetric flow controllers are also checked. The operating point V_{\max} can be set in the range 20 (30)...100% of the nominal volumetric flow of the box, while the operating point V_{\min} is set in the range 0...100% relative to V_{neff} (depending on the controller types). The maximum deviation of the volumetric flows is +/- 5%, relative to the nominal volumetric flow V_{neff} , based on a calibration curve of 12 m/sec. At lower flow rates, the deviation in percent may increase.

For the calibration of the controllers, a curve with a flow rate of 12 m/ sec is available. For constant-volume volumetric flow controllers, the V_{\min} value will be set to the desired constant-volume value.

If the calibration curve must be changed on site, the controllers must either be recalibrated ex factory or the calibration curve must be changed on site by the customer service of Schako.

For the measurement of the differential pressure, SCHAKO is using its measuring principle by means of a double measuring cross made of extruded aluminium profile, to which 12 measuring points have been attached on the pressure and suction side, respectively, by the median line method, in order to determine average values. In comparison with measuring rods or measuring orifices having fewer measuring points, this gives higher accuracy, allowing the inflow area required in front of the volumetric flow controller to be minimised (see page 4 - Installation).

When using the controllers in systems with heavy dust contamination, suitable filters must be used. For contaminated or aggressive air or air containing fluffy material, only those controller types must be used that incorporate a differential pressure sensor. Since the membrane zero point must not be changed in static sensors, the mounting instructions documented by the manufacturer must be adhered to.

The volumetric flow controllers type VRAR are not suitable for air containing sticky and greasy particles (e.g. kitchen exhaust air).

Housing leakage according to DIN EN 1751, class C, at a duct pressure of up to 1000 Pa.

Leakage with closed damper blade according to DIN EN 1751 class 4 (size NW100-125 class 3) at a duct pressure of up to 1000 Pa.

The volumetric flow controller VRAR has been tested successfully by TÜV SÜD in accordance with the following regulations:

- **VDI 6022, Sheet 1:** Hygienic requirements of ventilation and air-conditioning systems
- **DIN 1946, Sheet 4:** Air-conditioning technology - Health requirements

For maintenance, service, retrofitting, etc., inspection openings in sufficient number and size must be provided on site.

Volumetric flow controller VRAR

Field of application

- for supply and return air systems
- for constant CAV or variable VAV installations.
- for positive control V_{min} , V_{mid} , V_{max} , "OPEN" or "CLOSED"
- For volumetric flow and linear pressure control
- in the differential pressure range 50 - 1,000 Pascal
- at ambient temperatures 0 °C to +50 °C, requirement: measuring air 0 °C to +50 °C / 5...95% relative humidity, non-condensing.
- with command signal 0...10 V DC, 2...10 V DC, via MP bus (Belimo) or Lon, Modbus, KNX, BACnet.
- with supply voltage 24 V AC (19.2...28.8 V) or 24 V DC (21.6...28.8 V)
- with DD varnish coating for aggressive media
- for regulating the air velocity in the duct in the range 1(2)...12 m/s (electric) and 3...12 m/s (pneumatic)
- can also be used with vertical axis

When using volumetric flow controllers in roof central units, in extreme cases, condensation can build up in the measuring pipes of the volumetric flow controller as a result of the large temperature differences between the air flowing through the volumetric flow controller and the surrounding air. This condensation can affect or damage the sensor. This is why for this field of application care must be taken to insulate the housings of the volumetric flow controllers and the measuring hoses (to prevent condensation) and to mount the controllers in such a way that any condensate formed on the outside of the measuring hoses can run downward and be drained (without entering the sensor).

Before connecting SCHAKO components to customer installations, any compatibility problems must be solved on-site and are not our area of responsibility.

Attention: We would like to point out that only suitable cleaning materials may be used for cleaning the stainless steel housings and stainless steel damper leaves!

Installation

To avoid unnecessary controller errors, the min. distances according to the following table / drawings must be observed. For combinations of several connection pieces or pieces with fire dampers or silencers, the larger minimum distances must be observed.

All volumetric flow controllers can be assembled with horizontal or vertical damper axis and are position-independent.

Distance to:	VRAR
Connection piece with bend	1 x diameter
Other connection pieces: (e.g. T-junction, branching piece, reduction piece, etc.)	2 x diameter
Fire damper:	2 x diameter
Silencer (RS-M):	2 x diameter

Installation information

Distance to a bent connection spigot

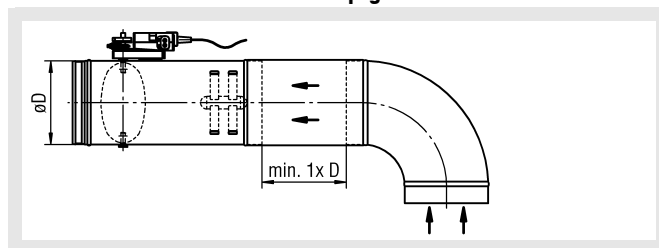

Distance to other connection pieces

(e.g. branching piece, reducing piece, T-junction, etc.)

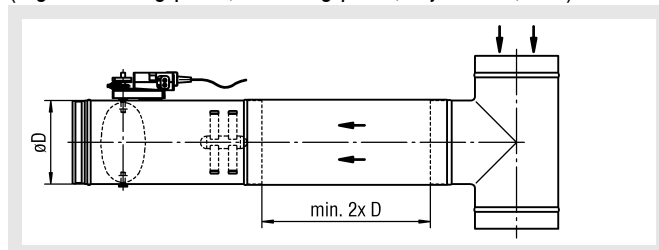

Distance to a fire damper

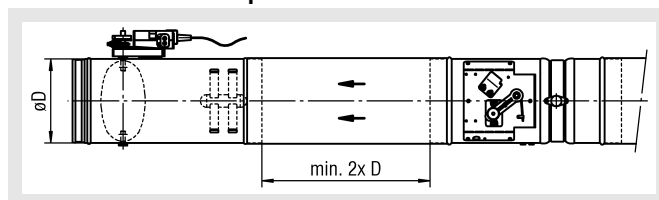

Distance to a silencer with intermediate baffle (RS-M)

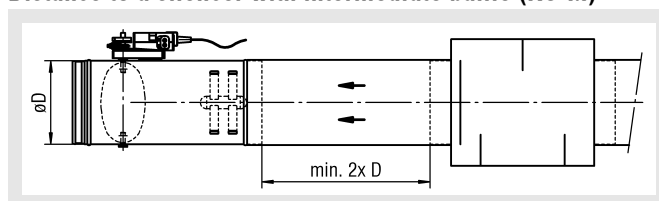

D = diameter

Volumetric flow controller VRAR

Construction

Housing

- Galvanised sheet steel (-SV)
- Galvanised sheet steel with DD coating inside (-DD)
- Stainless steel 1.4301 (-V2) or 1.4571 (-V4)

Damper blade

- Galvanised sheet steel (-SV)
- Stainless steel 1.4301 (-V2A) or 1.4571 (-V4A)

Damper leaf seal

- made of PUR, silicone-free
- for airtight sealing design to DIN EN 1751

Damper bearing

- Brass

Measuring cross

- Extruded aluminium profile (for stainless steel design with DD coating)

Measuring cross support

- Plastic (PA6)

Model

- VRAR-... - round design, for spiral duct connection to DIN EN 1506, with damper leaf seal for airtight sealing to DIN EN 1751 (class 2 NW100 only, class 3 NW125 - 630 only).
 - Housing leakage according to DIN EN 1751, class B, at a duct pressure of up to 1000 Pa.
- ...-A... - with electric controller
 - Control voltage 24 V AC, 50/60 Hz
 - alternatively with spring return actuator zero-current "CLOSED" or zero-current "OPEN" (at an extra charge).
 - alternatively with high-speed actuator running time 3-5 sec. for 90° angle of rotation (at an extra charge).
- with pneumatic controller
 - in the design depressurised "CLOSED" (standard) or depressurised "OPEN".
 - Feed pressure 1.2 ± 0.1 bar

Accessories

Acoustic cladding (-DS 2)

- made of sound-absorbing, insulating 20 mm material with sheet steel covering made of galvanised sheet steel, non-flammable according to DIN 4102-17.

Flat-bed acoustic cladding (-FD1)

- made of sound-absorbing, insulating 3 mm material with sheet steel casing made of galvanised sheet steel (standard)

Rubber lip seal (-GD1)

- on both sides, made of special rubber.

Flat flange (pair)

- on both sides, according to DIN 24 154/5
- made of galvanised steel (-FF1)
- made of stainless steel V2A / 1.4301 (-FF2)

Metu flange (pair)

- on both sides
- made of galvanised steel (-MF1)
- made of stainless steel V2A / 1.4301 (-MF2)

Tension ring (pair), loose

- on both sides, to connect Metu flange to counter flange.
- made of galvanised steel (-SR1)
- made of stainless steel V2A / 1.4301 (-SR2)

Counter flange (pair), loose

- On both sides, to Metu flange
- made of galvanised steel (-GF1)
- made of stainless steel V2A / 1.4301 (-GF2)

Duct silencer (-RS-N)

- Rigid design
- outer jacket and perforated sheet made of galvanised sheet steel
- Mineral wool lining

Please note!

Tension rings, counter flanges and duct silencers must be ordered separately and are supplied loose!

Volumetric flow controller VRAR

Models and dimensions

Dimensions

with electric controller

VRAR-...-DS0, without acoustic cladding

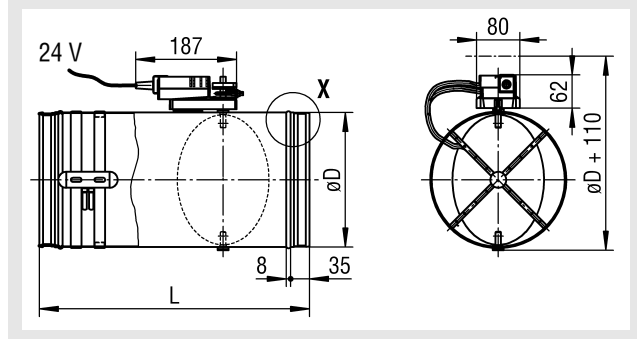

with pneumatic controller

VRAR-...-DS0, without acoustic cladding

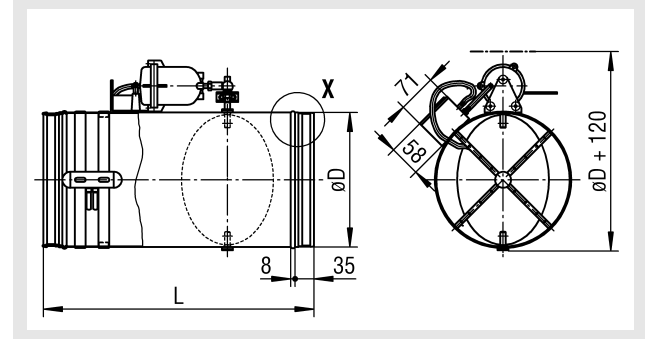

VRAR-...-DS2, with acoustic cladding 20mm

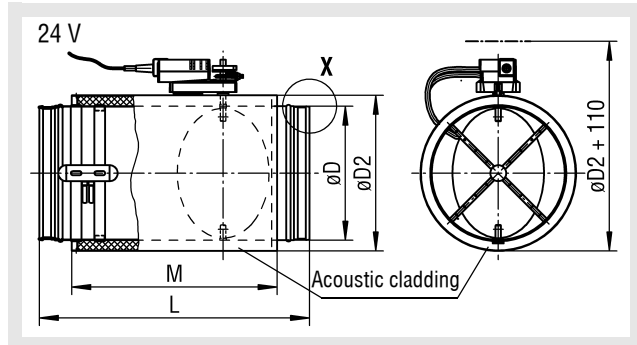

VRAR-...-DS2, with acoustic cladding 20mm

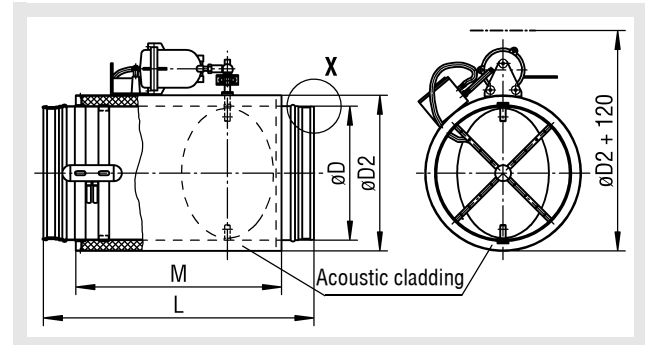

VRAR-...-FD1, with flat-bed acoustic cladding

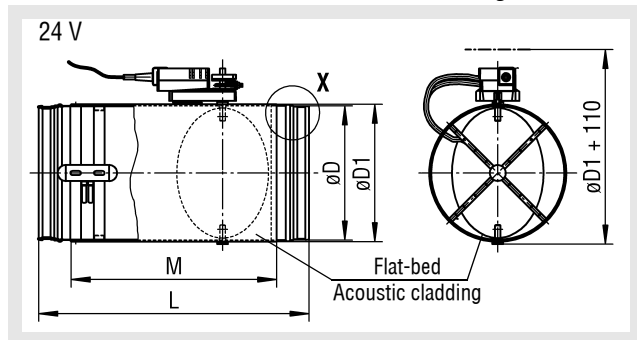

VRAR-...-FD1, with flat-bed acoustic cladding

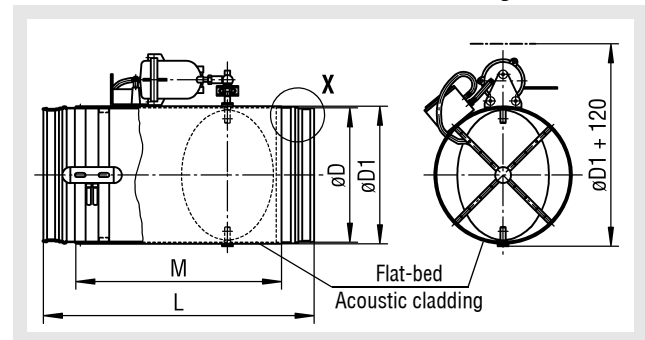

Available sizes VRAR-...

NW	øD	øD1	øD2	L	M
100	98	104	140	340	270
125	123	129	165	360	290
160	158	164	200	410	325
200	198	204	240	450	340
225	223	229	265	475	355
250	248	254	290	500	380
280	278	284	320	550	430
315	313	319	355	600	480
355	353	359	395	650	530
400	398	404	440	700	580
500	498	504	540	850	730
630	628	634	670	950	830

Leakage with closed damper blade according to DIN EN 1751 class 4 (size NW100-125 class 3) at a duct pressure of up to 1000 Pa.

Standard controller selection

with electric controller:

NW	Attachment as- sembly	Controller / Drive	Actuator
100 - 400	-A001	LMV-D3-MP-F1	Compact
500 - 630	-A002	NMV-D3-MP-F1	Compact

The listed compact controllers are compatible with the older generation of types LMV-D2M and NMV-D2M.

with pneumatic controller:

NW	Attachment as- sembly	Controller / Drive	Actuator
100 - 400	-A106	RLP100 F003	AK31P1 F001
500 - 630	-A107	RLP100 F003	AK42P F003

Volumetric flow controller VRAR

Accessories - dimensions

Rubber lip seal (-GD1), on both sides
Detail X

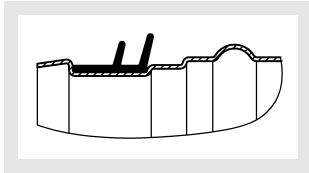

Flat flange (-FF1/-FF2, pair), on both sides
according to DIN 24 154/5

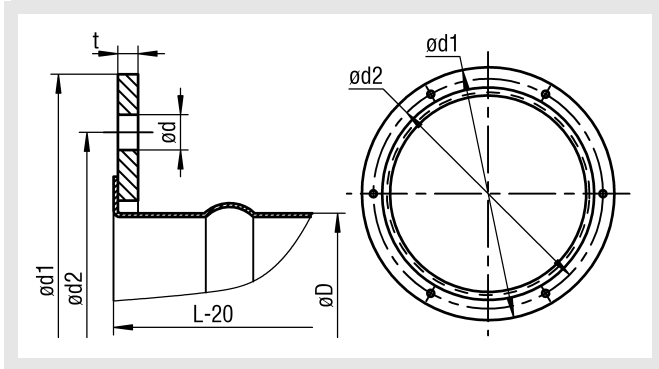

Available sizes flat flange (-FF1/-FF2)

NW	øD	ød1	ød2	ød	L	LOA	t
100	98	154	129	7	340	4	3
125	123	177	155	7	360	4	3
160	158	222	194	7	410	6	4
200	198	263	235	7	450	6	4
225	223	287	259	7	475	6	4
250	248	313	286	7	500	6	4
280	278	353	322	9,5	550	8	5
315	313	388	356	9,5	600	8	5
355	353	428	395	9,5	650	8	5
400	398	474	438	9,5	700	12	5
500	498	574	541	9,5	850	12	5
630	628	726	698	11,5	950	16	6

Metu flange (-MF1/-MF2, pair), on both sides

Counter flange (-GF1/-GF2, pair), on both sides, loose

Tension ring (-SR1/-SR2, pair), on both sides, loose

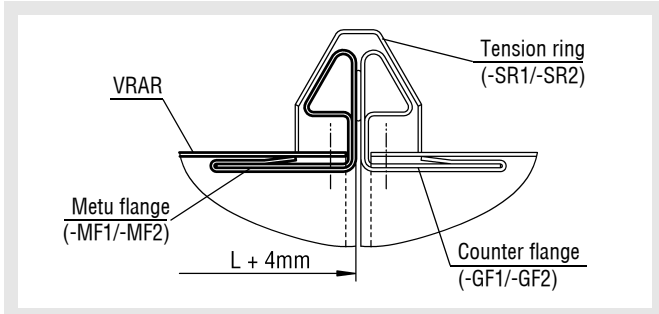

Please note!

Tension rings and counter flanges must be ordered separately
and are supplied loose!

Duct silencer (-RS-N)

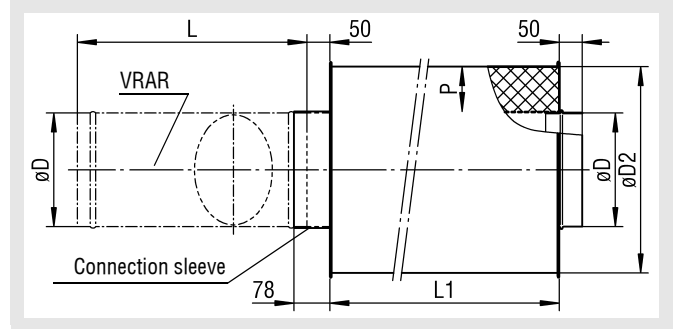

Please note!

Duct silencers must be ordered separately!

For further information, see duct silencer RS documentation.

Available sizes duct silencer (-RS-N)

NW	L (VRAR)	øD	øD2 P (mm)	
			50	100
100	340	98	200	300
125	360	123	225	325
160	410	158	260	360
200	450	198	300	400
225	475	222	325	425
250	500	248	350	450
280	550	278	380	480
315	600	313	415	515
355	650	353	455	555
400	700	398	500	600
500	850	498	-	700
630	950	628	-	830

Selection chart packing thickness duct silencer (-RS-N)

NW	L1=500 P (mm)		L1=950 P (mm)		L1=1450 P (mm)		L1=1950 P (mm)	
	50	100	50	100	50	100	50	100
100	X	X	X	X	X	--	X	--
125	X	X	X	X	X	--	X	--
160	X	X	X	X	X	X	--	X
200	X	X	X	X	X	X	--	X
225	X	X	X	X	X	X	--	X
250	X	X	X	X	X	X	--	X
280	X	X	X	X	X	X	--	--
315	X	X	X	X	X	X	--	--
355	X	X	X	X	X	X	--	--
400	X	X	X	X	X	X	--	--
500	--	--	--	X	--	X	--	--
630	--	--	--	--	--	X	--	--

X = available

-- = not available

Volumetric flow controller VRAR

Insertion loss
Duct silencer (-RS-N)

RS-N-...-50/100, L1=500, without central baffle

NW	D _e (dB/oct)															
	P=50								P=100							
	f _m (Hz)								f _m (Hz)							
	63	125	250	500	1000	2000	4000	8000	63	125	250	500	1000	2000	4000	8000
100	3	6	10	16	22	30	14	13	5	13	15	19	33	31	25	15
125	3	5	9	14	20	24	12	11	4	10	13	18	29	25	18	12
160	2	4	7	12	18	19	10	9	3	9	11	16	26	19	14	10
200	1	3	6	10	16	15	7	6	3	7	9	15	25	17	11	9
225	1	3	5	9	15	13	6	5	3	6	9	15	24	16	10	8
250	1	2	4	9	15	11	4	3	2	6	8	14	23	15	9	7
280	1	2	4	8	14	10	4	2	2	5	7	14	21	14	8	6
315	1	1	3	8	12	8	3	2	2	4	7	13	20	12	7	5
355	1	1	3	7	11	7	3	1	2	3	6	13	19	10	6	4
400	1	1	3	7	10	7	2	1	1	3	6	12	18	9	4	4
500	--	--	--	--	--	--	--	--	--	--	--	--	--	--	--	--
630	--	--	--	--	--	--	--	--	--	--	--	--	--	--	--	--

RS-N-...-50/100, L1=1450, without central baffle

NW	D _e (dB/oct)															
	P=50								P=100							
	f _m (Hz)								f _m (Hz)							
	63	125	250	500	1000	2000	4000	8000	63	125	250	500	1000	2000	4000	8000
100	8	22	44	50	50	50	46	28	--	--	--	--	--	--	--	--
125	7	20	39	50	50	50	39	25	--	--	--	--	--	--	--	--
160	6	14	27	42	48	42	26	18	6	17	30	47	50	49	30	18
200	4	6	15	29	42	30	17	14	5	14	26	42	50	46	28	16
225	3	5	12	23	39	28	15	12	5	13	24	38	49	44	26	15
250	3	4	10	20	37	24	13	11	4	12	22	36	46	43	25	14
280	2	4	9	18	35	22	12	9	3	10	18	30	39	35	20	10
315	2	4	8	16	34	19	10	7	2	8	15	27	35	32	17	9
355	1	3	7	15	28	15	9	5	2	7	14	25	32	28	15	7
400	1	2	6	15	27	13	8	5	2	6	12	23	30	25	13	7
500	--	--	--	--	--	--	--	--	1	4	9	18	25	20	10	5
630	--	--	--	--	--	--	--	--	1	2	6	13	18	12	6	4

RS-N-...-50/100, L1=950, without central baffle

NW	D _e (dB/oct)															
	P=50								P=100							
	f _m (Hz)								f _m (Hz)							
	63	125	250	500	1000	2000	4000	8000	63	125	250	500	1000	2000	4000	8000
100	5	12	23	36	50	50	34	21	7	19	28	40	50	50	50	32
125	4	11	21	33	50	50	32	19	6	17	25	34	49	50	36	22
160	3	8	15	23	34	29	18	14	5	12	18	28	41	48	26	16
200	2	5	11	18	30	24	14	11	4	10	15	24	35	41	22	13
225	2	4	10	17	29	20	12	10	3	9	14	22	33	38	21	12
250	2	4	9	15	27	18	11	9	3	8	13	20	31	35	20	11
280	2	3	7	13	25	15	8	7	3	6	10	17	29	32	18	9
315	1	3	6	12	24	14	7	6	2	6	8	15	26	27	14	8
355	1	2	5	11	21	11	5	5	2	5	7	12	24	21	11	7
400	1	2	4	10	19	10	4	4	2	4	6	11	23	20	10	6
500	--	--	--	--	--	--	--	--	1	3	4	9	17	12	6	4
600	--	--	--	--	--	--	--	--	--	--	--	--	--	--	--	--

RS-N-...-50/100, L1=1950, without central baffle

NW	D _e (dB/oct)															
	P=50								P=100							
	f _m (Hz)								f _m (Hz)							
	63	125	250	500	1000	2000	4000	8000	63	125	250	500	1000	2000	4000	8000
100	9	30	50	50	50	50	50	38	--	--	--	--	--	--	--	--
125	8	26	50	50	50	50	50	33	--	--	--	--	--	--	--	--
160	--	--	--	--	--	--	--	--	8	23	39	50	50	50	41	25
200	--	--	--	--	--	--	--	--	7	19	34	50	50	50	37	21
225	--	--	--	--	--	--	--	--	7	17	32	50	50	50	35	20
250	--	--	--	--	--	--	--	--	6	16	29	48	50	49	33	18
280	--	--	--	--	--	--	--	--	--	--	--	--	--	--	--	--
315	--	--	--	--	--	--	--	--	--	--	--	--	--	--	--	--
355	--	--	--	--	--	--	--	--	--	--	--	--	--	--	--	--
400	--	--	--	--	--	--	--	--	--	--	--	--	--	--	--	--
500	--	--	--	--	--	--	--	--	--	--	--	--	--	--	--	--
630	--	--	--	--	--	--	--	--	--	--	--	--	--	--	--	--

-- = not available

Volumetric flow controller VRAR

Technical data

Volumetric flow range

VRAR-A..., with electric controller

NW (mm)	V	Belimo / Gruner Compact	Belimo VRU-...		Alternative controller brands	
		V_{\min} (1 m/s)	V_{\min} (1 m/s)	V_{\max} (12 m/s)	V_{\min} (2 m/s)	V_{\max} (12 m/s)
100	m³/h	26	26	319	53	319
	l/s	7	7	89	15	89
125	m³/h	42	42	505	84	505
	l/s	11	11	140	23	140
160	m³/h	69	69	836	139	836
	l/s	19	19	232	39	232
200	m³/h	109	109	1317	219	1317
	l/s	30	30	366	61	366
225	m³/h	139	139	1672	279	1672
	l/s	39	39	464	78	464
250	m³/h	172	172	2070	345	2070
	l/s	48	48	575	96	575
280	m³/h	217	217	2603	434	2603
	l/s	60	60	723	121	723
315	m³/h	275	275	3303	550	3303
	l/s	76	76	918	153	918
355	m³/h	350	350	4204	701	4204
	l/s	97	97	1168	195	1168
400	m³/h	445	445	5348	891	5348
	l/s	124	124	1486	248	1486
500	m³/h	698	698	8381	1397	8381
	l/s	194	194	2328	388	2328
630	m³/h	1111	1111	13339	2223	13339
	l/s	309	309	3705	618	3705

VRAR-A..., with pneumatic controller

NW (mm)	V	Sauter RLP	
		V_{\min} (3 m/s)	V_{\max} (12 m/s)
100	m³/h	80	319
	l/s	22	89
125	m³/h	128	505
	l/s	36	140
160	m³/h	209	836
	l/s	58	232
200	m³/h	329	1317
	l/s	91	366
225	m³/h	418	1672
	l/s	116	464
250	m³/h	517	2070
	l/s	144	575
280	m³/h	651	2603
	l/s	181	723
315	m³/h	826	3303
	l/s	229	918
355	m³/h	1051	4204
	l/s	292	1168
400	m³/h	1337	5348
	l/s	371	1486
500	m³/h	2095	8381
	l/s	582	2328
630	m³/h	3335	13339
	l/s	926	3705

Information for parameterisation

Attention, the following specifications are important for the programming of the volumetric flow controllers:

- this table merely specifies the complete measuring range of the controller (volumetric flow range)
- If the customer absolutely wants a calibration curve different from 12 m/s, it must be specified! Once it is approved by the competent department, it can be adjusted correspondingly.
- When the air volume drops below the V_{\min} shown in the chart, the correct functioning of the volumetric flow controller is no longer guaranteed!
- If only one air volume is specified in the order (as V_{\max} value), the volumetric flow controller will be delivered as variable volumetric flow controller. The V_{\min} value will be set to the value specified in the catalogue.
- If only one air volume is specified in the order (as V_{\min} or V_{konstant} value or without value specification), then the volumetric flow controller will be delivered as a constant volumetric flow controller. The volume specified in the order is set to the V_{\min} value, and the V_{\max} value is set to 100%.
- The air volumes can be changed using setting devices specific for the controller make, depending on the calibration curve set ex works.
- The controller of the Gruner make, type 327VM Compact, can be used with a sensor linearized to an air velocity of 1 m/s.
- For the parameter setting of the control components (all controllers), an air density of 1.2 kg/m³ has been taken into account.
- Belimo compact controllers are height-compensated. They are calibrated ex works to the system height in question of the specified installation site.
- If no system height is given in the order, the controllers will be set to the elevation of the delivery address.
- If the customer does not specify whether the "Parallel" or "Master/Slave" operating mode is desired, the controller is set for the parallel operation (Master/Slave mode only upon customer request).
- for alternative controller types, a V-min of 2 m/s or more can be set (pneumatic controller: 3 m/s or more).

Volumetric flow controller VRAR

Static minimum pressure difference
VRAR-A..., with electric controller

NW	v _k (m/s)	V		ΔP _{t min} (Pa)
		(m ³ /h)	[l/s]	
100	2	53	15	20
	6	160	44	25
	9	239	66	50
	12	319	89	70
125	2	84	23	20
	6	252	70	20
	9	379	105	40
	12	505	140	60
160	2	139	39	20
	6	418	116	20
	9	627	174	35
	12	836	232	55
200	2	219	61	15
	6	658	183	20
	9	987	274	25
	12	1316	366	50
225	2	279	78	15
	6	836	232	20
	9	1253	348	25
	12	1671	464	40
250	2	345	96	15
	6	1034	287	15
	9	1552	431	20
	12	2069	575	30
280	2	434	121	15
	6	1301	361	15
	9	1952	542	20
	12	2602	723	25
315	2	550	153	15
	6	1651	459	15
	9	2476	688	20
	12	3301	917	25
355	2	701	195	15
	6	2101	584	15
	9	3151	875	20
	12	4202	1167	25
400	2	891	248	15
	6	2672	742	15
	9	4009	1114	20
	12	5345	1485	25

Volumetric flow controller VRAR

Flow generated noise

Pressure loss 125 Pa and 250 Pa

NW	v _k (m/s)	V (m ³ /h) [l/s]		Δp _r = 125 Pa									Δp _r = 250 Pa								
				L _w [dB/oct]								L _{WA} [dB(A)]	L _w [dB/oct]								L _{WA} [dB(A)]
				f _m (Hz)									f _m (Hz)								
63	125	250	500	1000	2000	4000	8000	63	125	250	500	1000	2000	4000	8000						
100	3	80	22	33	40	37	35	34	33	32	33	39	37	43	43	41	39	38	37	31	46
	6	160	44	41	54	49	45	40	36	35	34	45	43	57	54	50	46	44	43	36	53
	9	239	66	45	55	51	45	40	37	25	35	49	48	63	59	57	51	48	46	39	56
	12	319	89	51	56	55	51	45	40	37	35	52	58	67	63	58	53	49	47	42	59
125	3	126	35	40	42	39	37	36	35	34	36	41	45	45	45	43	41	40	39	39	48
	6	252	70	48	56	51	48	42	38	37	37	47	51	59	56	52	48	46	45	44	55
	9	379	105	52	57	53	47	42	39	37	38	51	56	65	61	59	53	50	48	47	58
	12	505	140	58	58	57	53	47	42	39	38	54	66	69	65	60	55	51	49	56	61
160	3	209	58	43	44	41	39	38	37	36	37	45	48	47	47	45	43	42	41	38	50
	6	418	116	51	58	53	49	44	40	39	38	49	54	61	58	54	50	48	47	42	57
	9	627	174	55	59	55	49	44	41	39	39	53	59	67	63	61	55	52	50	45	60
	12	836	232	61	60	59	55	49	44	41	39	56	69	71	67	62	57	53	51	48	63
200	3	329	91	49	46	43	41	40	39	38	37	45	54	49	49	47	45	44	43	44	52
	6	658	183	57	60	55	51	46	42	41	39	51	60	63	60	56	52	50	49	49	59
	9	987	274	61	61	57	51	46	43	41	40	55	65	69	65	53	67	54	52	52	62
	12	1316	366	67	62	61	57	51	46	43	40	58	75	73	69	64	59	55	53	55	65
225	3	418	116	51	47	44	42	41	40	39	38	46	55	50	50	48	46	45	44	44	53
	6	836	232	59	51	56	52	47	43	42	38	52	61	64	61	58	53	51	50	49	60
	9	1253	348	63	62	58	52	47	44	42	39	56	66	70	66	64	58	55	53	52	63
	12	1671	464	69	63	62	58	52	47	44	40	59	76	74	70	65	60	56	54	44	66
250	3	517	144	53	48	45	43	42	41	40	39	47	57	51	51	49	47	46	45	45	54
	6	1034	287	61	62	57	53	48	44	43	40	53	63	65	62	58	54	52	51	50	61
	9	1552	431	65	63	59	53	48	45	43	41	57	68	71	67	65	59	56	54	53	64
	12	2069	575	71	64	63	59	53	48	45	41	60	78	75	71	66	61	57	55	56	67
280	3	651	181	54	49	46	44	43	42	41	37	47	57	52	52	50	48	47	46	46	55
	6	1301	361	62	63	58	54	49	45	44	41	57	64	66	63	59	55	53	52	51	62
	9	1952	542	66	64	60	54	49	46	44	41	58	69	72	68	66	60	57	55	54	65
	12	2602	723	72	65	64	60	54	49	46	42	61	79	76	72	67	62	58	56	57	68
315	3	825	229	55	50	47	45	44	43	42	39	49	57	47	42	44	45	47	40	45	56
	6	1651	459	63	64	59	55	50	46	45	41	55	63	61	53	53	52	53	46	50	63
	9	2476	688	67	65	61	55	50	47	45	42	49	68	67	64	61	58	56	54	53	66
	12	3301	917	73	66	65	61	55	50	47	42	62	78	71	62	60	58	57	56	56	69
355	3	1050	292	56	51	48	46	45	44	43	41	50	61	54	54	52	50	49	48	48	57
	6	2101	584	64	65	60	56	51	47	46	41	56	67	58	54	51	57	55	54	53	64
	9	3151	875	68	66	62	56	51	47	46	42	60	72	74	70	68	62	59	57	56	67
	12	4202	1167	74	67	66	62	56	51	48	43	63	82	78	74	69	64	60	58	59	70
400	3	1336	371	57	52	49	47	46	45	44	42	51	64	55	55	53	51	50	49	49	58
	6	2672	742	65	66	61	57	52	48	47	43	57	70	69	66	62	58	56	55	54	65
	9	4009	1114	69	67	63	57	52	49	47	44	61	75	75	71	69	63	60	58	57	68
	12	5345	1485	75	68	67	63	57	52	49	44	64	85	79	75	70	65	61	59	60	71
500	3	2094	582	59	54	51	49	48	47	46	44	53	64	57	57	55	53	52	51	51	60
	6	4188	1163	67	68	63	59	54	50	49	44	59	70	71	68	64	60	58	57	56	67
	9	6282	1745	71	69	65	59	54	51	49	45	63	75	77	73	71	65	62	60	59	70
	12	8377	2327	77	70	69	65	59	54	51	46	66	85	81	77	72	67	63	61	62	73
630	3	3333	926	61	56	53	51	50	49	48	46	55	66	59	59	57	55	54	53	53	62
	6	6666	1852	69	70	65	61	56	52	51	47	61	72	73	70	66	62	60	59	58	69
	9	9999	2778	73	71	67	61	56	53	51	48	65	77	79	75	73	67	64	62	61	72
	12	13332	3703	79	72	71	67	61	56	53	48	68	87	83	79	74	69	65	63	64	75

Volumetric flow controller VRAR

Flow generated noise
Pressure loss 500 Pa and 1000 Pa

NW	v _K (m/s)	V (m ³ /h) [l/s]		Δp _t = 500 Pa									L _{WA} [dB(A)]	Δp _t = 1000 Pa									L _{WA} [dB(A)]
				L _W [dB/oct]										L _W [dB/oct]									
				f _m (Hz)										f _m (Hz)									
63	125	250	500	1000	2000	4000	8000					63	125	250	500	1000	2000	4000	8000				
100	3	80	22	41	48	47	46	45	44	41	41	52	58	55	52	52	53	52	50	50	57		
	6	160	44	45	61	58	56	63	52	47	46	58	62	61	61	60	59	58	56	57	64		
	9	239	66	53	69	66	61	57	54	51	50	62	69	69	68	65	64	64	59	59	70		
	12	319	89	56	71	67	63	59	56	54	52	65	73	70	71	70	68	67	63	63	76		
125	3	126	35	49	50	49	48	47	46	43	42	54	60	57	54	54	55	54	52	51	59		
	6	252	70	53	63	60	58	55	54	49	47	60	64	63	63	62	61	60	58	58	66		
	9	379	105	61	71	68	63	59	56	53	51	64	71	71	70	67	66	66	61	60	72		
	12	505	140	64	73	69	65	61	58	56	53	67	75	74	73	72	70	69	65	64	78		
160	3	209	58	55	52	51	50	49	48	45	46	56	62	59	56	56	57	56	54	53	61		
	6	418	116	59	65	62	60	57	56	51	51	62	66	65	65	64	63	62	60	60	68		
	9	627	174	67	73	70	65	61	58	55	55	66	73	73	72	69	68	68	63	62	74		
	12	836	232	70	75	71	67	63	60	58	57	69	77	76	75	74	72	71	67	66	80		
200	3	329	91	60	54	53	52	51	50	47	47	58	64	61	58	58	59	58	56	55	63		
	6	658	183	64	67	64	62	49	48	43	42	64	68	67	67	66	65	64	62	62	70		
	9	987	274	72	75	72	67	63	60	57	56	68	75	75	74	71	70	70	65	64	76		
	12	1316	366	75	77	73	69	65	62	60	59	71	79	78	77	76	74	73	69	68	82		
225	3	418	116	61	55	54	53	52	51	48	48	59	65	62	59	59	60	59	57	56	64		
	6	836	232	65	68	65	63	60	59	54	53	65	69	68	68	67	66	65	63	63	71		
	9	1253	348	73	76	73	68	64	61	58	57	69	76	76	75	72	71	71	66	65	77		
	12	1671	464	76	78	74	70	66	63	61	59	72	80	79	78	77	75	74	70	69	83		
250	3	517	144	63	56	55	54	53	52	49	49	60	66	63	60	60	61	60	58	57	65		
	6	1034	287	67	69	66	64	61	60	55	54	66	70	69	69	68	67	66	64	64	72		
	9	1552	431	75	77	74	69	65	62	59	58	70	77	77	76	73	72	72	67	66	78		
	12	2069	575	78	79	75	71	67	64	62	60	73	81	80	79	78	76	75	71	70	84		
280	3	651	181	64	57	56	55	54	53	50	50	61	67	64	61	61	62	61	59	58	66		
	6	1301	361	68	70	67	65	62	61	56	55	67	71	70	70	69	68	67	65	65	73		
	9	1952	542	76	78	75	70	66	63	60	59	71	78	78	76	74	73	73	68	67	79		
	12	2602	723	79	80	76	72	68	65	63	61	74	82	81	79	79	77	76	72	71	85		
315	3	825	229	66	58	57	56	55	54	51	51	62	68	65	62	62	63	62	60	59	67		
	6	1651	459	70	71	68	66	63	62	57	56	68	72	71	71	70	69	68	66	66	74		
	9	2476	688	78	79	76	71	67	64	61	60	72	79	79	78	75	74	74	69	68	80		
	12	3301	917	81	81	77	73	69	66	64	62	75	83	82	81	80	78	77	73	72	86		
355	3	1050	292	67	59	58	57	56	55	52	52	63	69	66	63	63	64	63	61	60	68		
	6	2101	584	71	72	69	67	64	63	58	57	69	73	72	72	71	70	69	67	67	75		
	9	3151	875	79	80	77	72	68	65	62	61	73	80	80	79	76	75	75	70	69	81		
	12	4202	1167	82	82	78	74	70	67	65	63	78	84	83	82	81	79	78	74	73	87		
400	3	1336	371	59	60	59	58	57	56	53	53	64	70	67	64	64	65	64	62	61	69		
	6	2672	742	73	73	70	68	65	64	59	58	70	74	73	73	72	71	70	58	58	76		
	9	4009	1114	81	81	78	73	69	66	63	62	74	81	81	80	77	76	76	71	71	82		
	12	5345	1485	84	83	79	75	71	68	66	64	77	85	84	83	82	80	79	75	75	88		
500	3	2094	582	70	62	61	60	59	58	55	55	66	72	69	66	66	67	66	64	63	71		
	6	4188	1163	74	75	72	70	67	66	61	60	72	76	75	75	74	73	72	70	70	78		
	9	6282	1745	82	83	80	75	71	68	65	64	76	83	83	82	79	78	78	73	72	84		
	12	8377	2327	85	85	81	77	73	70	68	66	79	87	86	85	84	82	81	77	76	90		
630	3	3333	926	72	64	63	62	61	60	57	57	68	74	71	68	68	69	68	66	65	73		
	6	6666	1852	76	77	74	72	69	68	63	62	74	78	77	77	76	75	74	72	72	80		
	9	9999	2778	84	85	82	77	73	70	67	66	78	85	85	84	81	80	80	75	74	86		
	12	13332	3703	87	87	83	79	75	72	70	68	81	89	88	87	86	84	83	79	78	92		

Volumetric flow controller VRAR

Radiated noise

Pressure loss 125 Pa and 500 Pa

NW	v _k (m/s)	V (m ³ /h) [l/s]		Δp _t = 125 Pa									L _{WA} [dB(A)]	Δp _t = 250 Pa									L _{WA} [dB(A)]
				L _W [dB/oct]										L _W [dB/oct]									
				f _m (Hz)										f _m (Hz)									
63	125	250	500	1000	2000	4000	8000					63	125	250	500	1000	2000	4000	8000				
100	3	80	22	8	22	21	22	18	20	21	22	24	19	25	27	28	23	25	26	20	31		
	6	160	44	23	36	33	32	24	23	24	23	31	25	39	38	37	30	31	32	25	38		
	9	239	66	27	37	35	32	24	24	24	23	34	30	45	43	44	35	35	35	28	42		
	12	319	89	33	38	39	38	29	27	26	24	37	40	49	47	45	37	36	36	31	44		
125	3	126	35	22	24	23	20	20	22	25	27	26	27	27	29	26	25	27	30	30	33		
	6	252	70	30	38	35	30	26	25	28	28	33	33	41	40	35	32	33	36	35	40		
	9	379	105	34	39	37	30	26	26	28	29	36	37	47	45	42	37	37	39	38	44		
	12	505	140	40	40	41	36	31	29	30	29	39	48	51	49	43	39	38	40	38	46		
160	3	209	58	25	26	27	21	23	24	27	28	28	30	29	33	27	28	29	32	30	35		
	6	418	116	33	40	39	31	29	27	30	29	35	36	43	44	36	35	35	38	33	42		
	9	627	174	37	41	41	31	29	28	30	30	38	41	49	49	43	40	39	41	36	46		
	12	836	232	43	42	45	37	34	31	32	32	41	51	53	53	44	42	40	42	39	48		
200	3	329	91	36	33	30	24	25	28	30	30	32	41	36	36	30	30	33	35	36	39		
	6	658	183	45	47	42	34	31	31	33	31	38	47	50	47	39	37	39	41	41	46		
	9	987	274	48	48	44	34	31	32	33	32	42	52	56	52	46	42	43	44	44	49		
	12	1316	366	54	49	48	40	36	35	35	32	45	62	60	56	57	44	44	45	47	52		
225	3	418	116	41	37	31	27	30	30	31	30	35	45	40	37	33	35	35	36	36	42		
	6	836	232	50	51	43	37	36	33	34	30	41	51	54	48	42	42	41	42	41	49		
	9	1253	348	53	52	45	37	36	34	34	31	45	56	60	53	49	47	45	45	44	52		
	12	1671	464	60	53	49	43	41	37	36	32	48	66	64	57	50	49	46	46	47	55		
250	3	517	144	45	40	30	27	28	30	32	31	35	49	43	36	33	33	35	37	37	42		
	6	1034	287	54	54	42	37	34	33	35	32	41	55	57	47	42	40	41	43	42	49		
	9	1552	431	57	55	44	37	34	34	35	33	45	60	63	52	49	45	45	46	45	52		
	12	2069	575	63	56	48	43	39	37	37	33	48	70	67	56	50	47	46	47	48	55		
280	3	651	181	46	41	33	31	33	32	32	29	37	50	44	39	37	38	37	37	37	44		
	6	1301	361	55	55	45	41	39	35	35	32	43	56	58	50	46	45	43	43	42	51		
	9	1952	542	58	56	47	41	39	36	35	32	47	61	64	55	53	50	47	46	45	54		
	12	2602	723	64	57	51	47	44	39	37	33	50	71	68	59	54	52	48	47	48	57		
315	3	825	229	47	42	32	29	30	33	34	31	37	45	32	27	28	31	37	32	37	44		
	6	1651	459	55	56	44	39	36	36	37	33	43	48	46	38	37	38	43	38	42	51		
	9	2476	688	59	57	46	39	36	37	37	34	47	53	52	49	45	44	46	46	45	54		
	12	3301	917	65	58	50	45	41	40	39	34	50	63	56	47	44	44	47	48	48	57		
355	3	1050	292	48	43	35	31	35	38	36	34	40	53	46	41	37	40	43	41	41	47		
	6	2101	584	56	57	47	41	41	41	39	34	46	59	60	52	46	47	49	47	46	54		
	9	3151	875	60	58	49	41	41	42	39	35	50	64	66	57	53	52	53	50	49	57		
	12	4202	1167	66	59	53	47	46	45	41	36	53	74	70	61	54	54	54	51	50	60		
400	3	1336	371	47	42	37	33	36	33	37	35	40	54	45	43	39	41	38	42	42	47		
	6	2672	742	55	56	49	43	42	36	40	36	46	60	59	54	48	48	44	48	47	54		
	9	4009	1114	59	57	51	43	42	37	40	37	50	65	65	59	55	53	48	51	50	57		
	12	5345	1485	65	58	55	49	47	40	52	37	53	75	69	63	56	55	49	52	53	60		
500	3	2094	582	52	47	42	41	43	44	44	42	47	57	50	48	47	48	49	49	49	54		
	6	4188	1163	60	61	54	51	49	47	47	42	53	63	64	59	56	55	55	55	54	61		
	9	6282	1745	64	62	56	51	49	48	47	43	57	68	70	64	63	60	59	58	57	64		
	12	8377	2327	70	63	60	57	54	51	49	44	60	78	74	68	64	62	60	59	60	67		
630	3	3333	926	55	50	49	46	46	46	46	44	51	60	53	55	52	51	51	51	51	58		
	6	6666	1852	63	64	61	56	52	49	49	45	57	66	67	66	61	58	57	57	56	65		
	9	9999	2778	67	65	63	56	52	50	49	46	61	71	73	71	68	63	61	60	59	68		
	12	13332	3703	73	66	67	62	57	53	51	46	64	81	77	75	69	65	62	61	62	71		

Volumetric flow controller VRAR

Radiated noise

Pressure loss 500 Pa and 1000 Pa

NW	v _K (m/s)	V (m ³ /h) [l/s]		Δp _t = 500 Pa										Δp _t = 1000 Pa											
				L _W [dB/oct]										L _{WA} [dB(A)]	L _W [dB/oct]										L _{WA} [dB(A)]
				f _m (Hz)											f _m (Hz)										
				63	125	250	500	1000	2000	4000	8000	L _{WA} [dB(A)]	63	125	250	500	1000	2000	4000	8000	L _{WA} [dB(A)]				
100	3	80	22	23	30	31	33	29	31	30	30	37	40	37	36	39	37	39	39	39	42				
	6	160	44	27	43	42	43	37	39	36	35	43	44	43	45	47	43	45	45	46	49				
	9	239	66	35	51	50	48	41	41	40	39	47	51	51	52	53	48	51	48	49	55				
	12	319	89	38	53	51	50	43	43	43	41	50	55	54	55	58	52	56	52	53	61				
125	3	126	35	31	32	33	31	31	33	34	33	39	42	39	38	37	39	41	43	42	44				
	6	252	70	35	45	44	41	39	41	40	38	45	46	45	47	45	45	47	49	49	51				
	9	379	105	43	53	52	46	43	43	44	42	49	53	53	54	51	50	53	52	52	57				
	12	505	140	46	55	53	48	45	45	47	44	52	57	56	57	56	54	58	56	56	63				
160	3	209	58	37	34	37	32	34	35	36	37	41	47	44	42	39	41	44	46	45	47				
	6	418	116	41	47	48	42	42	43	42	42	47	51	50	51	47	47	50	52	52	54				
	9	627	174	49	55	56	47	46	45	46	46	51	58	58	58	53	52	56	55	55	60				
	12	836	232	52	57	57	49	48	47	49	48	54	62	61	61	58	56	61	59	59	66				
200	3	329	91	47	41	40	35	36	39	39	39	45	51	48	45	41	44	47	48	47	50				
	6	658	183	51	54	51	45	44	47	45	44	51	55	54	54	49	50	53	54	54	57				
	9	987	274	59	62	59	50	48	49	49	48	55	62	62	61	55	55	59	77	57	63				
	12	1316	366	62	64	60	52	50	51	52	51	58	66	65	64	60	59	64	61	61	69				
225	3	418	116	51	45	41	38	41	41	40	40	48	55	52	46	44	49	49	49	48	53				
	6	836	232	55	58	52	48	49	49	46	45	54	49	58	55	52	55	55	55	55	60				
	9	1253	348	65	66	60	53	53	51	50	49	58	66	66	62	58	60	61	58	58	66				
	12	1671	464	66	68	61	55	55	53	53	51	61	70	69	65	63	64	66	62	62	72				
250	3	517	144	55	48	40	38	39	41	41	41	48	58	55	45	44	47	49	50	49	53				
	6	1034	287	59	61	51	48	47	49	47	46	54	62	61	54	52	53	55	56	56	60				
	9	1552	431	67	69	59	53	51	51	51	50	58	69	69	61	58	58	61	59	59	66				
	12	2069	575	70	71	60	55	53	53	54	52	61	73	72	64	63	62	66	63	63	72				
280	3	651	181	56	49	43	42	44	43	41	41	50	59	56	48	48	52	51	50	49	55				
	6	1301	361	60	62	54	52	52	51	47	46	56	63	62	57	56	58	57	56	56	62				
	9	1952	542	68	70	62	57	56	53	51	50	60	70	70	64	62	63	63	59	59	68				
	12	2602	723	71	72	63	59	58	55	54	52	63	74	73	67	67	67	68	63	63	74				
315	3	825	229	58	50	42	40	41	44	43	43	50	60	57	47	46	49	52	52	51	55				
	6	1651	459	62	63	53	50	49	52	49	48	56	64	63	56	54	55	58	58	58	62				
	9	2476	688	70	71	61	55	53	54	53	52	60	71	71	63	60	60	64	61	61	68				
	12	3301	917	73	73	62	57	55	56	56	54	63	75	74	66	65	64	69	65	65	74				
355	3	1050	292	59	51	45	42	46	49	45	45	53	61	58	50	48	54	57	54	53	58				
	6	2101	584	63	64	56	52	54	57	51	50	59	65	64	59	56	60	63	60	60	65				
	9	3151	875	71	72	64	57	58	59	55	54	63	72	72	66	62	60	69	63	63	71				
	12	4202	1167	74	74	65	59	60	61	58	56	66	76	75	69	67	64	74	67	67	77				
400	3	1336	371	59	50	47	44	47	44	46	46	53	62	57	52	50	55	52	55	54	58				
	6	2672	742	63	63	58	54	55	52	52	51	59	66	63	61	58	61	58	61	61	65				
	9	4009	1114	71	71	66	59	59	54	56	55	63	73	72	68	64	66	64	64	64	71				
	12	5345	1485	74	73	67	61	61	56	59	57	66	77	75	71	69	70	69	68	68	77				
500	3	2094	582	63	55	52	52	54	55	53	53	60	65	62	57	58	62	63	62	61	65				
	6	4188	1163	67	68	63	62	62	63	59	58	66	69	68	66	66	68	69	68	68	72				
	9	6282	1745	75	76	71	67	66	65	63	62	70	76	76	73	72	73	75	71	71	78				
	12	8377	2327	78	78	72	69	68	67	66	64	73	80	79	76	77	77	80	75	75	84				
630	3	3333	926	66	58	59	57	57	57	55	55	64	68	65	64	63	65	65	64	63	69				
	6	6666	1852	70	71	70	67	65	65	61	60	70	72	71	73	71	71	71	70	70	76				
	9	9999	2778	78	79	78	72	69	67	65	64	74	79	79	80	77	76	77	73	73	82				
	12	13332	3703	81	81	79	74	71	69	68	66	77	83	82	83	82	80	82	77	77	88				

Volumetric flow controller VRAR

Flow generated noise

VRAR...-RS-N, with duct silencer L1=950

Pressure loss 125 Pa and 250 Pa

NW	v _k (m/s)	V (m ³ /h) [l/s]		Δp _t = 125 Pa									Δp _t = 250 Pa								
				L _w [dB/oct]								L _{WA} [dB(A)]	L _w [dB/oct]								L _{WA} [dB(A)]
				63	125	250	500	1000	2000	4000	8000		63	125	250	500	1000	2000	4000	8000	
100	3	80	22	28	28	<15	<15	<15	<15	<15	<15	15	32	31	20	<15	<15	<15	<15	<15	18
	6	160	44	36	42	26	<15	<15	<15	<15	<15	26	38	45	31	<15	<15	<15	<15	15	30
	9	239	66	40	43	28	<15	<15	<15	<15	<15	28	43	51	36	21	<15	<15	<15	18	35
	12	319	89	46	44	32	15	<15	<15	<15	<15	30	53	55	40	22	<15	<15	<15	21	40
125	3	126	35	36	31	18	<15	<15	<15	<15	17	19	41	34	24	<15	<15	<15	<15	20	23
	6	252	70	44	45	30	<15	<15	<15	<15	18	30	47	48	35	19	<15	<15	<15	25	34
	9	379	105	48	46	32	<15	<15	<15	<15	19	31	52	54	40	26	<15	<15	16	28	39
	12	505	140	54	47	36	20	<15	<15	<15	19	34	62	58	44	27	<15	<15	17	27	43
160	3	209	58	39	34	23	<15	<15	<15	<15	21	23	44	37	29	17	<15	<15	15	21	26
	6	418	116	47	48	35	21	<15	<15	<15	22	33	50	51	40	26	<15	<15	21	26	37
	9	627	174	51	50	41	27	<15	<15	<15	23	35	55	57	45	33	<15	<15	24	29	43
	12	836	232	57	50	41	27	<15	<15	15	23	37	65	61	49	34	16	<15	25	32	47
200	3	329	91	46	37	28	17	<15	<15	16	25	28	51	40	34	23	<15	<15	21	31	33
	6	658	183	54	51	40	27	<15	<15	19	26	37	57	54	45	32	17	<15	27	36	42
	9	987	274	58	52	42	27	<15	<15	19	27	39	62	60	50	39	22	<15	30	39	47
	12	1316	366	64	53	46	33	16	<15	21	27	42	72	64	54	40	24	<15	31	42	52
225	3	418	116	48	39	30	20	<15	<15	18	26	30	52	42	36	26	<15	<15	23	32	35
	6	836	232	56	53	42	30	<15	<15	21	26	39	58	56	47	35	20	<15	29	37	44
	9	1253	348	60	54	44	30	<15	<15	21	27	41	63	62	52	42	25	17	32	40	49
	12	1671	464	66	55	48	36	19	<15	23	28	44	73	66	56	43	27	18	33	43	53
250	3	517	144	50	41	32	23	<15	<15	20	28	32	54	44	38	29	16	<15	25	34	37
	6	1034	287	58	55	44	33	17	<15	23	29	41	60	58	49	38	23	17	31	39	46
	9	1552	431	62	56	46	33	17	<15	23	30	43	65	64	54	45	28	21	34	42	51
	12	2069	575	68	57	50	39	22	<15	25	30	47	75	68	58	46	30	22	35	45	55
280	3	651	181	51	43	35	25	<15	<15	22	28	33	55	46	51	31	18	<15	27	36	39
	6	1301	361	59	57	47	35	19	<15	25	31	44	61	60	52	40	25	19	33	41	48
	9	1952	542	63	58	49	35	16	<15	25	31	45	66	66	57	47	30	23	36	44	53
	12	2602	723	69	59	53	41	24	15	27	32	49	76	70	61	48	32	24	37	47	58
315	3	825	229	52	44	37	28	17	<15	25	30	35	54	51	32	27	18	16	23	36	37
	6	1651	459	60	58	49	38	23	15	28	32	45	60	55	43	36	25	22	29	41	44
	9	2476	688	64	59	51	38	23	16	28	33	47	65	61	54	44	31	25	37	44	50
	12	3301	917	70	60	55	44	28	19	30	33	50	75	67	52	43	31	26	39	47	54
355	3	1050	292	53	46	39	31	21	16	27	33	37	58	49	45	37	26	21	32	40	43
	6	2101	584	61	60	51	51	27	19	30	33	47	64	63	56	46	33	27	38	45	52
	9	3151	875	65	61	53	41	27	20	30	34	49	69	69	61	53	38	31	41	48	57
	12	4202	1167	71	62	57	47	32	23	32	35	52	79	73	65	54	40	32	42	51	61
400	3	1336	371	54	47	40	33	23	18	29	35	39	61	50	46	39	28	23	34	42	45
	6	2672	742	62	61	52	43	29	21	32	36	48	67	64	57	48	35	29	40	47	53
	9	4009	1114	62	61	52	43	29	21	32	36	50	72	70	62	55	40	33	43	50	69
	12	5345	1485	66	62	54	43	29	22	32	37	53	82	74	66	56	42	34	44	53	63
500	3	2094	582	72	63	58	49	34	25	34	37	43	61	53	50	44	35	31	39	45	49
	6	4188	1163	56	50	44	38	30	26	34	38	52	67	67	61	53	42	37	45	50	57
	9	6282	1745	64	64	56	48	36	29	37	38	53	72	73	66	60	47	41	48	53	63
	12	8377	2327	68	65	58	48	36	30	37	39	57	82	77	70	61	49	42	49	56	66
630	3	3333	926	74	66	62	54	41	33	39	40	47	65	56	54	48	41	37	44	48	53
	6	6666	1852	60	53	48	42	36	32	39	41	56	71	70	65	57	48	43	50	53	61
	9	9999	2778	72	68	62	52	42	36	42	43	57	76	76	70	64	53	47	53	56	66
	12	13332	3703	78	69	66	58	47	39	44	43	61	86	80	74	65	55	48	54	59	70

Volumetric flow controller VRAR

Flow generated noise

VRAR-...-RS-N, with duct silencer L1=950

Pressure loss 500 Pa and 1000 Pa

NW	v _K (m/s)	V (m ³ /h) [l/s]		Δp _t = 500 Pa										Δp _t = 1000 Pa											
				L _W [dB/oct]										L _{WA} [dB(A)]	L _W [dB/oct]										L _{WA} [dB(A)]
				63	125	250	500	1000	2000	4000	8000	63	125		250	500	1000	2000	4000	8000					
100	3	80	22	36	36	24	<15	<15	<15	<15	20	23	53	43	29	16	<15	<15	16	29	32				
	6	160	44	40	49	35	20	<15	<15	<15	25	34	57	49	38	24	<15	<15	22	36	39				
	9	239	66	48	57	43	25	<15	<15	17	29	42	64	57	45	29	<15	<15	25	38	44				
	12	319	89	51	59	44	27	<15	<15	20	31	44	68	58	48	34	18	17	29	42	47				
125	3	126	35	45	39	28	15	<15	<15	<15	23	27	56	46	33	21	<15	<15	20	32	35				
	6	252	70	49	52	39	25	<15	<15	17	28	37	60	52	42	29	<15	<15	26	39	42				
	9	379	105	57	60	47	30	<15	<15	21	32	45	67	60	49	34	16	16	29	41	48				
	12	505	140	60	62	48	32	<15	<15	24	34	47	71	63	52	39	20	19	33	45	51				
160	3	209	58	51	42	33	22	<15	<15	19	30	33	58	49	38	28	16	<15	28	37	40				
	6	418	116	55	55	44	32	16	<15	25	35	42	62	55	47	36	22	<15	34	44	46				
	9	627	174	63	63	52	37	20	<15	29	39	49	69	63	54	41	27	20	37	46	51				
	12	836	232	66	65	53	39	22	<15	32	41	51	73	66	57	46	31	23	41	50	55				
200	3	329	91	57	45	38	28	16	<15	25	34	37	61	52	43	34	24	17	34	42	44				
	6	658	183	61	58	49	38	24	17	31	39	46	65	48	52	42	30	23	40	49	51				
	9	987	274	69	66	57	43	28	19	35	43	53	72	66	59	47	35	29	43	51	56				
	12	1316	366	72	68	58	45	30	21	38	46	55	76	69	62	52	39	32	47	55	59				
225	3	418	116	58	47	40	31	19	<15	27	36	39	62	54	45	37	27	21	26	44	46				
	6	836	232	62	60	51	41	27	21	33	41	48	66	60	54	45	33	27	42	51	53				
	9	1253	348	70	68	59	46	31	23	37	45	55	73	68	64	50	38	33	45	53	58				
	12	1671	464	73	70	60	48	33	25	40	47	57	77	71	64	55	42	36	49	57	61				
250	3	517	144	60	49	42	34	22	17	29	38	41	63	56	47	40	30	25	38	46	48				
	6	1034	287	64	62	53	44	30	25	35	43	50	67	62	56	48	36	31	44	53	55				
	9	1552	431	72	70	61	49	34	27	39	47	57	74	70	63	53	41	37	47	55	60				
	12	2069	575	75	72	62	51	36	29	42	49	59	78	73	66	58	45	40	51	59	64				
280	3	651	181	61	51	45	36	24	19	31	40	43	64	58	50	42	32	27	40	48	50				
	6	1301	361	65	64	56	46	32	27	37	45	52	68	64	59	50	38	33	46	55	57				
	9	1952	542	73	72	64	51	36	29	41	49	59	75	72	65	55	43	39	49	57	62				
	12	2602	723	76	74	65	53	38	31	44	51	61	79	75	68	60	47	42	53	61	65				
315	3	825	229	63	52	57	39	28	23	34	42	45	65	59	52	45	36	31	43	50	52				
	6	1651	459	67	52	47	39	28	23	34	42	54	69	65	61	53	42	37	49	57	59				
	9	2476	688	75	73	66	54	40	33	44	51	61	76	73	68	58	47	43	52	59	64				
	12	3301	917	78	75	67	56	42	35	47	53	63	80	76	71	63	51	46	56	63	68				
355	3	1050	292	64	54	49	42	32	27	36	44	48	66	61	54	48	40	35	45	52	54				
	6	2101	584	68	67	60	52	40	35	42	49	56	70	67	63	56	46	41	51	59	62				
	9	3151	875	76	75	68	57	44	37	46	53	63	77	75	70	61	51	47	54	61	66				
	12	4202	1167	79	77	69	59	46	39	49	55	65	81	78	73	66	55	50	58	65	70				
400	3	1336	371	56	55	50	44	34	29	38	46	49	67	62	55	50	42	37	47	54	56				
	6	2672	742	70	68	61	54	42	37	44	51	58	71	68	64	58	48	43	53	61	63				
	9	4009	1114	78	76	69	59	46	39	48	55	65	78	76	71	63	53	49	56	64	68				
	12	5345	1485	81	78	70	61	48	41	51	57	66	82	79	74	68	57	52	60	68	72				
500	3	2094	582	67	58	54	49	41	37	43	49	53	69	65	59	55	49	45	52	57	60				
	6	4188	1163	71	71	65	59	49	45	49	54	62	73	71	68	63	55	51	58	64	67				
	9	6282	1745	79	79	73	64	53	47	53	58	68	80	79	75	68	60	57	61	66	72				
	12	8377	2327	82	81	74	66	55	49	56	60	70	84	82	78	73	64	60	65	70	76				
630	3	3333	926	71	61	58	53	47	43	48	52	57	73	68	63	59	55	51	57	60	64				
	6	6666	1852	75	74	69	63	55	51	54	57	66	77	74	72	67	61	57	63	67	71				
	9	9999	2778	83	82	77	68	59	53	58	61	72	84	82	79	72	66	63	66	69	76				
	12	13332	3703	86	84	78	70	61	55	61	63	74	88	85	82	77	70	66	70	73	80				

Volumetric flow controller VRAR

Flow generated noise

VRAR-...-RS-N, with duct silencer L1=1450

Pressure loss 125 Pa and 250 Pa

NW	v _k (m/s)	V (m ³ /h) [l/s]		Δp _t = 125 Pa									Δp _t = 250 Pa								
				L _w [dB/oct]								L _{WA} [dB(A)]	L _w [dB/oct]								L _{WA} [dB(A)]
				f _m (Hz)									f _m (Hz)								
63	125	250	500	1000	2000	4000	8000	63	125	250	500	1000	2000	4000	8000						
100	3	80	22	25	18	<15	<15	<15	<15	<15	<15	7	29	21	<15	<15	<15	<15	<15	<15	8
	6	160	44	33	32	<15	<15	<15	<15	<15	<15	16	35	35	<15	<15	<15	<15	<15	<15	19
	9	239	66	37	33	<15	<15	<15	<15	<15	<15	18	40	41	15	<15	<15	<15	<15	<15	25
	12	319	89	43	34	<15	<15	<15	<15	<15	<15	20	50	45	19	<15	<15	<15	<15	<15	30
125	3	126	35	33	22	<15	<15	<15	<15	<15	<15	13	38	25	<15	<15	<15	<15	<15	<15	16
	6	252	70	41	36	<15	<15	<15	<15	<15	<15	21	44	39	17	<15	<15	<15	<15	19	36
	9	379	105	45	37	<15	<15	<15	<15	<15	<15	23	49	45	22	<15	<15	<15	<15	22	30
	12	505	140	51	38	18	<15	<15	<15	<15	<15	27	59	49	26	<15	<15	<15	<15	21	36
160	3	209	58	37	27	<15	<15	<15	<15	<15	19	20	42	30	17	<15	<15	<15	<15	19	22
	6	418	116	45	41	23	<15	<15	<15	<15	20	27	48	44	28	<15	<15	<15	17	24	30
	9	627	174	49	42	25	<15	<15	<15	<15	21	28	53	50	33	<15	<15	<15	20	27	35
	12	836	232	55	43	29	<15	<15	<15	<15	21	32	63	54	37	15	<15	<15	21	30	41
200	3	329	91	44	32	17	<15	<15	<15	<15	22	24	49	35	23	<15	<15	<15	15	28	29
	6	658	183	52	46	29	<15	<15	<15	<15	23	32	55	49	34	<15	<15	<15	21	33	37
	9	987	274	56	47	31	<15	<15	<15	<15	24	34	60	55	39	21	<15	<15	24	36	41
	12	1316	366	62	48	35	15	<15	<15	15	24	38	70	59	43	22	<15	<15	25	39	47
225	3	418	116	46	34	20	<15	<15	<15	<15	23	25	50	37	26	<15	<15	<15	18	29	30
	6	836	232	54	48	32	<15	<15	<15	16	23	34	56	51	37	19	<15	<15	24	34	38
	9	1253	348	58	49	34	<15	<15	<15	16	24	36	61	57	42	26	<15	<15	27	37	43
	12	1671	464	64	50	38	20	<15	<15	18	25	40	71	61	46	27	<15	<15	28	40	49
250	3	517	144	49	36	23	<15	<15	<15	15	25	28	53	39	29	<15	<15	<15	20	31	33
	6	1034	287	57	50	35	17	<15	<15	18	26	36	59	53	40	22	<15	<15	26	36	41
	9	1552	431	61	51	37	17	<15	<15	18	27	38	64	59	45	29	<15	<15	29	39	45
	12	2069	575	67	52	41	23	<15	<15	20	27	43	74	63	49	30	15	<15	30	42	51
280	3	651	181	50	38	26	<15	<15	<15	19	26	29	54	41	32	17	<15	<15	24	34	35
	6	1301	361	58	52	38	21	<15	<15	22	29	38	60	55	43	26	<15	16	30	39	43
	9	1952	542	62	53	40	21	<15	<15	22	29	40	65	61	48	33	18	20	33	42	48
	12	2602	723	68	54	44	27	<15	<15	24	30	44	75	65	52	34	20	21	34	45	53
315	3	825	229	52	40	29	<15	<15	<15	21	28	31	54	37	24	<15	<15	<15	19	34	35
	6	1651	459	60	54	41	24	<15	<15	24	30	40	60	51	35	22	<15	19	25	39	41
	9	2476	688	64	55	43	24	<15	<15	24	31	42	65	57	46	30	19	22	33	42	46
	12	3301	917	70	56	47	30	16	16	26	31	46	75	61	44	29	19	23	35	45	51
355	3	1050	292	53	42	31	18	<15	<15	23	31	34	58	45	37	24	<15	18	28	38	39
	6	2101	584	61	56	43	28	15	16	26	31	42	64	59	48	33	21	24	34	43	47
	9	3151	875	65	57	45	28	15	17	26	32	44	69	65	53	40	26	28	37	46	52
	12	4202	1167	71	58	49	34	20	20	28	33	48	79	69	57	41	28	29	38	49	57
400	3	1336	371	54	44	34	22	<15	16	26	33	36	61	47	40	28	18	21	31	40	42
	6	2672	742	62	58	46	32	19	19	29	34	44	67	61	51	37	25	27	38	45	50
	9	4009	1114	66	59	48	32	19	20	29	35	46	72	67	56	44	30	31	40	48	54
	12	5345	1485	72	60	52	38	24	23	31	35	50	82	71	60	45	32	32	41	51	60
500	3	2094	582	56	47	39	30	23	23	33	36	40	61	50	45	36	28	28	38	43	46
	6	4188	1163	64	61	51	40	29	26	36	36	48	67	64	56	45	35	34	44	48	54
	9	6282	1745	68	62	53	40	29	27	36	37	50	72	70	61	52	40	38	47	51	58
	12	8377	2327	74	63	57	46	34	30	38	38	53	82	74	65	53	42	39	48	54	62
630	3	3333	926	59	52	44	34	29	30	36	41	44	64	55	50	40	34	35	41	48	50
	6	6666	1852	67	66	46	44	35	33	39	42	53	70	69	61	49	41	41	47	53	58
	9	9999	2778	71	67	58	44	35	34	39	43	57	75	75	66	56	46	45	50	56	63
	12	13332	3703	77	68	62	50	40	37	41	43	58	85	79	70	57	48	46	51	59	67

Volumetric flow controller VRAR

Flow generated noise

VRAR-...-RS-N, with duct silencer L1=1450

Pressure loss 500 Pa and 1000 Pa

NW	v _K (m/s)	V (m ³ /h) [l/s]		Δp _t = 500 Pa									Δp _t = 1000 Pa								
				L _W [dB/oct]								L _{WA} [dB(A)]	L _W [dB/oct]								L _{WA} [dB(A)]
				63	125	250	500	1000	2000	4000	8000		63	125	250	500	1000	2000	4000	8000	
100	3	80	22	33	26	<15	<15	<15	<15	<15	<15	15	50	33	<15	<15	<15	<15	<15	22	26
	6	160	44	37	39	<15	<15	<15	<15	<15	18	24	54	39	17	<15	<15	<15	<15	29	32
	9	239	66	45	47	22	<15	<15	<15	<15	22	31	61	47	24	15	<15	<15	<15	31	37
	12	319	89	48	49	23	<15	<15	<15	<15	24	33	65	48	27	20	18	17	17	35	41
125	3	126	35	42	30	<15	<15	<15	<15	<15	17	20	53	37	15	<15	<15	<15	<15	26	30
	6	252	70	46	43	21	<15	<15	<15	<15	22	28	57	43	24	<15	<15	<15	19	33	35
	9	379	105	54	51	29	<15	<15	<15	<15	26	36	64	51	31	17	16	16	22	35	41
	12	505	140	57	53	30	15	<15	<15	17	28	38	68	54	34	22	20	19	26	39	44
160	3	209	58	49	35	21	<15	<15	<15	15	28	29	56	42	26	<15	<15	<15	24	35	36
	6	418	116	53	48	32	<15	<15	<15	21	33	36	60	48	35	17	<15	<15	30	42	43
	9	627	174	61	56	40	18	<15	<15	25	37	42	67	56	42	22	18	19	33	44	47
	12	836	232	64	58	41	20	<15	<15	28	39	45	71	59	45	27	22	22	37	48	50
200	3	329	91	55	40	27	<15	<15	<15	19	31	33	59	47	32	16	<15	<15	28	39	40
	6	658	183	59	53	38	20	<15	<15	25	36	40	63	53	41	24	15	18	34	46	47
	9	987	274	67	61	46	25	<15	<15	29	40	47	70	61	48	29	20	24	37	48	51
	12	1316	366	70	63	47	27	15	16	32	43	50	74	64	51	34	24	27	41	52	54
225	3	418	116	56	42	30	15	<15	<15	22	33	35	60	49	35	21	<15	15	31	41	42
	6	836	232	60	55	41	25	<15	15	28	38	42	64	55	44	29	17	21	37	48	49
	9	1253	348	68	63	49	30	15	17	32	42	49	71	63	51	34	22	27	40	50	53
	12	1671	464	71	65	50	32	17	19	35	44	51	75	66	54	39	26	30	44	54	56
250	3	517	144	59	44	33	18	<15	<15	24	35	37	62	51	38	24	15	17	33	43	44
	6	1034	287	63	57	44	28	15	17	30	40	45	66	57	47	32	21	23	39	50	51
	9	1552	431	71	65	52	33	19	19	34	44	52	73	65	54	37	26	29	42	52	55
	12	2069	575	74	67	53	35	21	21	37	46	54	77	68	57	42	30	32	46	56	58
280	3	651	181	60	46	36	22	<15	16	28	38	40	63	53	41	28	20	24	37	46	47
	6	1301	361	64	59	47	32	20	24	34	43	47	67	59	50	36	26	30	43	53	54
	9	1952	542	72	67	55	37	24	26	38	47	54	74	67	45	41	31	36	46	55	57
	12	2602	723	75	69	56	39	26	28	41	49	56	78	70	59	46	35	39	50	59	61
315	3	825	229	63	48	39	25	16	20	30	40	42	65	55	44	31	24	28	39	48	49
	6	1651	459	67	61	50	35	24	28	36	45	49	69	61	53	39	30	34	45	55	56
	9	2476	688	75	69	58	40	28	30	40	49	56	76	69	60	44	35	40	48	57	60
	12	3301	917	78	71	59	42	30	32	43	51	58	80	72	63	49	39	43	52	61	63
355	3	1050	292	64	50	41	29	20	24	32	42	44	66	57	46	35	28	32	41	50	51
	6	2101	584	68	63	52	39	28	32	38	47	51	70	63	55	43	34	38	47	57	58
	9	3151	875	76	71	60	44	32	34	42	51	58	77	71	62	48	39	44	50	59	62
	12	4202	1167	79	73	61	46	34	36	45	53	60	81	74	65	53	43	47	54	63	65
400	3	1336	371	56	52	44	33	24	27	35	44	45	67	59	49	39	32	35	44	52	53
	6	2672	742	70	65	55	43	32	35	41	49	54	71	65	58	47	38	41	50	59	60
	9	4009	1114	78	73	63	48	36	37	45	53	60	78	73	65	52	43	47	53	62	64
	12	5345	1485	81	75	64	50	38	39	48	55	62	82	76	68	57	47	50	57	66	68
500	3	2094	582	67	55	49	41	34	34	42	47	50	69	62	54	47	42	42	51	55	57
	6	4188	1163	71	76	68	56	46	44	52	56	58	73	68	63	55	48	48	57	62	64
	9	6282	1745	79	76	68	56	46	44	52	56	64	80	76	70	60	53	54	60	64	68
	12	8377	2327	82	78	68	58	48	46	55	58	66	84	79	73	65	57	57	64	68	72
630	3	3333	926	70	60	54	45	40	51	45	52	55	72	67	59	51	48	49	54	60	62
	6	6666	1852	74	73	65	55	48	49	51	57	63	76	73	68	59	54	55	60	67	69
	9	9999	2778	82	81	73	60	52	51	55	61	69	83	81	75	64	59	61	63	69	73
	12	13332	3703	85	83	74	62	54	53	58	63	71	87	84	78	69	63	64	67	73	77

Volumetric flow controller VRAR

Flow generated noise

VRAR-...-RS-N, with duct silencer L1=1950

Pressure loss 125 Pa and 250 Pa

NW	v _k (m/s)	V (m ³ /h) [l/s]		Δp _f = 125 Pa									L _{WA} [dB(A)]	Δp _f = 250 Pa									L _{WA} [dB(A)]	
				L _W [dB/oct]								L _{WA} [dB(A)]		L _W [dB/oct]								L _{WA} [dB(A)]		
				f _m (Hz)										f _m (Hz)										
63	125	250	500	1000	2000	4000	8000	63	125	250	500	1000	2000	4000	8000	63	125	250	500	1000	2000	4000	8000	
100	3	80	22	24	<15	<15	<15	<15	<15	<15	<15	1	28	<15	<15	<15	<15	<15	<15	<15	<15	<15	<15	4
	6	160	44	32	24	<15	<15	<15	<15	<15	<15	10	34	27	<15	<15	<15	<15	<15	<15	<15	<15	<15	13
	9	239	66	36	25	<15	<15	<15	<15	<15	<15	12	39	33	<15	<15	<15	<15	<15	<15	<15	<15	<15	18
	12	319	89	42	26	<15	<15	<15	<15	<15	<15	17	49	37	<15	<15	<15	<15	<15	<15	<15	<15	<15	25
125	3	126	35	32	16	<15	<15	<15	<15	<15	<15	8	37	19	<15	<15	<15	<15	<15	<15	<15	<15	<15	25
	6	252	70	40	30	<15	<15	<15	<15	<15	<15	17	43	33	<15	<15	<15	<15	<15	<15	<15	<15	<15	32
	9	379	105	44	31	<15	<15	<15	<15	<15	<15	20	48	39	<15	<15	<15	<15	<15	<15	<15	<15	<15	37
	12	505	140	50	32	<15	<15	<15	<15	<15	<15	24	58	43	15	<15	<15	<15	<15	<15	<15	<15	<15	44
160	3	209	58	35	21	<15	<15	<15	<15	<15	<15	14	40	24	<15	<15	<15	<15	<15	<15	<15	<15	<15	16
	6	418	116	43	35	<15	<15	<15	<15	<15	<15	21	46	38	19	<15	<15	<15	<15	<15	<15	17	25	
	9	627	174	47	36	16	<15	<15	<15	<15	<15	24	51	44	24	<15	<15	<15	<15	<15	<15	20	30	
	12	836	232	53	37	20	<15	<15	<15	<15	<15	28	61	48	28	<15	<15	<15	<15	<15	<15	<15	23	37
200	3	329	91	42	27	<15	<15	<15	<15	<15	17	20	47	30	15	<15	<15	<15	<15	<15	<15	<15	23	25
	6	658	183	50	41	21	<15	<15	<15	<15	18	28	53	44	26	<15	<15	<15	<15	<15	<15	<15	28	32
	9	987	274	54	42	23	<15	<15	<15	<15	19	30	58	50	31	<15	<15	<15	<15	<15	15	31	37	
	12	1316	366	60	43	27	<15	<15	<15	<15	19	35	68	54	35	<15	<15	<15	<15	<15	16	34	44	
225	3	418	116	44	30	<15	<15	<15	<15	<15	18	21	48	33	18	<15	<15	<15	<15	<15	<15	24	26	
	6	836	232	52	44	24	<15	<15	<15	<15	18	30	54	47	29	<15	<15	<15	<15	<15	15	29	34	
	9	1253	348	56	45	26	<15	<15	<15	<15	19	32	59	53	34	<15	<15	<15	<15	<15	18	32	39	
	12	1671	464	62	46	30	<15	<15	<15	<15	20	37	69	57	38	15	<15	<15	<15	<15	19	35	45	
250	3	517	144	47	32	16	<15	<15	<15	<15	21	24	51	35	22	<15	<15	<15	<15	<15	<15	27	29	
	6	1034	287	55	46	28	<15	<15	<15	<15	22	33	57	49	33	<15	<15	<15	<15	<15	18	32	37	
	9	1552	431	59	47	30	<15	<15	<15	<15	23	35	62	55	38	17	<15	<15	<15	<15	21	35	42	
	12	2069	575	65	48	34	<15	<15	<15	<15	23	40	72	59	42	18	<15	<15	<15	<15	22	38	48	
280	3	651	181	48	34	20	<15	<15	<15	<15	22	26	52	37	26	<15	<15	<15	<15	<15	17	30	31	
	6	1301	361	56	48	32	<15	<15	<15	15	25	35	58	51	37	16	<15	<15	<15	<15	23	35	39	
	9	1952	542	60	49	34	<15	<15	<15	15	25	37	63	57	42	23	<15	<15	<15	<15	26	38	44	
	12	2602	723	66	50	38	17	<15	<15	<15	17	26	41	73	61	46	24	<15	<15	<15	15	27	41	50
315	3	825	229	50	36	23	<15	<15	<15	<15	25	28	52	33	18	<15	<15	<15	<15	<15	<15	31	32	
	6	1651	459	58	50	35	16	<15	<15	<15	17	27	37	58	47	29	<15	<15	<15	<15	18	36	38	
	9	2476	688	62	51	37	16	<15	<15	<15	17	28	39	63	53	40	22	<15	<15	<15	17	26	39	42
	12	3301	917	68	52	41	22	<15	<15	<15	19	28	43	73	57	38	21	<15	<15	<15	18	28	42	49
355	3	1050	292	51	39	26	<15	<15	<15	<15	17	28	30	56	42	32	15	<15	<15	<15	<15	22	35	36
	6	2101	584	59	53	38	19	<15	<15	<15	20	28	39	62	56	43	24	<15	<15	<15	17	28	40	44
	9	3151	875	63	54	40	19	<15	<15	<15	20	29	41	67	62	48	31	<15	<15	<15	21	31	43	49
	12	4202	1167	69	55	44	25	<15	<15	<15	22	30	45	77	66	52	32	16	22	22	32	32	46	54
400	3	1336	371	52	41	29	<15	<15	<15	<15	20	30	32	59	44	35	20	<15	<15	<15	17	25	37	39
	6	2672	742	60	55	41	24	<15	<15	15	23	31	41	65	58	46	29	15	23	31	31	42	46	
	9	4009	1114	64	56	43	24	<15	<15	16	23	32	43	70	64	51	36	20	27	34	34	45	51	
	12	5345	1485	70	57	47	30	<15	<15	19	25	32	46	80	68	55	37	22	28	35	35	48	57	
500	3	2094	582	54	45	35	24	15	20	28	35	37	59	48	41	30	20	25	33	32	38	42	43	
	6	4188	1163	62	59	47	34	21	23	31	35	45	65	62	52	39	27	31	39	39	47	51	51	
	9	6282	1745	66	60	49	34	21	24	31	36	47	70	68	57	46	32	35	42	50	55	55		
	12	8377	2327	72	61	53	40	26	27	33	37	50	80	72	61	47	34	36	43	53	60	60		
630	3	3333	926	57	50	41	31	25	27	33	39	42	62	53	47	37	30	32	38	46	48	48		
	6	6666	1852	65	64	53	41	31	30	36	40	50	68	67	58	46	37	38	44	51	56	56		
	9	9999	2778	69	65	55	41	31	31	36	41	52	73	73	67	56	45	45	47	54	61	61		
	12	13332	3703	75	66	59	47	36	34	38	41	55	83	77	67	54	44	43	48	57	65	65		

Volumetric flow controller VRAR

Flow generated noise

VRAR-...-RS-N, with duct silencer L1=1950

Pressure loss 500 Pa and 1000 Pa

NW	v _K (m/s)	V (m ³ /h) [l/s]		Δp _t = 500 Pa								Δp _t = 1000 Pa									
				L _W [dB/oct]								L _{WA} [dB(A)]	L _W [dB/oct]								L _{WA} [dB(A)]
				63	125	250	500	1000	2000	4000	8000		63	125	250	500	1000	2000	4000	8000	
100	3	80	22	32	18	<15	<15	<15	<15	<15	<15	9	49	25	<15	<15	<15	<15	<15	<15	23
	6	160	44	36	31	<15	<15	<15	<15	<15	<15	17	53	31	<15	<15	<15	<15	<15	19	28
	9	239	66	44	39	16	<15	<15	<15	<15	<15	24	60	39	18	15	<15	<15	<15	21	34
	12	319	89	47	41	17	<15	<15	<15	<15	<15	27	64	40	21	20	18	27	<15	25	38
125	3	126	35	32	18	<15	<15	<15	<15	<15	<15	9	49	25	<15	<15	<15	<15	<15	<15	23
	6	252	70	36	31	<15	<15	<15	<15	<15	<15	17	53	31	<15	<15	<15	<15	<15	19	28
	9	379	105	44	39	16	<15	<15	<15	<15	<15	24	60	39	18	15	<15	<15	<15	21	34
	12	505	140	47	41	17	<15	<15	<15	<15	<15	27	64	40	21	20	18	27	<15	25	38
160	3	209	58	47	29	<15	<15	<15	<15	<15	21	24	54	36	17	<15	<15	<15	<15	28	31
	6	418	116	51	42	23	<15	<15	<15	<15	26	30	58	42	26	<15	<15	<15	19	35	37
	9	627	174	59	50	31	15	<15	<15	<15	30	37	65	50	33	19	18	18	22	37	42
	12	836	232	62	52	32	17	<15	<15	17	32	39	69	53	36	24	22	21	26	41	45
200	3	329	91	53	35	19	<15	<15	<15	<15	26	29	57	42	24	<15	<15	<15	19	34	36
	6	658	183	57	48	30	<15	<15	<15	16	31	36	61	48	33	16	15	<15	25	41	42
	9	987	274	65	56	38	17	<15	<15	20	35	43	68	56	40	21	20	20	28	43	46
	12	1316	366	68	58	39	19	15	<15	23	38	45	72	59	43	26	24	23	32	47	50
225	3	418	116	54	38	22	<15	<15	<15	<15	28	31	58	45	27	<15	<15	<15	22	36	37
	6	836	232	58	51	33	<15	<15	<15	19	33	38	62	51	36	17	16	15	28	43	44
	9	1253	348	66	59	41	18	<15	<15	23	37	45	69	59	43	22	21	21	31	45	48
	12	1671	464	69	61	42	20	16	<15	26	39	47	73	62	46	27	25	24	35	49	52
250	3	517	144	57	40	26	<15	<15	<15	16	31	34	60	47	31	<15	<15	<15	25	39	40
	6	1034	287	61	53	37	16	<15	<15	22	36	41	64	53	40	20	17	17	31	46	46
	9	1552	431	69	61	45	21	15	<15	26	40	48	71	61	47	25	22	23	34	48	51
	12	2069	575	72	63	46	23	17	15	29	42	50	75	64	50	30	26	26	38	52	54
280	3	651	181	58	42	30	<15	<15	<15	21	34	36	61	49	35	18	<15	18	30	42	43
	6	1301	361	62	55	41	22	<15	18	27	39	43	65	55	44	26	18	24	36	49	49
	9	1952	542	70	63	49	27	16	20	31	43	50	72	63	50	31	23	30	39	51	53
	12	2602	723	73	65	50	29	18	22	34	45	52	76	66	53	36	27	33	43	55	57
315	3	825	229	61	44	33	17	<15	15	23	37	39	63	51	38	23	<15	23	32	45	45
	6	1651	459	65	57	44	27	<15	23	29	42	46	57	57	47	31	19	29	38	52	52
	9	2476	688	73	65	52	32	17	25	33	46	52	74	65	54	36	27	35	41	54	56
	12	3301	917	76	67	53	34	19	27	36	48	55	78	68	57	41	28	38	45	58	60
355	3	1050	292	62	47	36	20	<15	17	26	39	41	64	54	41	26	16	25	35	47	48
	6	2101	584	66	60	47	30	16	25	32	44	48	68	60	50	34	22	31	41	54	54
	9	3151	875	74	68	55	35	20	27	36	48	55	75	68	57	39	27	37	44	56	58
	12	4202	1167	77	70	56	37	22	29	39	50	57	79	71	60	44	31	40	48	60	62
400	3	1336	371	54	49	39	25	<15	23	29	41	42	65	56	44	31	22	31	38	49	50
	6	2672	742	68	62	50	35	22	31	35	46	50	69	62	53	39	28	37	44	56	56
	9	4009	1114	76	70	58	40	26	33	39	50	57	76	70	60	44	33	43	47	59	61
	12	5345	1485	79	72	59	42	28	35	42	52	59	80	73	63	49	37	46	51	63	64
500	3	2094	582	65	53	45	35	26	31	37	46	48	67	60	50	41	34	39	46	54	55
	6	4188	1163	69	66	56	45	34	39	43	51	55	71	66	59	49	40	45	52	61	62
	9	6282	1745	77	74	64	50	38	41	47	55	61	78	74	66	54	45	51	55	63	65
	12	8377	2327	80	76	65	52	40	43	50	57	63	82	77	69	59	49	54	59	67	69
630	3	3333	926	68	58	51	42	36	38	42	50	52	70	65	56	48	44	46	51	58	60
	6	6666	1852	72	71	62	52	44	46	48	55	60	74	71	65	56	50	52	57	65	66
	9	9999	2778	80	79	70	57	48	48	52	59	67	81	79	72	61	55	58	60	67	70
	12	13332	3703	83	81	71	59	50	50	55	61	68	85	82	75	66	9	61	64	71	74

Volumetric flow controller VRAR

Radiated noise VRAR

with insulated connections on both sides

NW	ΔL_W [dB/Okt]					
	f_m (Hz)					
	125	250	500	1000	2000	4000
100	18	22	28	38	38	38
125	18	19	27	37	37	37
160	18	14	26	32	33	33
200	14	15	27	32	34	37
225	13	16	27	32	35	38
250	11	18	28	33	37	40
280	11	19	28	33	38	41
315	12	20	29	34	40	42

(50 mm mineral wool insulation)
(sheet thickness 1 mm)

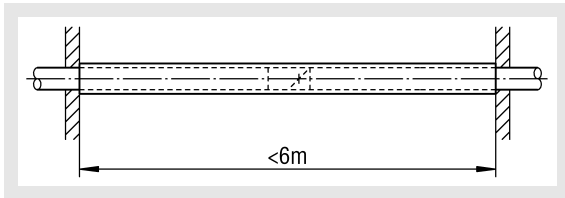

with up to 6 m of spiral duct according to DIN EN 1506

NW	ΔL_W [dB/Okt]					
	f_m (Hz)					
	125	250	500	1000	2000	4000
100	23	24	24	22	18	15
125	19	23	23	19	18	14
160	18	20	23	18	16	12
200	15	18	21	18	14	11
225	14	17	20	18	14	12
250	13	16	18	18	14	14
280	12	15	18	18	13	14
315	11	13	19	19	11	14

$L_{Wabst} = L_W - \Delta L_W$ [dB]

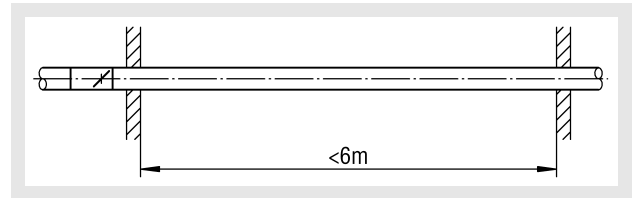

VRAR-...-DS2, with acoustic cladding

NW	ΔL_W [dB/Okt]					
	f_m (Hz)					
	125	250	500	1000	2000	4000
100-315	7	4	4	9	13	15

20 mm mineral wool insulation

With a straight supply and return air flow of 3 m each, the VRAR acoustic cladding reduces the radiated noise by 8 dB(A).

Volumetric flow controller VRAR

Technical data of the control components

Measured value collection and control function

The measured value collection is carried out via a flow-favouring double measuring cross. The measuring openings are distributed over the measuring cross according to the median line method. The pressure differential formed on the measuring cross is determined by means of a dynamic or static measuring sensor. The measured values are averaged to give an average value which represents a measuring quantity for the volumetric flow. The controller compares the actual value signal with the setpoint value and sends an output signal to the electric actuator which adjusts the controller deviation independent of pressure changes in the duct network.

The volumetric flow controllers of the Belimo make (Compact, Universal) and the Gruner make are delivered by SCHAKO as standard with the operating mode (Y signal, U_5 signal) 2-10 V DC. When activated by 2 V DC, the V_{min} volume is controlled, the smallest possible V_{min} volume that can be controlled can be seen from the "Volumetric Flow Range" tables. **When the air volume drops below the V_{min} shown in the chart, the correct functioning of the volumetric flow controller is no longer guaranteed!**

Positive control damper "CLOSED"

Airtight sealing to DIN EN 1751 is achieved on site either via a positive control "CLOSED" by means of a switch or a relay, or via an actuator signal of 0 V DC applied to the input Y (all Compact controllers equipped with the operating mode 2-10V DC). Accordingly, the the drive will likewise close the flap in operating range 2 - 10 V DC (however, this does not apply to the operating range 0-10 V DC), and the VAV control will be inactive. To do so, it must be ensured that the actuator signal is < 0.1 V DC. This is why in rooms where defined pressures are active (e.g. laboratories), the flap should be closed via a digital on-site switching contact.

If the Compact controllers of the Belimo make must be delivered with the operating mode 0-10V DC on customer request, please note that a positive control "CLOSED" can only be effected via a switching contact with diode.

Positive control damper "OPEN"

Supports smoke extraction or is used as a safety position. The volumetric flow controller is in this case inactive, and the damper is driven to the mechanical open position. In this case, it is recommended using an actuator with spring return function (e.g. Belimo make, actuator type VRU-... with NF24A-VST). This ensures that the actuator flap will be driven into the defined "OPEN" end position also via an digital contact or in case of power failure.

V_{min} control to a minimum volumetric flow

Depending on requirement or by not assigning them, individual areas can be set to stand-by operation. In this way, minimum room flushing with greatly reduced energy expenditure is achieved.

V_{max} control to a max. volumetric flow

Individual or several rooms are supplied for a short period with a maximum volumetric flow. This allows, for example, a room through-ventilation or efficient heating to be effected.

Continuous operation

As a function of the continuous driving signal and the programmed operating range (0-10 V DC or 2-10 V DC), the volumetric flow controller will regulate the volumetric flow linearly between the setpoint values of V_{min} and V_{max} .

Constant operation















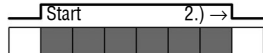

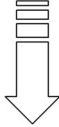

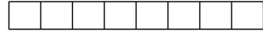

If terminal 3 (Y command signal) has not been assigned, the value set from V_{min} is controlled as a constant volumetric flow.

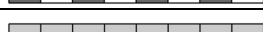

Two-stage volumetric flow rate control

- Stage 1: If terminal 3 (Y command signal) has not been assigned, the value set from V_{min} is controlled as a constant volumetric flow.
- Stage 2: If AC 24 V is applied to terminal 3, the volumetric flow controller keeps the value set as V_{max} constant. With a switch or a contact in a connection line a "secondary volume flow control" is possible.

Volumetric flow controller VRAR

LED table of functions for LMV-D3-MP / NMV-D3-MP

Application	Function	Description / action	LED pattern	Adaption Address	⊕ LED 1 power ⊕ LED 2 status
N1 operation	Status display	- 24 V power supply o.k. - - VAV-Compact ready for operation	LED 1 LED 2	 	
S1 service function	Synchronisation	Synchronisation started by: a) Operating / service unit b) Manual trigger device at the VAV-Compact c) Power ON behaviour	LED 1 LED 2	 	
S2 service function	Adaption	Adaptation started by: a) Operating / service unit b) Key on the VAV-Compact	LED 1 LED 2	 	
V1 VAV service	VAV service active	a) Simultaneously press both keys «Adaptation» & «Address» b) VAV service will be activated: - until 24 V supply is switched off - until both keys are pressed again - after 2 hours have passed	LED 1 LED 2	  	
	Lack of air	Damper opens as actual volume is too low	LED 1 LED 2	 	
	Target volume reached	Control circuit balanced	LED 1 LED 2	 	
	Air excess	Damper closes as actual volume is too high	LED 1 LED 2	 	
B1 bus operation	Addressing via MP master (Acknowledgement at the VAV-Compact)	a) Addressing has been triggered at the MP master	LED 1 LED 2	 	
		b) Press addressing key LED will switch to the communication display as soon as the addressing process is complete.	LED 1 LED 2	 	
B2 bus operation	Addressing via MP master (with serial number)	Addressing at the MP master was triggered, LED will switch to the communication display as soon as the addressing process is complete.	LED 1 LED 2	 	
B3 bus operation communication	MP-PP display Communication	Communication display via MP master or operating / service unit	LED 1 LED 2	 	

-  green LED (power) is lit
-  yellow LED (status) is lit
-  yellow LED (status) is flashing

- 1.) Synch time
- 2.) Adaptation time
- 3.) MP communication

Volumetric flow controller VRAR

Circuit diagram of electric controller (alternative)
 Universal controller Belimo make VRU-D3/M1-BAC
 VAV with analogue command signal

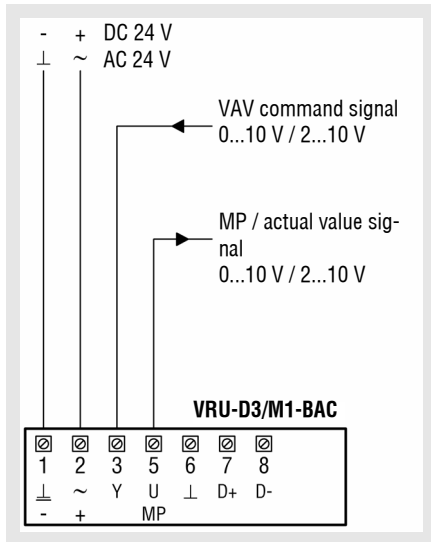

CAV operation

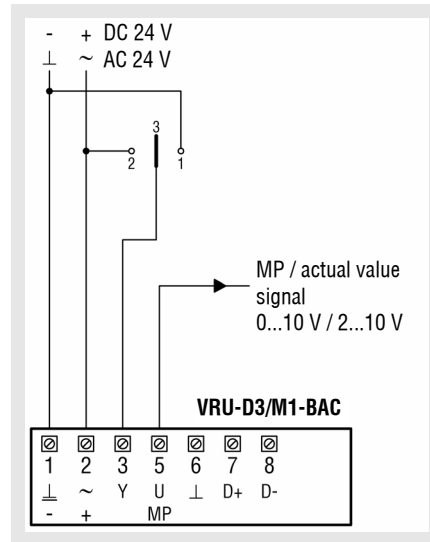

Command signal Y	Volumetric flow	Function
< 0,1 V **	0	Damper CLOSED, VAV control inactive
0,2...2 V	V_{min}	V_{min} operating stage active
2...10 V	$V_{min} \dots V_{max}$	Continuous operation $V_{min} \dots V_{max}$

**Attention: Controller/DDC must be able to pull the command signal to 0 V.

Function - Analogue CAV step control

1. Damper CLOSED
2. V_{max}
3. V_{min}

BACnet MS/TP / Modbus RTU operation

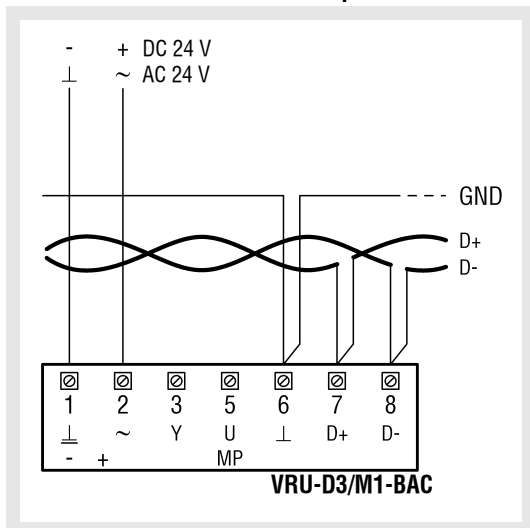

Priority rule - BACnet/Modbus control

1. z1
2. z2
3. Bus watchdog
4. a) Adaptation
b) Synchronisation
5. Bus positive control
6. Bus setpoint value: Min...Max

BACnet MS/TP / Modbus RTU hybrid operation

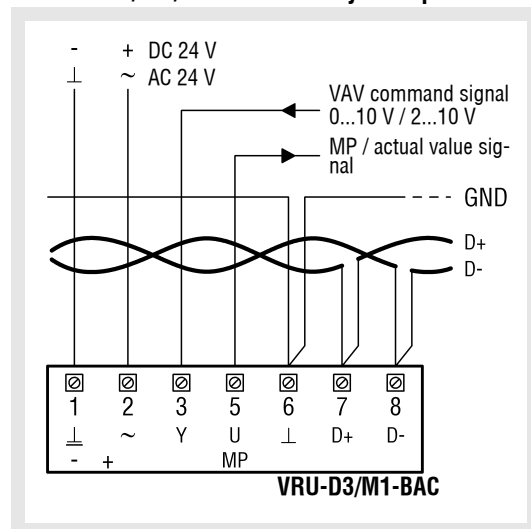

Priority rule - BACnet/Modbus hybrid operation

1. z1
2. z2
3. Bus watchdog
4. a) Adaptation
b) Synchronisation
5. Bus positive control
6. Y stage: actuator CLOSED / MIN / MAX
7. Bus setpoint value: Min...Max

Volumetric flow controller VRAR

Circuit diagram of electric controller (alternative)

Controller Gruner make:
GUAC-SM3/SCH Universal
Connection diagram

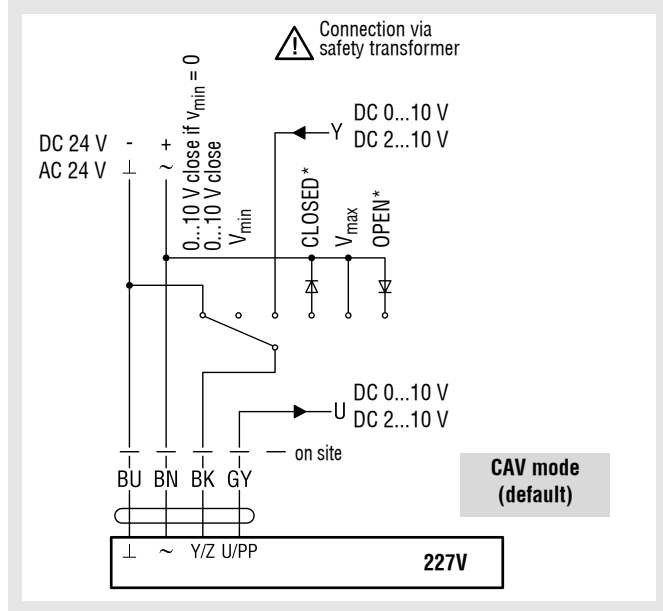

Edit:	The selector value allows values to be changed. The position of the arrow shows the set value. The changes are displayed as soon as the selector is moved $\pm 10^\circ$ out of its position.
Flow / Unit:	To set the desired current volumetric flow unit in m^3/h and l/s .
V_{\min} :	To set the required min. volumetric flow (setpoint value $Y = 0 \text{ V} / 2 \text{ V}$)
V_{\max} :	To set the required max. volumetric flow (setpoint value $Y = 10 \text{ V}$)
Mode:	(To set the direction of rotation) 0-n...0-10 V normal (clockwise) 2-n...2-10 V normal (clockwise) 0-i ...0-10 V inverse (counterclockwise) 2-i ...2-10 V inverse (counterclockwise)
Diag:	Diagnosics menu: oP = opens the damper leaf cL = closes the damper leaf Hi = activates V_{\max} Lo = activates V_{\min} on = Diagnostic mode is on, motor is off off = Diagnostic mode is off, display Y setpoint
V_{nom} :	To display and set the nominal volumetric flow (by the box manufacturer only).
(for more information, please refer to the technical data sheet GUAC-SM3/SCH Universal 327VM-024-05-VM from Gruner)	

Setting

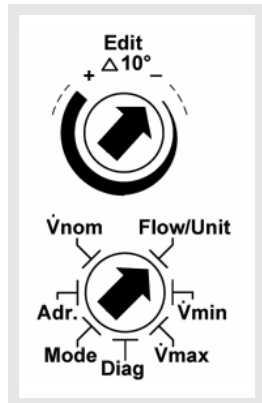

Volumetric flow controller VRAR

Circuit diagram of electric controller (alternative)

Controller Gruner make 327V? Compact Connection diagram

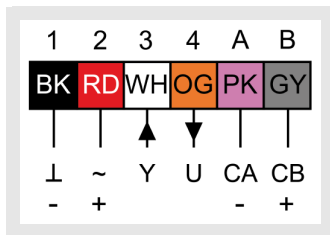
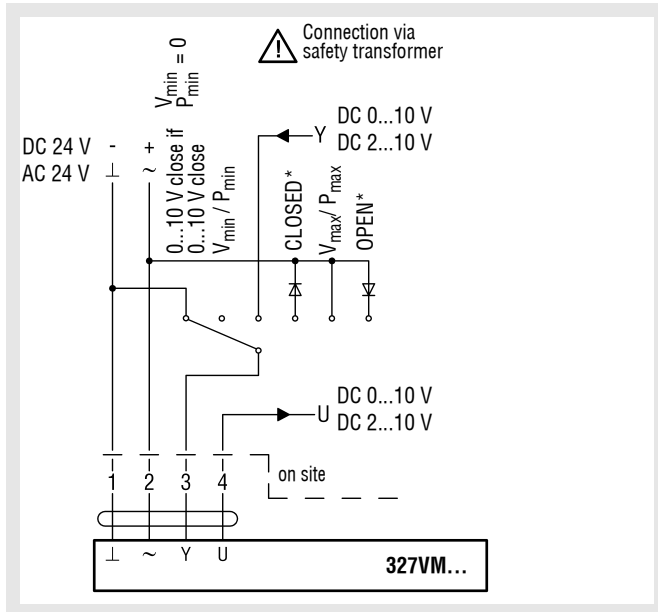

No.	Designation	Wire colour	Function
1	—	-	Power supply 24 V AC/DC
2	—	+	
3	←	Y	Input signal 0-10 V DC
4	→	U	Feedback signal 0-10 V DC
A	CA -	pink	Modbus RTU connection (RS485)
B	CB +	grey	

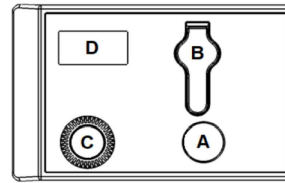

- A = LED button
- B = Service connection
- C = Rotary selector switch
- D = Display

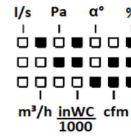

- I/s (volume) = No square is shown in the display
- m³/h (volume) = Only the upper square is shown in the display
- Pa (pressure) = Only the middle square is shown in the display
- inWC/1000 = The upper & the middle square are shown in the display
- α° (angle) = Only the lower square is shown in the display
- Cfm = The middle & the lower square are shown in the display

Act / Set:	Display of current value / setpoint value or positive control.
Min:	To set the required min. value (setpoint value Y = 0 / 2 VDC).
Max:	To set the required max. value (setpoint value Y = 10 VDC).
Diag:	Diagnostics menu: y/u - Display of setpoint value / feedback signal oP - opens the damper leaf cL - closes the damper leaf Hi - activates max. value Lo - activates min. value bE - activates intermediate value St - diagnostic mode is on, motor is off Adp - adaptation travel (only 15 Nm or Modbus version) 123 - software version
Mode:	0An (0-10 V DC standard direction of rotation) 2An (2-10 V DC standard direction of rotation)
Addr.:	Setting the Modbus address (1...247) and Modbus parameters (if actuator is Modbus-capable).
Nom:	Display & setting of the nominal value, depending on the VAV box (setting is only possible with volumetric flow rate control).
Settings:	327 VAV controllers can be set directly on the display. All 327 VAV controllers can communicate with the setting device GUIV3-M or with the setting software Win-VAV2 via the service connection. When using the setting software WIN-VAV2, the GUIV3-S serves as an interface converter.
Accessories:	GUIV3-M – service plug + setting device GUIV3-M WIN-VAV2 bundle – service plug + interface converter GUIV3-S + setting software WIN-VAV2

Volumetric flow controller VRAR

Circuit diagram of electric controller (alternative)

Controller make Siemens: GLB181.1 E/3
Connection diagram

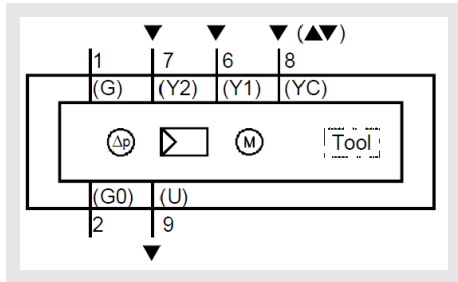

Controller make Siemens: GDB181.1 E/KN / GLB181.1 E/KN
Connection diagram for KNX

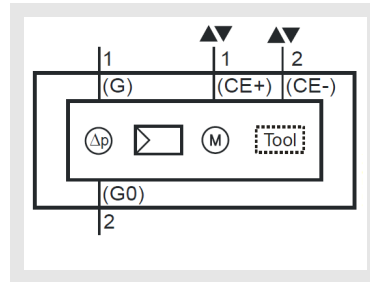

Constant control between V_{max} and V_{min} and complete lock

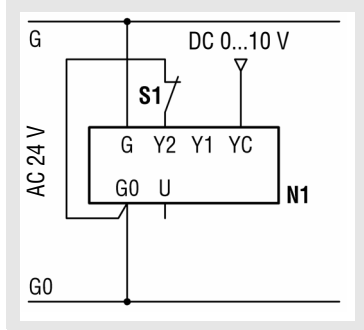

The wires of the connecting cable are colour-coded and labelled:

AB	AF	CO	Meaning
Cable 1: supply / black sheath			
1	red	G	Voltage phase AC 24 V
2	black	G0	Voltage neutral conductor AC 24 V
Cable 2: bus connection / green sheath			
1	red	CE+	Bus connection (KNX / PL-Kink)
2	black	CE-	Bus connection (KNX / PL-Kink)

AB = Wire labelling

AF = Wire colour

CO = Terminal code (Landis & Staefa)

The wires of the connecting cable are colour-coded and labelled:

AB	AF	CO	Meaning
1	red	G	Phase AC 24 V
2	black	G0	System zero AC 24 V
6	violet	Y1	"Actuator direction of rotation" actuator signal (G0 switched), depends on the setting of AST10 or ACS931 (factory setting=clockwise rotation)
7	orange	Y2	"Actuator direction of rotation" actuator signal (G0 switched), depends on the setting of AST10 or ACS931 (factory setting=counter-clockwise rotation)
8	grey	YC	Volumetric flow command signal DC 0...10 V (setpoint) or communication signal, with connected setting device AST10 or interface converter AST11
9	pink	U	Volumetric flow measuring signal DC 0...10 V (actual value)

AB = Wire labelling

AF = Wire colour

CO = Terminal code (Landis & Staefa)

Volumetric flow controller VRAR

Circuit diagram of electric controller (alternative)

Controller make Delta Controls DVC-V322A / DVC-V322AF

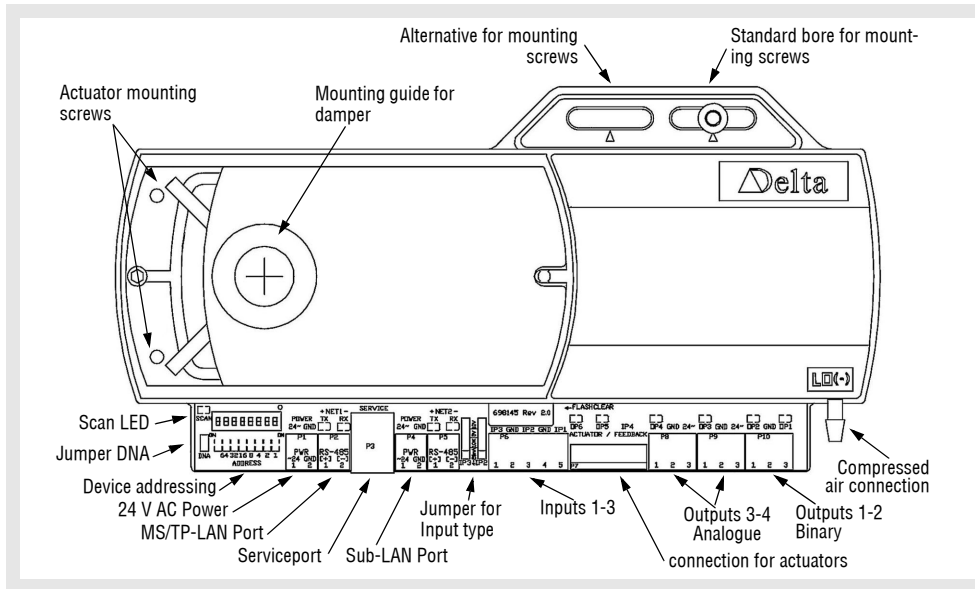

Accessories:

- RPT-768 - Delta network repeater for BACnet MS/TP
- TRM-768 - Delta network terminator for BACnet MS/TP
- CON-768 - Delta network converter

Circuit diagram of pneumatic controller (standard) Compact controller Sauter make RLP100 F003

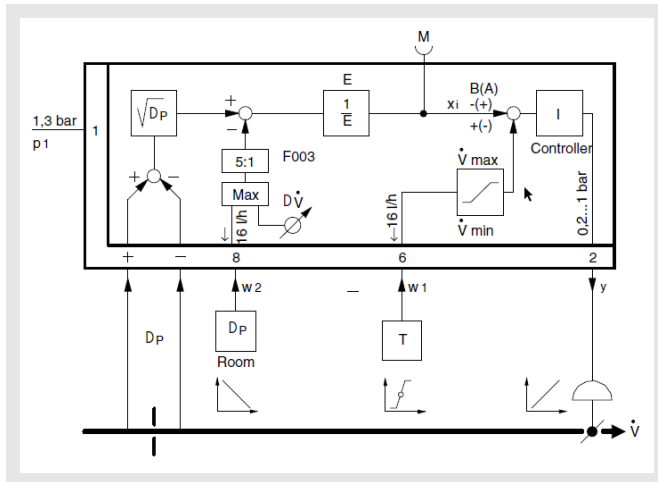

Circuit diagram of pneumatic controller (alternative) Compact controller Sauter make RLP100 F914

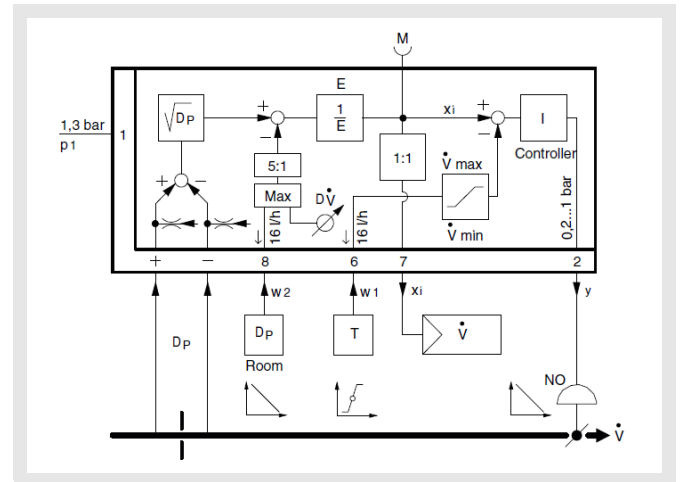

- w = Command variable
- Δp = Pressure difference
- v = Output pressure
- y (2) = Output to the actuator

Volumetric flow controller VRAR

Calculation formulae

Calculation of the U_5 voltage value

Operating mode: 2 - 10 V DC:

$$U_5 = \frac{V_{\max}}{V_{\text{nenn}}} \times 8V + 2V \quad V_{\max} \text{ values}$$

$$U_5 = \frac{V_{\min}}{V_{\text{nenn}}} \times 8V + 2V \quad V_{\min} \text{ values}$$

Operating mode: 0 - 10 V DC:

$$U_5 = \frac{V_{\max}}{V_{\text{nenn}}} \times 10V \quad V_{\max} \text{ values}$$

$$U_5 = \frac{V_{\min}}{V_{\text{nenn}}} \times 10V \quad V_{\min} \text{ values}$$

Calculation of the V_{nenn} volumetric flow

$$V_{\text{nenn}} = EK \times F \times 3600$$

Attention:

The V_{nenn} value changes as a function of the set calibration curve. The standard calibration curve is 12 m/s.

EW (%)	=	Set value
EK (m/s)	=	Calibration curve
U_5 (V DC)	=	U_5 signal
F (m ²)	=	Area

Volumetric flow controller VRAR

Actual value measurement via feedback signal U_5 using a voltmeter or PC tool

Terminal assignment
LMV-D3-MP / NMV-D3-MP

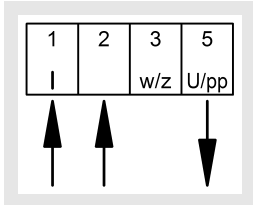

Supply voltage: 24 V AC/DC (terminals 1+2)
Measurement output 2 - 10 V DC (terminals 1+5)
Measurement output 0 - 10 V DC (terminals 1+5)

The actual value signal U_5 is a real feedback of the volumetric flow actual value for monitoring and controlling the air through-put volume.

327VM/GUAC-...

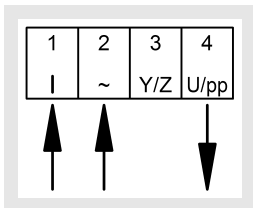

Supply voltage: 24 V AC/DC (terminals 1+2)
Measurement output 2 - 10 V DC (terminals 1+4)
Measurement output 0 - 10 V DC (terminals 1+4)

U_5 signal 0-10 V DC

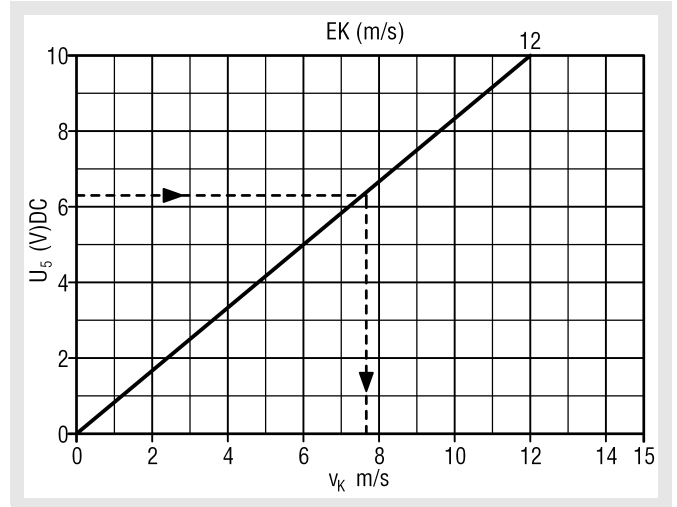

Example

Assume: Measurement output signal $U_5 = 6.3$ V DC
Calibration value VRAR = 12 m/sec

Measured value: Duct velocity = 7.6 m/s

Air volume: Duct velocity x area m^2 x 3600 = m^3/h

U_5 signal 2-10 V DC

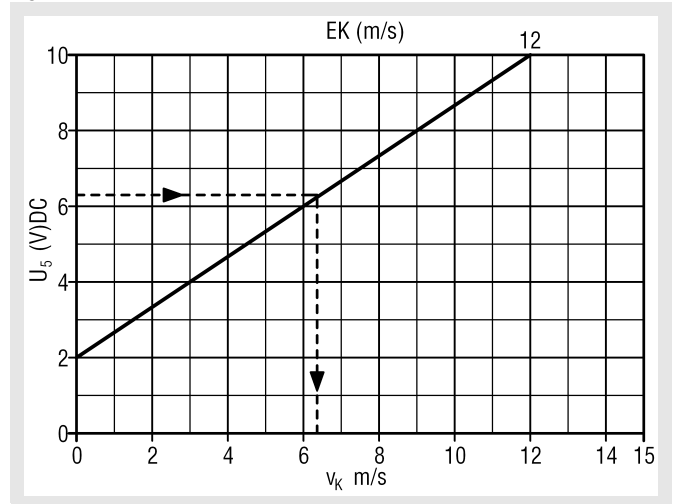

Example

Assume: Measurement output signal $U_5 = 6.3$ V DC
Calibration value VRAR = 12 m/sec

Measured value: Duct velocity = 6.3 m/s

Air volume: Duct velocity x area m^2 x 3600 = m^3/h

Volumetric flow controller VRAR

Room pressure control

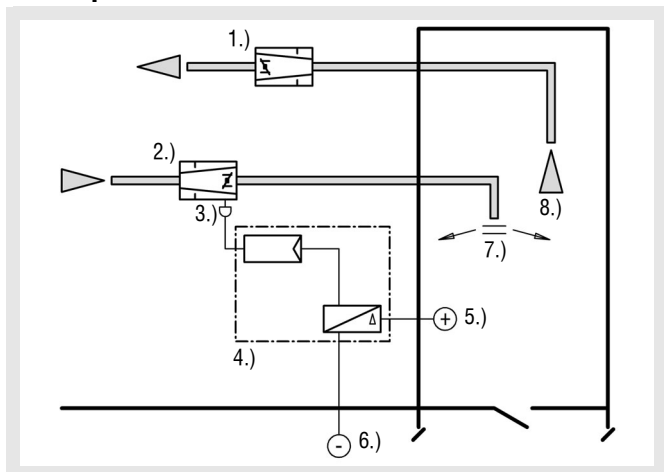

- 1.) Volumetric flow controller VRAR with electric controller
- 2.) Damper DKA / HK / JK
- 3.) Actuator LMQ24A-VST
- 4.) Room pressure controller VRU-M1R-BAC
- 5.) Overpressure regulation, relative to the reference room
- 6.) Reference room
- 7.) Supply air
- 8.) Return air

To maintain the required positive or negative pressure, relative to a suitable reference room, the damper is used as room pressure controller on the supply air side, i.e., the pressure is controlled as a linear function and not as a function of the volumetric flow. The pressure difference between the room to be regulated and the reference room is measured by a static differential pressure sensor, which detects the pressure level and the sign (positive pressure or negative pressure). According to the pressure difference measured, the room pressure controller adjusts the control flap of the supply air volumetric flow controller via the actuator. The differential pressure sensor is connected to the room to be regulated and to the reference room via measuring pipes. In doing so, the maximum allowed hose length and the mounting position of the pressure sensor must be taken into account. A measuring probe (measuring cross) is not required.

As standard, the pressure regulator Belimo make type **VRU-M1R-BAC** is used for room pressure control together with the high-speed actuator type **LMQ24A-VST**. The room pressure can be set between -75 Pa and +75 Pa.

Duct pressure control

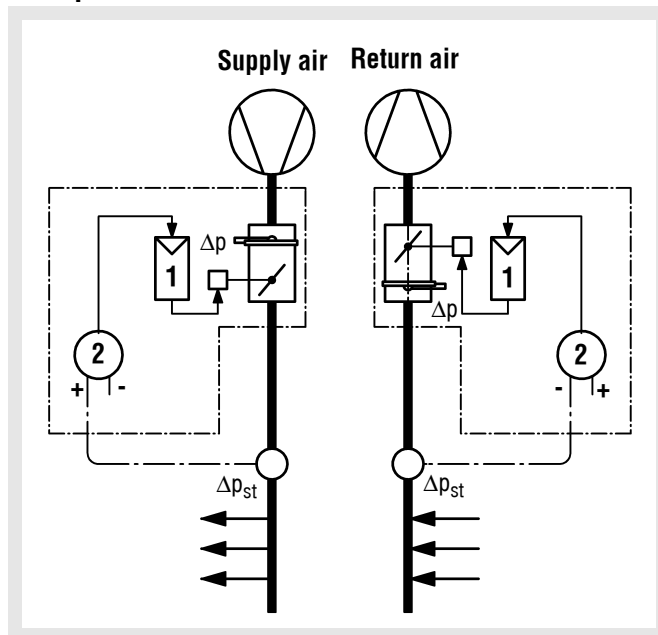

Duct pressure control in the supply air

- static pressure is measured **behind** the damper (in air flow direction)
- TARGET pressure is controlled (**over**pressure)
- connection "+" duct pressure
- connection "-" open

Duct pressure control in the return air

- static pressure is measured **in front of** the damper (in air flow direction)
- TARGET pressure is controlled (**negative** pressure)
- connection "-" duct pressure
- connection "+" open

As standard, the pressure controller Gruner make type 327VM-024-05-DS6-MB with an integrated sensor is used to control duct pressure. It has a measuring range of 0-600 Pa.

Volumetric flow controller VRAR

Supply and return air volumetric flow control

Master/slave activation for VRAR with electric controller Belimo make

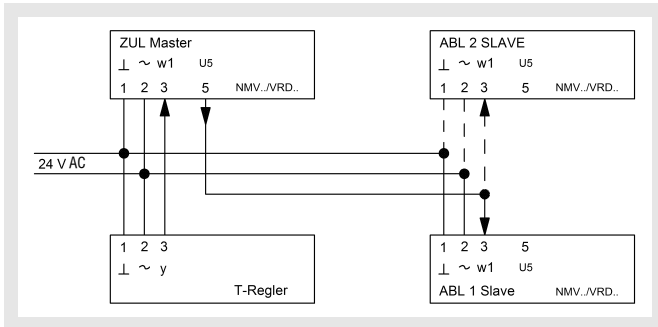

The slave is working sequentially to the master for:

- Installations with volumetric flow controllers in the supply air and return air that have to work sequentially.
- Supply and return air equipment of same size
- Regulation of the supply air/return air ratios

The command signal w of the temperature controller is connected to the input of the supply air volumetric flow controller (master).

The actual value signal of the master is the drive signal for the return air volumetric flow controller (slave).

- The $V_{\text{slave}}/V_{\text{master}}$ ratio is set with the V_{max} value of the slave. This value must be calculated.
- Set V_{min} slave to 0%.
- Apply the V_{min} , V_{max} positive controls to master only and the "CLOSED" one to master and slave.

Parallel activation

for VRAR with electric controller Belimo make

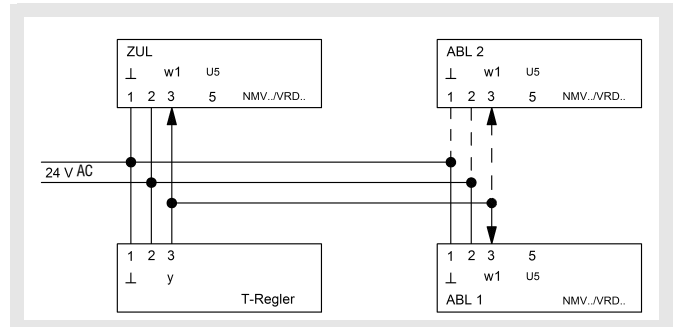

Wiring information

Connect U_5 signal (actual value volumetric flow) always to a readily accessible terminal (switch cabinet, room controller). It is used to connect the setting device ZTH EU (see startup using the setting and diagnostic device ZTH EU).

The control operates for:

- Installations with parallel operation of volumetric flow controllers in supply air and return air (activated by the same command variable).
- Supply and return air installations of different sizes and settings of the minimum and maximum limits.
- Difference regulation between supply and return air.
- Installations with several supply and/or return air devices.

The command signal w of the temperature control is connected in parallel to the setpoint inputs of the supply and return air volumetric flow controllers VR...

The minimum and maximum limits of the volumetric flow must be set for each controller.

Volumetric flow controller VRAR

Technical data of controllers and motors

Standard electric controller

LMV-D3-MP (make Belimo)

Dynamic pressure sensor, digital VAV controller and damper drive as communication-capable VAV-Compact solution.

Measuring principle:	Pressure reading with volumetric flow
Measuring range sensor:	2... ~ 450 Pa
Supply voltage:	AC 24 V, 50/60 Hz, DC 24 V
Functional range:	AC 19.2...28.8 V / DC 21.6...28.8 V
Power consumption:	2 W
Dimensioning:	3.5 VA
Torque:	min. 5 Nm at the rated voltage
Control function:	VAV/CAV/Open-Loop; Supply/return air or stand-alone operation; master/slave parallel circuit; Mixing box control
Setting range V_{\min}/V_{\max} :	$V_{\min} = 0...100$ % of set V_{nenn} volumetric flow $V_{\max} = 20...100$ % of set V_{nenn} volumetric flow
Command variable w/Y : (Input resistance min. 100 k Ω)	DC 2-10 V (4...20 mA with 500 Ω input resistance) DC 0-10 V (0...20 mA with 500 Ω input resistance) adjustable DC 0...10 V
Setting range actual value signal U_5 :	DC 2...10 V DC 0...10 V
MP bus function Address in bus mode:	1 ... 8 (traditional operation: PP)
KNX/MODBUS RTU/ BACnet:	with BELIMO gateway UK24MOD/-BAC, 1 ... 8 BELIMO MP devices (VAV / flap drive / valve)
DDC controller:	DDC controller / PLC from different manufacturers, with integrated MP interface
Sensor connection:	Passive (Pt1000, Ni1000, etc.) and active sensors (0...10 V), for example temperature, humidity, 2-point signal (switching power 16 mA @ 24 V), for example switch, presence detector
Protection class:	III (safety extra low voltage)
Degree of protection:	IP 54 (hose-connected)
EMC:	CE according to 39/336/EEC
Measuring air and ambient temperatures:	0 °C to +50 °C, 5-95% relative humidity, non-condensing
Storage temperature:	-20 °C...+80 °C
Sound power level:	max. 35 dB(A)
Operation and service:	plug-in via service socket / PC-Tool (from V3.1) / ZTH-EU
Communication:	PP/MP bus, max. DC 15V, 1200 baud
Connection:	Cable, 4 x 0.75mm ² , terminals
Weight:	approx. 500 g

NMV-D3-MP (make Belimo)

Dynamic pressure sensor, digital VAV controller and damper drive as communication-capable VAV-Compact solution.

Measuring principle:	Pressure reading with volumetric flow
Measuring range sensor:	2... ~ 450 Pa
Supply voltage:	AC 24 V, 50/60 Hz, DC 24 V
Functional range:	AC 19.2...28.8 V / DC 21.6...28.8 V
Power consumption:	3 W
Dimensioning:	5 VA
Torque:	min. 10 Nm at the rated voltage
Control function:	VAV/CAV/Open-Loop; Supply/return air or stand-alone operation; master/slave parallel circuit; Mixing box control
Setting range V_{\min}/V_{\max} :	$V_{\min} = 0...100$ % of set V_{nenn} volumetric flow $V_{\max} = 20...100$ % of set V_{nenn} volumetric flow
Command variable w/Y : (Input resistance min. 100 k Ω)	DC 2-10 V (4...20 mA with 500 Ω input resistance) DC 0-10 V (0...20 mA with 500 Ω input resistance) adjustable DC 0...10 V
Setting range actual value signal U_5 :	DC 2...10 V DC 0...10 V
MP bus function Address in bus mode:	MP 1 ... 8 (traditional operation: PP)
KNX/MODBUS RTU/ BACnet:	with BELIMO gateway UK24MOD/-BAC, 1 ... 8 BELIMO MP devices (VAV / flap drive / valve)
DDC controller:	DDC controller / PLC from different manufacturers, with integrated MP interface
Sensor connection:	Passive (Pt1000, Ni1000, etc.) and active sensors (0...10 V), for example temperature, humidity, 2-point signal (switching power 16 mA @ 24 V), for example switch, presence detector
Protection class:	III (safety extra low voltage)
Degree of protection:	IP 54 (hose-connected)
EMC:	CE according to 39/336/EEC
Measuring air and ambient temperatures:	0 °C to +50 °C, 5-95% relative humidity, non-condensing
Storage temperature:	-20 °C...+80 °C
Sound power level:	max. 35 dB(A)
Operation and service:	plug-in via service socket / PC-Tool (from V3.1) / ZTH-EU
Communication:	PP/MP bus, max. DC 15V, 1200 baud
Connection:	Cable, 4 x 0.75mm ² , terminals
Weight:	approx. 700 g

Volumetric flow controller VRAR

Alternative electric controller

VRU-D3-BAC (make Belimo)

Self-adapting digital volumetric flow/pressure controller, with integrated dynamic pressure sensor. Position-independent as a communication-capable universal solution with external actuators.

Measuring principle:	dynamic differential pressure measurement
Measuring range sensor:	2... ~500 Pa (bursting pressure +/- 10 kPa)
Sensor functional range:	0... ~500 Pa
Supply voltage:	AC 24 V, 50/60 Hz, DC 24 V
Functional range:	AC 19...29 V / DC 19...29 V
Power consumption:	1.5 W (without actuator)
Dimensioning:	2 VA (with VST actuator)
Control function:	VAV/CAV, STP (pressure), open loop Supply/return air or stand-alone operation; positive control; master/slave or parallel circuit
Setting range: V_{\min}/V_{\max} (volumetric flow)	$V_{\min} = 0...100\%$ of V_{nom} $V_{\max} = 20...100\%$ of V_{nom} $V_{\text{kon.}} = 0...100\%$ of V_{nom}
Setting range: P_{\min} to P_{\max} (pressure)	$P_{\min} = 0...100\%$ of P_{nom} $P_{\max} = 20...100\%$ of P_{nom} $P_{\text{kon.}} = 0...100\%$ of P_{nom}
Bus function:	BACnet MS/TP, Modbus RTU, MP bus
Command variable Y/Z: (inherent resistance min. 100 k Ω)	DC 0-10 V DC 2-10 V variable
Setting range: (actual value signal U)	DC 0-10 V DC 2-10 V variable
Sensor integration:	passive or active sensors (0-10V) for example, humidity, temperature 2-point signal (switching power 16 mA @ 24 V), for example switch, motion detector
Protection class:	III Safety extra-low voltage (SELV)
Degree of protection:	IP42 (measuring hoses and actuator connected)
Ambient temperature:	0 °C to +50 °C (environment), 5-95% relative humidity, non-condensing
Storage temperature:	-20 °C to +80 °C, 5-95% relative humidity, non-condensing
Operation and service:	via the ZTH EU setting device, Belimo Assistant app (NFC, Bluetooth) or via feedback signal/service plug with Belimo PC-Tool
Connection:	Terminals 2.5 mm ²
Dimensions:	170 x 98 x 58 mm
Weight:	approx. 340 g
Maintenance:	maintenance-free

VRU-M1-BAC (make Belimo)

Self-adapting digital volumetric flow/pressure controller, with integrated static pressure sensor. Position-independent as a communication-capable universal solution with external actuators.

Measuring principle:	static differential pressure measurement
Measuring range sensor:	0... ~600 Pa (bursting pressure +/- 10 kPa)
Sensor functional range:	0... ~600 Pa
Supply voltage:	AC 24 V, 50/60 Hz, DC 24 V
Functional range:	AC 19...29 V / DC 19...29 V
Power consumption:	1.5 W (without actuator)
Dimensioning:	2 VA (with VST actuator)
Control function :	VAV/CAV, STP (pressure), open loop Supply/return air or stand-alone operation; positive control; master/slave or parallel circuit
Setting range: V_{\min}/V_{\max} (volumetric flow)	$V_{\min} = 0...100\%$ of V_{nom} $V_{\max} = 20...100\%$ of V_{nom} $V_{\text{kon.}} = 0...100\%$ of V_{nom}
Setting range: P_{\min} to P_{\max} (pressure)	$P_{\min} = 0...100\%$ of P_{nom} $P_{\max} = 20...100\%$ of P_{nom} $P_{\text{kon.}} = 0...100\%$ of P_{nom}
Bus function:	BACnet MS/TP, Modbus RTU, MP bus
Command variable Y/Z: (inherent resistance min. 100 k Ω)	DC 0-10 V DC 2-10 V variable
Setting range: (actual value signal U)	DC 0-10 V DC 2-10 V variable
Sensor integration:	passive or active sensors (0-10V) for example, humidity, temperature 2-point signal (switching power 16 mA @ 24 V), for example switch, motion detector
Protection class:	III Safety extra-low voltage (SELV)
Degree of protection:	IP42 (measuring hoses and actuator connected)
Ambient temperature:	0 °C to +50 °C (environment), 5-95% relative humidity, non-condensing
Storage temperature:	-20 °C to +80 °C, 5-95% relative humidity, non-condensing
Operation and service:	via the ZTH EU setting device, Belimo Assistant app (NFC, Bluetooth) or via feedback signal/service plug with Belimo PC-Tool
Connection:	Terminals 2.5 mm ²
Dimensions:	170 x 98 x 58 mm
Weight:	approx. 340 g
Maintenance:	maintenance-free

Volumetric flow controller VRAR

Alternative electric controller

VRU-M1R-BAC (make Belimo)

Self-adapting digital room pressure controller, with integrated static pressure sensor. Position-independent as a communication-capable universal solution with external actuators.

Measuring principle:	static differential pressure measurement
Measuring range sensor:	-75... ~75 Pa (bursting pressure +/- 10 kPa)
Sensor functional range:	-75... ~75 Pa
Supply voltage:	AC 24 V, 50/60 Hz, DC 24 V
Functional range:	AC 19...29 V / DC 19...29 V
Power consumption:	1.5 W (without actuator)
Dimensioning:	2 VA (with VST actuator)
Control function :	room pressure, stand-alone operation; positive control; parallel circuit
Setting range: P_{min} to P_{max} (pressure)	$P_{min} = 0...100\%$ of P_{nom} $P_{max} = 20...100\%$ of P_{nom} $P_{kon.} = 0...100\%$ of P_{nom}
Bus function:	BACnet MS/TP, Modbus RTU, MP bus
Command variable Y/Z: (inherent resistance min. 100 k Ω)	DC 0-10 V DC 2-10 V variable
Setting range: (actual value signal U)	DC 0-10 V DC 2-10 V variable
Sensor integration:	passive or active sensors (0-10V) for example, humidity, temperature 2-point signal (switching power 16 mA @ 24 V), for example switch, motion detector
Protection class:	III Safety extra-low voltage (SELV)
Degree of protection:	IP42 (measuring hoses and actuator connected)
Ambient temperature:	0 °C to +50 °C (environment), 5-95% relative humidity, non-condensing
Storage temperature:	-20 °C to +80 °C, 5-95% relative humidity, non-condensing
Operation and service:	via the ZTH EU setting device, Belimo Assistant app (NFC, Bluetooth) or via feedback signal/service plug with Belimo PC-Tool
Connection:	Terminals 2.5 mm ²
Dimensions:	170 x 98 x 58 mm
Weight:	approx. 340 g
Maintenance:	maintenance-free

GUAC-SM3/SCH (make Gruner)

Digital VAV controller, with static pressure sensor, position-independent als communication-capable universal solution.

Measuring principle:	static differential pressure measurement
Measuring range sensor:	0...~300 Pa (bursting pressure 1 bar)
Supply voltage:	AC 24 V, 50/60 Hz, DC 24 V
Functional range:	AC 19...29 V / DC 19...29 V
Power consumption:	0.5 W (without actuator)
Dimensioning:	1.5 VA (without actuator)
Control function:	VAV/CAV; Supply/return air or stand-alone operation; master/slave or parallel circuit
Setting range V_{min} to V_{max} :	$V_{min} = 0...100\%$ of V_{nom} $V_{max} = 0...100\%$ of V_{nom} $V_{konst.} = 0...100\%$ of V_{nom}
Command variable Y/Z: (Inherent resistance at least 100 k Ω)	DC 0-10 V (0-20 mA at least 500 Ω input resistance) DC 2-10 V (4-20 mA at least 500 Ω input resistance)
Setting range (actual value signal U/PP):	DC 0-10 V DC 2-10 V
DCC controller:	DCC controller or PLC
Sensor integration:	passive or active sensors (0-10V) for example, humidity, temperature 2-point signal (switching power 16 mA @ 24 V), for example switch, motion detector
Protection class:	III (Safety extra low voltage)
Degree of protection:	IP54 (measuring hoses connected)
Measuring air and ambient temp.:	0 °C to +70 °C (medium) 0 °C to +50 °C (environment), 5-95% relative humidity, non-condensing
Storage temperature:	-20 °C to +80 °C
Sound power level:	<35 dB(A)
Operation and service:	on the display, using a screwdriver directly at the device or via feedback signal/service plug using PC software
Connection:	cable 1000 mm, 4 x 0.75 mm ² (halogen-free), terminals
Dimensions:	124 x 71.5 x 66.5 mm
Weight:	approx. 175 g
Maintenance:	maintenance-free

Volumetric flow controller VRAR

Alternative electric controller

327VM-024-05-MB (-10, -15) (make Gruner)

Dynamic pressure sensor, digital VAV controller as a communication-capable VAV-Compact solution.

Measuring principle:	Pressure reading with volumetric flow
Measuring range sensor:	0... ~500 Pa (bursting pressure 1 bar)
Supply voltage:	AC 24 V, 50/60 Hz, DC 24 V
Functional range:	AC 19...29 V / DC 19...29 V
Power consumption:	2.5 W (5 Nm)
Dimensioning:	4.0 VA (5 Nm)
Torque:	min. 5 Nm at the rated voltage (10 Nm, 15 Nm, optional)
Control function:	VAV/CAV/Open-Loop; supply/return air or stand-alone operation; master/slave parallel circuit; Mixing box control
Setting range V_{min} to V_{max} :	$V_{min} = 0...100\%$ of V_{nom} $V_{max} = 0...100\%$ of V_{nom} $V_{konst.} = 0...100\%$ of V_{nom}
Command variable Y/Z: (Inherent resistance at least 100 k Ω)	DC 0-10 V (0-20 mA at least 500 Ω input resistance) DC 2-10 V (4-20 mA at least 500 Ω input resistance)
Setting range: (actual value signal U/PP)	DC 0-10 V DC 2-10 V
Bus function:	PP bus (open PP protocol) Modbus RTU, hybrid mode
DCC controller:	DCC controller or PLC
Sensor integration:	passive or active sensors (0-10V) for example, humidity, temperature 2-point signal (switching power 16 mA @ 24 V), for example switch, motion detector
Protection class:	III (Safety extra low voltage)
Degree of protection:	IP54 (measuring hoses connected)
Measuring air and ambient temp.:	0 °C to +70 °C (medium) 0 °C to +50 °C (environment) 5-95% relative humidity, non-condensing
Storage temperature:	-20 °C to +80 °C
Sound power level:	<35 dB(A)
Operation and service:	plug-in via diagnostic plug to PC-Tool GUIV, manual setting device or feedback signal.
Communication:	Modbus RTU
Connection:	cable 1000 mm, 4 x 0.75 mm ² (halogen-free), terminals
Dimensions:	115 x 65 x 61 mm
Weight:	approx. 550 g
Maintenance:	maintenance-free

327VM-024-05-DS4-MB (-10, -15) (make Gruner)

Static pressure sensor, digital VAV and pressure controller as a communication-capable VAV-Compact solution.

Measuring principle:	static pressure measurement (position-independent)
Measuring range sensor:	0... ~300 Pa (bursting pressure 1 bar)
Supply voltage:	AC 24 V, 50/60 Hz, DC 24 V
Functional range:	AC 19...29 V / DC 19...29 V
Power consumption:	2.5 W (5 Nm)
Dimensioning:	4.0 VA (5 Nm)
Torque:	min. 5 Nm at the rated voltage (10 Nm, 15 Nm, optional)
Control function:	VAV/CAV/Open-Loop; pressure control, supply/return air or stand-alone operation; master/slave parallel circuit; mixing box control
Setting range V_{min} to V_{max} :	$V_{min} = 0...100\%$ of V_{nom} $V_{max} = 0...100\%$ of V_{nom} $V_{konst.} = 0...100\%$ of V_{nom}
Command variable Y/Z: (Inherent resistance at least 100 k Ω)	DC 0-10 V (0-20 mA at least 500 Ω input resistance) DC 2-10 V (4-20 mA at least 500 Ω input resistance)
Setting range: (actual value signal U/PP)	DC 0-10 V DC 2-10 V
Bus function:	Modbus RTU, hybrid mode
DCC controller:	DCC controller or PLC
Sensor integration:	passive or active sensors (0-10V) for example, humidity, temperature 2-point signal (switching power 16 mA @ 24 V), for example switch, motion detector
Protection class:	III (Safety extra low voltage)
Degree of protection:	IP54 (measuring hoses connected)
Measuring air and ambient temp.:	0 °C to +70 °C (medium) 0 °C to +50 °C (environment) 5-95% relative humidity, non-condensing
Storage temperature:	-20 °C to +80 °C
Sound power level:	<35 dB(A)
Operation and service:	Using the display by means of a screwdriver directly at the device or via the feedback signal.
Communication:	Modbus RTU
Connection:	cable 1000 mm, 4 x 0.75 mm ² (halogen-free), terminals
Dimensions:	115 x 65 x 61 mm
Weight:	approx. 550 g
Maintenance:	maintenance-free

Volumetric flow controller VRAR

Alternative electric controller

327V-024-05-DS6-MB (-10, -15) (make Gruner)

Static pressure sensor, digital pressure controller as a communication-capable compact solution.

Measuring principle:	static pressure measurement (position-independent)
Measuring range sensor:	0... ~600 Pa (bursting pressure 1 bar)
Supply voltage:	AC 24 V, 50/60 Hz, DC 24 V
Functional range:	AC 19...29 V / DC 19...29 V
Power consumption:	2.5 W (5 Nm)
Dimensioning:	4.0 VA (5 Nm)
Torque:	min. 5 Nm at the rated voltage (10 Nm, 15 Nm, optional)
Control function:	pressure control, open loop; supply/return air or stand-alone operation; master/slave parallel circuit;
Setting range P_{min} to P_{max} :	$P_{min} = 0...100\%$ of P_{nom} $P_{max} = 0...100\%$ of P_{nom} $P_{konst.} = 0...100\%$ of P_{nom}
Command variable Y/Z: (Inherent resistance at least 100 k Ω)	DC 0-10 V (0-20 mA at least 500 Ω input resistance) DC 2-10 V (4-20 mA at least 500 Ω input resistance)
Setting range: (actual value signal U/PP)	DC 0-10 V DC 2-10 V
Bus function:	Modbus RTU, hybrid mode
DCC controller:	DCC controller or PLC
Sensor integration:	passive or active sensors (0-10V) for example, humidity, temperature 2-point signal (switching power 16 mA @ 24 V), for example switch, motion detector
Protection class:	III (Safety extra low voltage)
Degree of protection:	IP54 (measuring hoses connected)
Measuring air and ambient temp.:	0 °C to +70 °C (medium) 0 °C to +50 °C (environment) 5-95% relative humidity, non-condensing
Storage temperature:	-20 °C to +80 °C
Sound power level:	<35 dB(A)
Operation and service:	plug-in via diagnostic plug to PC-Tool GUIV, manual setting device or feedback signal
Communication:	Modbus RTU
Connection:	cable 1000 mm, 4 x 0.75 mm ² (halogen-free), terminals
Dimensions:	115 x 65 x 61 mm
Weight:	approx. 550 g
Maintenance:	maintenance-free

GLB181.1 E/3 (make Siemens)

Digital VAV controller, with dynamic pressure sensor and integrated actuator, position-independent as a communication-capable VAV-Compact solution.

Measuring principle:	Pressure sensor for dynamic measurement of the effective pressure, automatic zero point calibration
Measuring range sensor:	0... ~500 Pa measuring range, 0... ~300 Pa operating range (bursting pressure 1 bar)
Supply voltage:	AC 24 V, 50/60 Hz, DC 24 V, $\pm 20\%$
Functional range:	AC 19...29 V / DC 19...29 V
Torque:	min. 10 Nm at the rated voltage
Power consumption:	5.5 W (drive rotating) 0.5 W (stopping state)
Dimensioning:	7.5 VA (drive rotating) 1.0 VA (stopping state)
Control function:	VAV/CAV, open loop, Supply/return air or stand-alone operation; positive control; master/slave or parallel circuit
Setting range V_{min}/V_{max} :	$V_{min} = -20...100\%$ of V_{nom} $V_{max} = 20...100\%$ of V_{nom}
Setting range Command variable YC:	DC 0-10 V DC 2-10 V
Setting range Actual value signal U:	DC 0-10 V DC 2-10 V
Running time:	150 sec. for 90° angle of rotation
DCC controller:	DCC controller or PLC
Sensor integration:	passive or active sensors (0-10V)
Protection class:	III (Safety extra low voltage)
Degree of protection:	IP54 (measuring hoses connected)
Measuring air and ambient temperatures:	0 °C to +50 °C, 5-95% relative humidity, non-condensing
Storage temperature:	-25 °C to +70 °C
Operation and service:	via service socket with PC software ACS941 or AST 10 manual setting device
Connection:	cable 900 mm, 6 x 0.75 mm ² (halogen-free)
Dimensions:	158 x 71 x 61 mm
Weight:	approx. 600 g
Maintenance:	maintenance-free

Volumetric flow controller VRAR

Alternative electric controller

GDB181.1E/KN (make Siemens)

Digital VAV controller, with dynamic pressure sensor and integrated actuator, position-independent as a communication-capable VAV-Compact solution with KNX.

Measuring principle:	Pressure sensor for dynamic measurement of the effective pressure, automatic zero point calibration
Measuring range sensor:	0...~500 Pa measuring range, 0...~300 Pa operating range (bursting pressure 1 bar)
Supply voltage:	AC 24 V, 50/60 Hz, DC 24 V, $\pm 20\%$
Functional range:	AC 19...29 V / DC 19...29 V
Torque:	min. 5 Nm at the rated voltage
Power consumption:	2.5 W (drive rotating) 0.5 W (stopping state)
Dimensioning:	3.0 VA (drive rotating) 1.0 VA (stopping state)
Control function:	VAV/CAV, open loop, Supply/return air or stand-alone operation; positive control;
Setting range V_{\min}/V_{\max} :	$V_{\min} = -20...100\%$ of V_{nom} $V_{\max} = 20...100\%$ of V_{nom}
Setting range Command variable YC:	KNX bus
Setting range Actual value signal U:	KNX bus
Running time:	150 sec. for 90° angle of rotation
Protection class:	III (Safety extra low voltage)
Degree of protection:	IP54 (measuring hoses connected)
Measuring air and ambient temperatures:	0 °C to +50 °C (medium), 0 °C to +50 °C (environment), 5-95% relative humidity, non-condensing
Storage temperature:	-25 °C to +70 °C
Operation and service:	via service socket with PC software ACS941 or AST 10 manual setting device
Connection:	cable 900 mm, 2 x 2 x 0.75 mm ² (halogen-free)
Dimensions:	158 x 71 x 61 mm
Weight:	approx. 600 g
Maintenance:	maintenance-free

GLB181.1E/KN (make Siemens)

Digital VAV controller, with dynamic pressure sensor and integrated actuator, position-independent as a communication-capable VAV-Compact solution with KNX.

Measuring principle:	Pressure sensor for dynamic measurement of the effective pressure, automatic zero point calibration
Measuring range sensor:	0...~500 Pa measuring range, 0...~300 Pa operating range (bursting pressure 1 bar)
Supply voltage:	AC 24 V, 50/60 Hz, DC 24 V, $\pm 20\%$
Functional range:	AC 19...29 V / DC 19...29 V
Torque:	min. 10 Nm at the rated voltage
Power consumption:	5.5 W (drive rotating) 0.5 W (stopping state)
Dimensioning:	7.5 VA (drive rotating) 1.0 VA (stopping state)
Control function:	VAV/CAV, open loop, Supply/return air or stand-alone operation; positive control;
Setting range V_{\min}/V_{\max} :	$V_{\min} = -20...100\%$ of V_{nom} $V_{\max} = 20...100\%$ of V_{nom}
Setting range Command variable YC:	KNX bus
Setting range Actual value signal U:	KNX bus
Running time:	150 sec. for 90° angle of rotation
Protection class:	III (Safety extra low voltage)
Degree of protection:	IP54 (measuring hoses connected)
Measuring air and ambient temperatures:	0 °C to +50 °C (medium), 0 °C to +50 °C (environment), 5-95% relative humidity, non-condensing
Storage temperature:	-25 °C to +70 °C
Operation and service:	via service socket with PC software ACS941 or AST 10 manual setting device
Connection:	cable 900 mm, 2 x 2 x 0.75 mm ² (halogen-free)
Dimensions:	158 x 71 x 61 mm
Weight:	approx. 600 g
Maintenance:	maintenance-free

Volumetric flow controller VRAR

Alternative electric controller

DVC-V322A / DVC-V322AF (make Delta Controls)

Freely programmable Advanced Application Controller (B-AAC), with static pressure sensor and actuator, as a communication-capable VAV-Compact solution.

Measuring principle:	Pressure sensor for static effective pressure measurement
Measuring range sensor:	2... ~ 250 Pa operating range (bursting pressure 1 bar)
Supply voltage:	AC 24 V, 50 Hz, $\pm 20\%$
Functional range:	AC 19...29 V / DC 19...29 V
Power consumption:	2.5 W (drive rotating)
Dimensioning:	15 VA (32 VA with fully loaded TRIAC outputs)
Torque:	min. 5 Nm at the rated voltage
Control function:	VAV/CAV; Supply/return air or stand-alone operation; Positive control
Setting range V_{\min} to V_{\max} :	$V_{\min} = 0...100\%$ of V_{nom} $V_{\max} = 20...100\%$ of V_{nom}
Running time:	150 sec. for 90° angle of rotation
Inputs:	2 Universal inputs, 10-bit resolution (0-5 V, 0-10 V, 10 K Ω ., 4-20 mA, potential-free contacts) 1 input 10-bit resolution (10 K Ω , potential-free contacts)
Outputs:	2 binary TRIAC outputs 2 analogue outputs (0-10 V DC, 8 bit) LED status display for each output
Protection class:	III (Safety extra low voltage)
Measuring air and ambient temperatures:	0 °C to +50 °C, 10-90% relative humidity, non-condensing
Storage temperature:	-25 °C to +70 °C
Sound power level:	max. 35 dB (A)
Operation and service:	via service socket with PC software
Communications connections:	RS-485 Main LAN (NET1) BACnet MS/TP @ 9600, 19200, 38400 or 76800 bps (standard) a maximum of 99 devices per BACnet MS/TP Subnet segment RS-485 Sub LAN (NET2) Delta LINKnet @ 76800 bps a maximum of 4 devices on the LINKnet with no more than 2 DFM/DNT devices
Dimensions:	239 x 120 x 80 mm
Weight:	approx. 840 g
Maintenance:	maintenance-free

Standard pneumatic controller

RLP100 F003 (make Sauter)

Pneumatic integral volumetric flow controller in connection with a damper drive with control flap and a measuring sensor for use with fixed, switchover and variable control

Measuring principle:	High-precision, static differential pressure sensor
Measuring range sensor:	1...160 Pa
Feed pressure:	1.3 bar +/- 0.1 bar
Air consumption:	44 l/h
Air flow pressure:	0.2...1.0 bar
Response sensitivity:	0.1 Pa
Allowed ambient temperature:	0 °C to +55 °C
Degree of protection:	IP 30
Control direction:	Depressurised CLOSED/OPEN (B/A)
Conforms to EN 13463-1 and EN 1127-1 (Ex II 2 G T6) and for use in potentially explosive atmospheres of Zone 1.	

For supply and return air (integral room air control system)

Alternative pneumatic controller

RLP100 F914 (make Sauter)

Pneumatic integral volumetric flow controller in connection with a damper drive with control flap and a measuring sensor for use with fixed, switchover and variable control Can be used if air

Measuring principle:	High-precision, static differential pressure sensor
Measuring range sensor:	1...160 Pa
Feed pressure:	1.3 bar +/- 0.1 bar
Air consumption:	44 l/h
Air flow pressure:	0.2...1.0 bar
Response sensitivity:	0.1 Pa
Allowed ambient temperature:	0 °C to +55 °C
Degree of protection:	IP 30
Control direction:	Depressurised OPEN (A)
Conforms to EN 13463-1 and EN 1127-1 (Ex II 2 G T6) and for use in potentially explosive atmospheres of Zone 1.	

contains aggressive media.

For return air with aggressive gases (integral room air control system)

Volumetric flow controller VRAR

Damper actuators ...24A-VST (make BELIMO)
for VRU-...-BAC

LM24A-VST

Actuator, communicative, with position feedback

Supply voltage:	AC 24 V, 50/60 Hz, DC 24 V, ready to plug in
Functional range:	AC 19.2-28.8 V / DC 21.6-28.8 V
Power consumption:	1 W (during operation)
Dimensioning:	2 VA
Torque:	5 Nm (at the rated voltage)
Running time for 90° (or 95°):	120 sec.
Activation:	communicative PP
Protection class:	III Safety extra-low voltage (SELV)
Degree of protection:	IP 54
Ambient temperature:	-30 °C to +50 °C, 5-95% relative humidity, non-condensing
Storage temperature:	-40 °C to +80 °C
Sound power level:	max. 35 dB(A)
Manual adjustment:	Gears are disengaged by pushbutton, self-restoring
Connection:	cable 500 mm with VST plug
Dimensions:	116 x 66 x 61 mm
Weight:	approx. 560 g
Maintenance:	maintenance-free

NM24A-VST

Actuator, communicative, with position feedback

Supply voltage:	AC 24 V, 50/60 Hz, DC 24 V, ready to plug in
Functional range:	AC 19.2-28.8 V / DC 21.6-28.8 V
Power consumption:	2 W (during operation)
Dimensioning:	4 VA
Torque:	10 Nm (at the rated voltage)
Running time for 90° (or 95°):	120 sec.
Activation:	communicative PP
Protection class:	III Safety extra-low voltage (SELV)
Degree of protection:	IP 54
Ambient temperature:	-30 °C to +50 °C, 5-95% relative humidity, non-condensing
Storage temperature:	-40 °C to +80 °C
Sound power level:	max. 35 dB(A)
Manual adjustment:	Gears are disengaged by pushbutton, self-restoring
Connection:	cable 500 mm with VST plug
Dimensions:	124 x 80 x 62 mm
Weight:	approx. 780 g
Maintenance:	maintenance-free

NF24A-VST

Spring return actuator with emergency control function, communicative, with position feedback.

Supply voltage:	AC 24 V, 50/60 Hz, DC 24 V, ready to plug in
Functional range:	AC 19.2-28.8 V / DC 21.6-28.8 V
Power consumption:	5 W (in motion)
Dimensioning:	8 VA
Torque:	10 Nm (at the rated voltage)
Spring torque:	10 Nm
Running time for 90°:	120 sec. (motor) < 20 sec. (spring)
Activation:	communicative PP
Protection class:	III Safety extra-low voltage (SELV)
Degree of protection:	IP54
Ambient temperature:	-30 °C to +50 °C, 5-95% relative humidity, non-condensing
Storage temperature:	-40 °C to +80 °C
Sound power level:	max. 40 dB(A) (motor)
Manual adjustment:	Manual winding with lock
Connection:	cable 500 mm with VST plug
Dimensions:	214 x 98 x 93 mm
Weight:	approx. 2300 g
Maintenance:	maintenance-free

NMQ24A-VST

High-speed actuator, communicative, with position feedback

Supply voltage:	AC 24 V, 50/60 Hz, DC 24 V, ready to plug in
Functional range:	AC 19.2-28.8 V / DC 21.6-28.8 V
Power consumption:	13 W (during operation)
Dimensioning:	23 VA
Torque:	8 Nm (at the rated voltage)
Running time for 90°:	4 sec.
Activation:	communicative PP
Protection class:	III Safety extra-low voltage (SELV)
Degree of protection:	IP 54
Ambient temperature:	-30 °C to +50 °C, 5-95% relative humidity, non-condensing
Storage temperature:	-40 °C to +80 °C
Sound power level:	max. 56 dB(A)
Manual adjustment:	Gears are disengaged by pushbutton, self-restoring
Connection:	cable 500 mm with VST plug
Dimensions:	139 x 88 x 77 mm
Weight:	approx. 780 g
Maintenance:	maintenance-free

Volumetric flow controller VRAR

NKQ24A-VST

High-speed actuator with emergency control function, communicative, with position feedback

Supply voltage:	AC 24 V, 50/60 Hz, DC 24 V, ready to plug in
Functional range:	AC 19.2-28.8 V / DC 21.6-28.8 V
Power consumption:	11 W (during operation)
Dimensioning:	22 VA
Torque:	6 Nm (at the rated voltage)
Running time for 90°:	4 sec. (motor) 4 sec. (emergency control)
Emergency position setting	0...100% in 10% steps
Precharge time:	approx. 15 sec.
Activation:	communicative PP
Protection class:	III Safety extra-low voltage (SELV)
Degree of protection:	IP 54
Ambient temperature:	-30 °C to +50 °C, 5-95% relative humidity, non-condensing
Storage temperature:	-40 °C to +80 °C
Sound power level:	max. 60 dB(A)
Manual adjustment:	Gears are disengaged by pushbutton, self-restoring
Connection:	cable 500 mm with VST plug
Dimensions:	139 x 88 x 80 mm
Weight:	approx. 1400 g
Maintenance:	maintenance-free

LMQ24A-VST

High-speed actuator, communicative, with position feedback

Supply voltage:	AC 24 V, 50/60 Hz, DC 24 V, ready to plug in
Functional range	AC 19.2-28.8 V / DC 21.6-28.8 V
Power consumption:	13 W (during operation)
Dimensioning:	23 VA
Torque:	4 Nm (at the rated voltage)
Running time for 90°:	2.5 sec.
Activation:	communicative PP
Protection class:	III Safety extra-low voltage (SELV)
Degree of protection:	IP 54
Ambient temperature:	-30 °C to +50 °C, 5-95% relative humidity, non-condensing
Storage temperature:	-40 °C to +80 °C
Sound power level:	max. 54 dB(A)
Manual adjustment:	Gears are disengaged by pushbutton, self-restoring
Connection:	cable 500 mm with VST plug
Dimensions:	124 x 80 x 75 mm
Weight:	approx. 560 g
Maintenance:	maintenance-free

Volumetric flow controller VRAR

Damper drives...24- (make Gruner)
for **GUAC-SM3/SCH**

341C-024-05-V

Spring return actuator, ready to be plugged in for GUAC-...

Supply voltage:	AC 24 V, 50/60 Hz, DC 24 V
Functional range:	AC 19...29 V / DC 19...29 V
Power consumption:	5 W (in motion)
Dimensioning:	6.5 VA
Torque:	> 5 Nm (at the rated voltage)
Spring torque:	>5 Nm
Running time for 90°:	< 100 sec. (motor) < 20 sec. (spring)
Activation:	6 ± 4 V DC (from GUAC)
Protection class:	III (safety extra low voltage)
Degree of protection:	IP 54
Ambient temperature:	-30 °C to +50 °C, 5-95% relative humidity, non-condensing
Storage temperature:	-30 °C to +80 °C
Sound power level:	< 35 dB(A) (motor) < 65 dB(A) (spring)
Manual adjustment:	Manual winding with lock
Connection:	Cable 1000mm with Phönix plug
Dimensions:	145 x 75 x 70 mm
Weight:	approx. 1200 g
Maintenance:	maintenance-free

361C-024-10-V

Spring return actuator, ready to be plugged in for GUAC-...

Supply voltage:	AC 24 V, 50/60 Hz, DC 24 V
Functional range:	AC 19...29 V / DC 19...29 V
Power consumption:	5 W (in motion)
Dimensioning:	8 VA
Torque:	> 10 Nm (at the rated voltage)
Spring torque:	> 10 Nm
Running time for 90°:	< 150 sec. (motor) < 20 sec. (spring)
Activation:	6 ± 4 V DC (from GUAC)
Protection class:	III (safety extra low voltage)
Degree of protection:	IP 54
Ambient temperature:	-30 °C to +50 °C, 5-95% relative humidity, non-condensing
Storage temperature:	-30 °C to +80 °C
Sound power level:	< 35 dB(A) (motor) < 65 dB(A) (spring)
Manual adjustment:	Manual winding with lock
Connection:	Cable 1000mm with Phönix plug
Dimensions:	193 x 96 x 60 mm
Weight:	approx. 1,800 g
Maintenance:	maintenance-free

328CS-024-05B-V

High-speed drive, ready to be plugged in for GUAC-... with position feedback

Supply voltage:	AC 24 V, 50/60 Hz, DC 24 V
Functional range:	AC 19...29 V / DC 19...29 V
Power consumption:	11 W (in motion)
Dimensioning:	15 VA
Torque:	> 5 Nm (at the rated voltage)
Running time for 90°:	2 sec.
Activation:	6 ± 4 V DC (from GUAC)
Protection class:	III (safety extra low voltage)
Degree of protection:	IP 54
Ambient temperature:	-30 °C to +50 °C, 5-95% relative humidity, non-condensing
Storage temperature:	-30 °C to +80 °C
Sound power level:	< 55 dB(A)
Manual adjustment:	Gears are disengaged by pushbutton, self-restoring
Connection:	Cable 1000mm with Phönix plug
Dimensions:	172.5 x 65 x 90 mm
Weight:	approx. 790 g
Maintenance:	maintenance-free

328CS-024-10B-V

High-speed drive, ready to be plugged in for GUAC-... with position feedback

Supply voltage:	AC 24 V, 50/60 Hz, DC 24 V
Functional range:	AC 19...29 V / DC 19...29 V
Power consumption:	18 W (in motion)
Dimensioning:	22 VA
Torque:	> 10 Nm (at the rated voltage)
Running time for 90°:	3 sec.
Activation:	6 ± 4 V DC (from GUAC)
Protection class:	III (safety extra low voltage)
Degree of protection:	IP 54
Ambient temperature:	-30 °C to +50 °C, 5-95% relative humidity, non-condensing
Storage temperature:	-30 °C to +80 °C
Sound power level:	< 55 dB(A)
Manual adjustment:	Gears are disengaged by pushbutton, self-restoring
Connection:	Cable 1000mm with Phönix plug
Dimensions:	172.5 x 65 x 90 mm
Weight:	approx. 790 g
Maintenance:	maintenance-free

Volumetric flow controller VRAR

Functional check

NMV-D3-MP and LMV-D3-MP:

Functional check

Electrical connection

Apply supply voltage 24 V AC ($\pm 10\%$) to terminals 1+2.

Is the polarity of system neutral conductor correct?

⇒ **No:** Check the wiring according to the diagram. Check transformer power.

→ NMV-D3-MP 5.5 VA / LMV-D3-MP 5 VA

⇒ **Yes:** **NMV-D3-MP / ZTH EU or LMV-D3-MP / ZTH EU**

⇓

NMV-D3-MP / ZTH EU or LMV-D3-MP / ZTH EU:

Has the NMV-D3-MP / LMV-D3-MP been set to the correct operating mode?

(Check using the connected setting device ZTH EU!)

⇒ **No:** Set operating mode using ZTH EU.

→ Operating modes: 0-10 V, 2-10 V

⇒ **Yes:** **Drive**

⇓

Drive:

Use the ZTH-EU to set operating mode 2-10 V and connect terminals 1+3 of the NMW-D3-MP / LMV-D3-MP.

Does the drive move to the "CLOSED" position?

⇒ **No:** Contact VRA manufacturer.

⇒ **Yes:** V_{\max}

⇓

V_{\max} :

Connect the terminals 2+3 of the NMV-D3-MP / LMV-D3-MP.

Does the NMV-D3-MP / LMV-D3-MP control to V_{\max} ? - Check actual value signal U_5 .

⇒ **No:** Check V_{\max} value in the ZTH EU and compare settings with the technical data on the VAV machine.

→ If the drive moves to the "OPEN" position, and the maximum volume is not reached, then the duct pressure is too low.

⇒ **Yes:** Use ZTH EU to set the system-specific operating mode.

Functional check during startup and service

If required, easily accessible setting potentiometers and connections allow set values and the correct operation of the volumetric flow controllers to be reliably and quickly checked on-site.

Volumetric flow controller VRAR

Startup using PC-Tool

Direct connection in the switch cabinet or socket
(traditional application)

ZTH EU as MP level converter



Description

The ZTH EU is also a potential-free interface between the USB port of a PC and the Belimo MP bus. It is used to connect the Belimo PC-Tool directly to the MP bus or directly to a programmable MFT drive.

Power supply

The ZTH EU is supplied with power by the USB port. The MP bus voltage is obtained internally by means of DC/DC converter. This is why no external power supply is necessary.

Driver

To be able to work with the ZTH EU, a suitable driver must be installed on the PC. The driver can be downloaded from the Belimo website (download section). After installation of the driver, the ZTH EU device will log in to the PC as a virtual COM interface.

Note

For connection to USB ports of PCs and BELIMO 24 V drives only (to safety extra low voltage SELV or US class 2 feeds).

Connection diagram 1

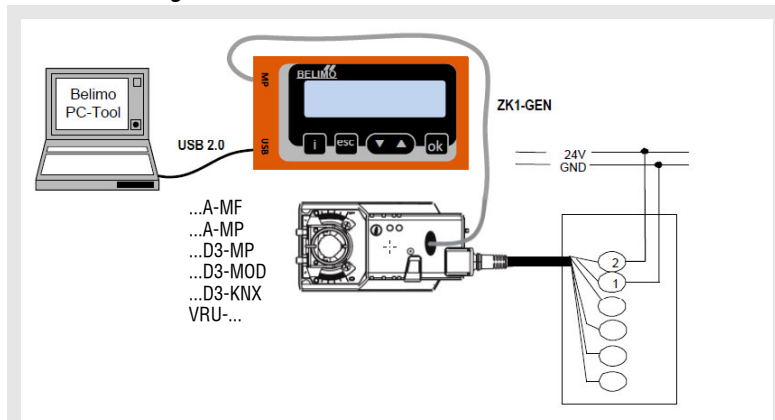

Local connection via a service socket of the MF/MP or LON drive using a ZK1-GEN cable.

Connection diagram 2

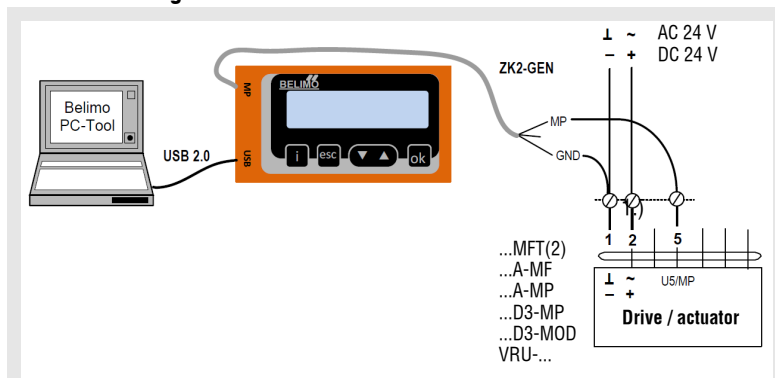

Local connection via a connecting cable of the MF/MP or LON drive using a ZK2-GEN cable.

- 1.) white = GND
- green = MP
- blue = not connected

Volumetric flow controller VRAR

Startup using the setting and diagnostic device ZTH EU (Belimo)



Brief description

The VAV setting device ZTH EU allows efficient testing of VAV and CAV installations. Installations fitted with the Belimo VAV controller can be simply adapted to the room and user requirements.

The VAV setting device ZTH EU replaces the previous setting device ZTH-GEN (2007-2014).

All standard Belimo VAV controllers with integrated PP communication (from 1992) that are sold in the EU can be set using the ZTH EU.

Specifications:

- easy, quick setting of the VAV boxes parameters
- diagnostic function
- one tool for all VAV units
- voltage supplied by VAV controllers - no batteries required!
- service socket VAV / CR24 controller, PP connection
- includes connecting cable RJ12 6/4, 6-pin plug
- New generation, MP bus tester
- for functional test of MP bus
- backward compatible with all Belimo PP / MP units from 1992
- efficient handling, can be operated with one hand
- Selection of stages for test (OPEN/CLOSE/MIN/MAX/STOP)
- Damper position indicator for diagnostics
- Display of the setpoint / actual volume and $V_{min/max}$ setting in m^3/s (l/s).

Operating element:

LCD display:

- Backlight
- Display with 2 x 16 digits



Key function:

- ▲▼ Forwards / backwards, change value / status
- ok Confirm input / switch to the submenu
- esc Cancel input / Leave submenu / Discard changes
- i shows additional information (if available)

Connection:

Locally via service socket



Dimensions:

85x65x23 (WxHxD)

Connection and supply

Stand-alone operation:

Connection including supply takes place via the service socket at the VAV controller or via the terminals.

Bus operation:

The ZTH EU can be used in the following units while the bus is running if it is connected via the local service socket: L/NMV-D3-MP.

With the VRP-M and L/NMV-D3M, the MP-Bus must be disconnected when the service socket is used.

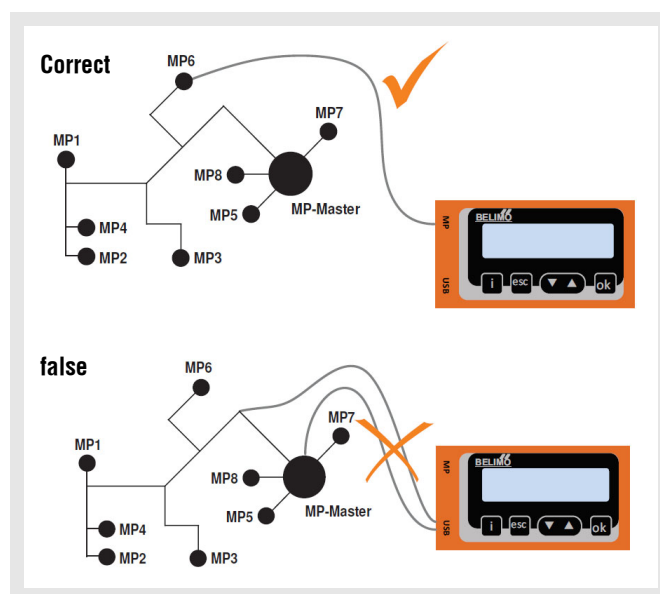

Restriction:

Direct connection in an MP network or via an MP-Bus master is not possible.

The ZTH EU comes with a quick start guide de/en to be affixed to the back of the unit.

Volumetric flow controller VRAR

Smartphone - Belimo Assistant App

The NFC antenna area of the VAV Compact is located between the Belimo or OEM logo and the NFC label.

Align NFC-capable android smartphone with loaded Assistant app on the VAV-Compact such that the two antennae are above one another.

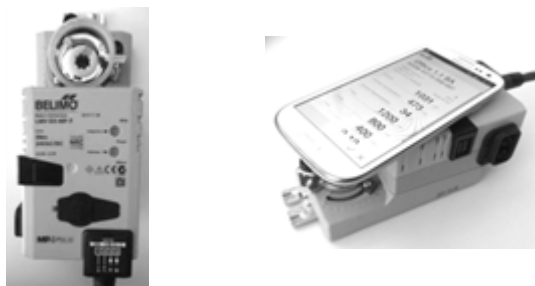

The Belimo Assistant app can be downloaded from the Google Play Store.

NFC-capable devices:

- L/NMV-D3-MP with printed NFC label
- VRU-...

Non-NFC-capable devices:

- All devices without NFC label
- L/NMV-D3-MF

Startup using the setting device GUIV-A

Application

The setting device GUIV-A is used by the startup or service personnel in order to carry out simple settings to the equipment or to check the actual values.

The controller type 227V does not have any operating elements such as switches or setpoint potentiometers. To program the operating modes and the operating parameters V_{\min} and V_{\max} , the setting device GUIV-A is required, which can also be used to switch from 2 - 10 V DC to 0 - 10 V DC.

Connection

The GUIV-A can be connected electrically to 227 V via the U/PP connection by direct on-site or remote control, for example in a switch cabinet.

Structure and operation

The relevant parameters can be set and queried in the individual menu items, while the operating parameters programmed in-factory can be queried under menu item 10.

Note:

As long as the U/PP connector is connected to the GUIV-A, the output signal U does not correspond to the actual value.

Connection diagram

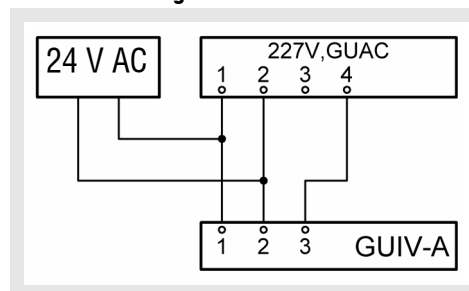

- 1 Earth, neutral
- 2 Supply voltage 24 V AC
- 3 Setpoint value signal Y and positive control Z input 227V, GUAC
- 4 Output communication signal PP and actual volumetric flow U

Volumetric flow controller VRAR

Differential pressure diagram

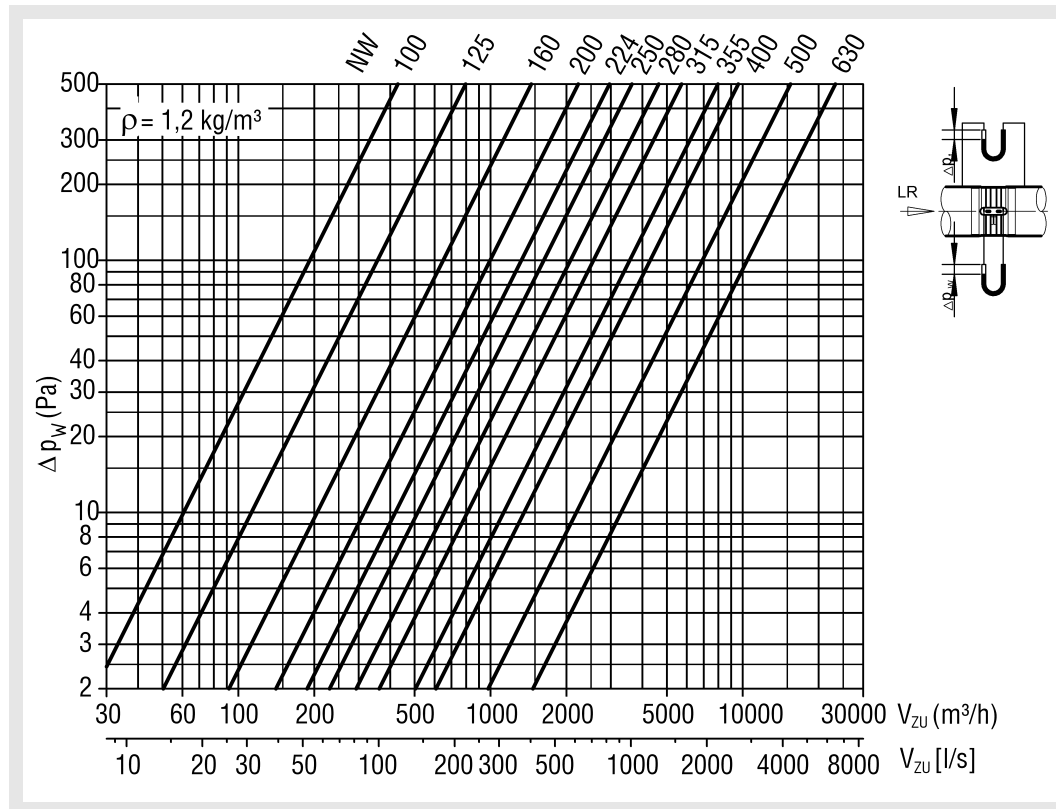

Volumetric flow controller VRAR

Controller selection

The selection of each actuator (torque) depends on the housing dimensions. The actuator is already selected and mounted at the factory.

Electric controller - standard				
Controller	Actuator	DM	AN	AG
- Belimo :				
- LMV-D3-MP-F1	Compact	1.)	-	-A001
- NMV-D3-MP-F1	Compact	2.)	-	-A002

Electric controller - alternative				
Controller	Actuator	NW	AN	AG
- Belimo :				
- VRU-D3-BAC	LM24A-VST	1.)	-	-A142
	NM24A-VST	2.)	-	-A143
	LMQ24A-VST	1.)	SL	-A145
	NMQ24A-VST	1.)	SL	-A146
	NKQ24A-VST	1.)+2.)	SL	-A147
	NF24A-VST	2.)	FR	-A148
- VRU-M1-BAC	LM24A-VST	1.)	-	-A150
	NM24A-VST	2.)	-	-A151
	LMQ24A-VST	1.)	SL	-A153
	NMQ24A-VST	2.)	SL	-A154
	NKQ24A-VST	1.)+2.)	SR	-A155
	NF24A-VST	2.)	FR	-A156
- VRU-M1R-BAC	LMQ24A-VST	1.)	SL	-A158
	NMQ24A-VST	2	SL	-A159
- Siemens :				
- GDB181.1E/3	Compact	1.)	-	-A076
- GLB181.1E/3	Compact	2.)	-	-A077
- GDB181.1E/KN	Compact	1.)	-	-A078
- GLB181.1E/KN	Compact	2.)	-	-A079
- Sauter :				
- ASV215BF132E	Compact	1.)+2.)	-	-A138
- ASV215BF152E	Compact	1.)+2.)	SL	-A139
- Delta Controls :				
- DVC-V322A	Siemens	1.)	-	-A087
- DVC-V322AF	Siemens	1.)	-	-A088
- Gruner :				
- GUAC-SM3/SCH	341C-024-05-V	1.)	FR	-A068
	361C-024-10-V	2.)	FR	-A069
	328CS-024-05B-V/ST06	1.)	SL	-A070
	328CS-024-10B-V/ST06	2.)	SL	-A071
- GUAC-PM3/SCH	341C-024-05-V	1.)	FR	-A072
	361C-024-10-V	2.)	FR	-A073
	328CS-024-05B-V/ST06	1.)	SL	-A074
	328CS-024-10B-V/ST06	2.)	SL	-A075
- GUAC-DM3/SCH	341C-024-05-V	1.)	FR	-A131
	361C-024-10-V	2.)	FR	-A132
	328CS-024-05B-V/ST06	1.)	SL	-A133
	328CS-024-10B-V/ST06	2.)	SL	-A134
- 327VM-24-05-MB	Compact	1.)	-	-A160
- 327VM-24-10-MB	Compact	2.)	-	-A161
- 327VM-24-05-DS4-MB	Compact	1.)	-	-A163
- 327VM-24-10-DS4-MB	Compact	2.)	-	-A164
- 327VM-24-05-DS6-MB	Compact	1.)	-	-A166
- 327VM-24-10-DS6-MB	Compact	2.)	-	-A167

Pneumatic controller - standard				
Controller	servo cylinder	NW	AN	AG
- Sauter :				
- RLP100 F003	AK31P1 F001	1.)	LA	-A106
	AK42P F003	2.)	LA	-A107

Pneumatic controller - alternative				
Controller	servo cylinder	NW	AN	AG
- Sauter :				
- RLP100 F914	AK31P1 F001	1.)	LA	-A108
	AK42P F003	2.)	LA	-A109

Accessories:

S1A/S2A, limit switch make Belimo, to fit all new compact controllers and actuators of make Belimo.

ZTH EU, PC-Tool and ZTH EU for Belimo LMV-D3-MP / AST20 for Siemens GLB 181.1 E/3 / WIN-VAV-2 for Gruner 327VM.

NW = Nominal value

AN = Actuator type

SL (High-speed damper drive)

SR (High-speed damper drive with return)

FR (Spring return)

LA (Linear drive)

- (standard)

AG = Attachment assembly

1.) = NW 100-400

2.) = NW 500-630

Volumetric flow controller VRAR

Maintenance and service

Assembly and maintenance instructions

1. When the device is delivered, check whether the controllers are complete and have been delivered without damage. Complaints have to be communicated immediately and directly to the transporter and SCHAKO.
2. The volumetric flow controller must not be carried on the regulation components, measuring cross or the damper leaf, but only on the housing.
3. The controllers must be carefully stored on-site. They must be protected from dust, dirt and from direct weather effects.
4. The controllers must be assembled in a way to allow inspection.
5. Assembly must be carried out by expert personnel, observing recognised technical rules and regulations.
6. For explosion-proof rooms, explosion-protected control components must be used.
7. **For polluted air, the volumetric flow controllers must be used with an integrated controller with a static pressure sensor. In this case, it is absolutely necessary to observe the mounting position. The volumetric flow controllers are not suitable for air containing sticky and greasy particles.**

Zero adjustment of the static pressure sensors VFP-...

The pressure probe is based on a static pressure meter. Great care must be taken to ensure correct transport and correct assembly. The volumetric flow controllers have been adjusted in-factory by the OEM manufacturer according to their mounting position. If the controllers are installed in another position the sensors can be adjusted as follows.

1. Sensor VFP-... must be installed.
2. Connect VFP-... to VRP and supply VRP with 24 V AC mains voltage.
3. Remove lid from VFP-... .
4. Move damper to the "OPEN" position.
5. Pull damper drive plug from the VRP.
6. Remove the pressure hoses from the connection spigots.
Attention! Make a note of the (+) and (-) assignments.
7. The membrane position is considered balanced when both LEDs are dark (OFF). If the meter position is not balanced, one of the two LEDs will light up, and the position must be adjusted on the potentiometer in the VFP-...
8. Slowly turn the zero point adjustment of the potentiometer (non-painted potentiometer), until both LEDs are dark (OFF).
9. Assemble lid of VFP-....
10. Reconnect pressure hoses, (+) and (-) as before.
11. Reconnect the plug of the damper drive.

Cleaning of the dynamic differential pressure sensor

The differential pressure sensor integrated in the **NMV-D3-MP**, **LMV-D3-MP** and **VRU-D3-BAC** requires little maintenance. However, if, depending on the degree of pollution of the air, unexpected volumetric flow deviations occur, then the following procedure is recommended.

1. Pull off the pressure hoses from the sensor connection spigot of the NMV-D3-MP, LMV-D3-MP or of the VRU-D3-BAC .
Attention! Make a note of the (+) and (-) assignments.
2. Using a suitable hand pump, blow air into the (+) or (-) spigot of the sensor (this will blow any dirt deposited inside the sensor out of the spigot).
3. Remove any dirt that may have formed from the spigots and hose ends.
4. Reconnect pressure hoses, (+) and (-) as before.
5. Carry out a functional check of the controller.

Legend

NW	(mm)	= Nominal width
P	(mm)	= Packing thickness
D_e	[dB/Okt]	= Insertion loss
f_m	(Hz)	= Octave band centre frequency
V	(m ³ /h) [l/s]	= Air volume
V_{ZU}	(m ³ /h) [l/s]	= Supply air volume
V_{min}	(m ³ /h) [l/s]	= Minimum volumetric flow
V_{max}	(m ³ /h) [l/s]	= Maximum volumetric flow
$V_{konstant}$	(m ³ /h) [l/s]	= constant volumetric flow
v_K	(m/s)	= Duct velocity
Δp	(Pa)	= Pressure difference
Δp_t	(Pa)	= Pressure loss
$\Delta p_{t\ min}$	(Pa)	= Minimum static pressure difference
Δp_W	(Pa)	= Differential pressure
ρ	(kg/m ³)	= Density
L_W	[dB/Okt]	= Sound power level / octave ($L_W = L_{W1} + KF$)
L_{W1}	[dB/Okt]	= Sound power level / octave relative to 1 m ² of inflow area
L_{WA}	[dB(A)]	= A-weighted sound power level ($L_{WA} = L_{WA1} + KF$)
L_{WA1}	[dB(A)]	= A-weighted sound power level in the duct relative to 1 m ² of inflow area
ΔL_W	[dB/Okt]	= Level correction value / octave
$L_W\ abst$	[dB/Okt]	= Radiated noise / octave
KF	(-)	= Correction factor
LR	(-)	= Air flow direction
EW	(%)	= Set value
EK	(m/s)	= Calibration curve
U_5	(V DC)	= U_5 signal
F	(m ²)	= Area
x		= available
--		= not available

Volumetric flow controller VRAR

Order code

01	02	03	04	05	06
Type	Nominal width	Material	Attachment assembly	Mode	Volumetric flow V_{\min}
Example					
VRAR	-125	-SV	-A001	-0	-00100

07	08	09	10
Volumetric flow V_{\max}	Duct connection	Acoustic cladding	Damper position
-00300	-GD1	-DS2	-NA

Sample

VRAR-125-SV-A001-0-00100-00300-GD1-DS2-NA

Volumetric flow controller type VRAR, round design | NW 125 | galvanised sheet steel | with LMV-D3-MP-F1 | mode 0-10 V | V_{\min} = 100 m³/h | V_{\max} = 300 m³/h | with rubber lip seal | with acoustic cladding 20 mm | no spring return actuator

ORDER DETAILS

01 - Type

VRAR = Volumetric flow controller VRAR, round design

02 - Nominal width

100 = NW 100
 125 = NW 125
 160 = NW 160
 200 = NW 200
 225 = NW 225
 250 = NW 250
 280 = NW 280
 315 = NW 315
 355 = NW 355
 400 = NW 400
 500 = NW 500
 630 = NW 630

03 - Material

SV = Galvanised sheet steel (standard)
 V2 = Stainless steel V2A, 1.4301
 V4 = Stainless steel V4A, 1.4571
 DD = DD-coating on the inside with galvanised sheet steel

04 - Attachment assembly

- with electric controller – standard:

A001 = LMV-D3-MP-F1, Compact (NW 100-400)
 A002 = NMV-D3-MP-F1, Compact (NW 500-630)

- with electric controller – alternative:

A142 = VRU-D3-BAC, LM24A-VST (NW 100-400)
 A143 = VRU-D3-BAC, NM24A-VST (NW 500-630)

other modules available upon request (see Controller selection table on page 49).

- with pneumatic controller – standard:

A106 = RLP100 F003, AK31P1 F001 (linear drive, NW 100-400)
 A107 = RLP100 F003, AK42P F003 (linear drive, NW 500-630)

- with pneumatic controller – alternative:

A108 = RLP100 F914, AK31P1 F001 (linear drive, NW 100-400)
 A109 = RLP100 F914, AK42P F003 (linear drive, NW 500-630)

05 - Mode

0 = 0-10 V
 2 = 2-10 V (standard) (Pneumatic controllers can only be delivered in mode 2!)

06 - Volumetric flow set value V_{\min}/V_{kon}

00000 = ex-works according to table
 xxxxx = 5-digit value in m³/h

07 - Volumetric flow set value V_{\max}

00000 = ex-works according to table
 xxxxx = 5-digit value in m³/h

Volumetric flow controller VRAR

08 - Duct connection

- KA0 = without rubber lip seal / without flange (standard)
- GD1 = with rubber lip seal
- FF1 = with flat flange (pair), on both sides, galvanised steel
- FF2 = with flat flange (pair), on both sides, stainless steel 1.4301 (V2A)
- MF1 = with Metu flange (pair), on both sides, galvanised sheet steel
- MF2 = with Metu flange (pair), on both sides, stainless steel 1.4301 (V2A)

Please note!

Tension rings, counter flanges and duct silencers must be ordered separately and are supplied loose!

09 - Acoustic cladding

- DS0 = without acoustic cladding (standard)
- DS2 = with acoustic cladding 20 mm
- FD1 = with flat-bed acoustic cladding

10 - Damper position

- NA = no spring return actuator (standard)
- NO = currentless OPEN - normally open
- NC = currentless CLOSED - normally closed

(only for drives with spring return)

With pneumatic drive correspondingly depressurised OPEN / depressurised CLOSED.

Volumetric flow controller VRAR

Specification texts

Volumetric flow controller in round design, for spiral duct connection, for use in supply and return air systems for constant or variable volumetric flow, room or duct pressure regulation. With positive control V_{\min} , V_{\max} or "CLOSED". Allowed pressure difference range: 50-1000 Pa, allowed ambient temperature 0 °C to +55 °C. Suitable for use with duct velocities of 1-12 m/s. It is possible to subsequently adjust the operating volumetric flows set ex works. Can be fitted position-independently. The output signal can be used for master/slave or parallel operation of several controllers or for actual value display 2-10 V DC (0-10 V DC), which corresponds to 0-100% of the set V_{\max} in DDC / ZLT systems (for more information, please refer to technical data sheet GUAC-SM3/SCH Universal **and 327VM-... Compact** from Gruner). Housing made of galvanised sheet steel with silicone-free damper blade seal made of PUR for airtight sealing. Measuring cross made of extruded aluminium profile, measuring cross support made of plastic (PA6), damper bearing made of brass. With electric controller, control voltage 24 V AC, 50 / 60 Hz, temperature compensation of 10-40 °C, wired and adjusted in factory. TÜV inspected according to **VDI 6022 Sheet 1 and 1946 Sheet 4**.

Product: SCHAKO type VRAR

- Housing leakage according to DIN EN 1751, class C, at a duct pressure of up to 1000 Pa.
- Leakage with closed damper blade according to DIN EN 1751 Class 4 (size NW100-125 class 3) at a duct pressure of up to 1000 Pa.
- Housing (at an extra charge) made of
 - galvanised sheet steel with DD coating (-DD)
 - Stainless steel 1.4301 (-V2)
 - Stainless steel 1.4571 (-V4)
- with spring return actuator (at an extra charge)
 - currentless "CLOSED" (-NC)
 - currentless "OPEN" (-NO)

With pneumatic drive correspondingly depressurised OPEN / depressurised CLOSED.

- With pneumatic controller, feed pressure 1.2 ± 0.1 bar, for use with duct velocities 3-12 m/s.
 - depressurised "CLOSED" or
 - Depressurised "OPEN"

Requirement: measuring air 0 °C to +50 °C, 5...95% relative humidity, non-condensing.

For controller selection (attachment assembly), see Controller selection on page 49.

Accessories (at an extra charge):

- Acoustic cladding (-DS2) made of 20 mm sound-absorbing material with sheet metal casing made of galvanised sheet steel, non-flammable according to DIN 4102-17.
- Flat-bed acoustic cladding (-FD1), made of 3 mm sound-absorbing material with sheet metal casing made of galvanised sheet steel
- Rubber lip seal (-GD1), on both sides, made of special rubber.
- Flat flange (pair), on both sides, acc. to DIN 24 154 / 5.
 - made of galvanised steel (-FF1)
 - made of stainless steel V2A / 1.4301 (-FF2)
- Metu flange (pair), on both sides.
 - made of galvanised steel (-MF1)
 - made of stainless steel V2A / 1.4301 (-MF2)
- Tension ring (pair), on both sides, to connect Metu flange to counter flange, loose.
 - made of galvanised steel (-SR1)
 - made of stainless steel V2A / 1.4301 (-SR2)
- Counter flange (pair), on both sides, to Metu flange, loose.
 - made of galvanised steel (-GF1)
 - made of stainless steel V2A / 1.4301 (-GF2)
- Duct silencer (-RS-N), rigid design, casing and perforated sheet made of galvanized sheet steel with mineral wool filling

Please note!

Tension rings, counter flanges and duct silencers must be ordered separately and are supplied loose!