



# Volumetric flow controller VRAQ



Leakage air flow with closed control damper according to DIN EN 1751, up to class 4

SCHAKO KG  
Steigstraße 25-27  
D-78600 Kolbingen  
Telephone +49 (0) 74 63 - 980 - 0  
[info@schako.de](mailto:info@schako.de)  
[schako.com](http://schako.com)

## Volumetric flow controller VRAQ

### Contents

<b>Description</b> .....	<b>3</b>
Installation .....	4
Construction .....	5
Model .....	5
Accessories .....	5
<b>Models and dimensions</b> .....	<b>6</b>
Blade profile .....	6
Dimensions .....	6
Standard controller selection .....	8
Minimum torque .....	9
Damper blade leakage .....	9
Accessories - dimensions .....	10
<b>Technical data</b> .....	<b>11</b>
Volumetric flow range H = 100-180 / W = 140-565 .....	11
Information for parameterisation .....	11
Volumetric flow range H = 201-1003 / W = 201-1003 .....	12
Acoustic data VRAQ H= 100-180 / W= 140-565 .....	13
Technical data of the control components .....	16
Circuit diagrams .....	17
Setting the operating potentiometers / calculation formulae .....	24
Room pressure control .....	26
Duct pressure control .....	26
Supply and return air volumetric flow control .....	27
Technical data of controllers and motors .....	28
Functional check .....	39
NMV-D3-MP and LMV-D3-MP: .....	39
Startup using PC-Tool .....	40
Startup using the setting and diagnostic device ZTH EU (Belimo) .....	41
Startup using the setting device GUIV-A .....	42
Controller selection .....	43
Maintenance and service .....	44
<b>Legend</b> .....	<b>44</b>
<b>Order code VRAQ</b> .....	<b>45</b>
<b>Order code ZSQ</b> .....	<b>46</b>
<b>Specification texts</b> .....	<b>47</b>

## Volumetric flow controller VRAQ

### Description

A volumetric flow controller is used for pressure-independent volumetric flow regulation in ventilation and air-conditioning systems. It is used to keep the volumetric flow constant (CAV) within specified limits or to control it variably (VAV) as a function of a command variable, for example a room temperature controller, DDC or bus system. For constant volumetric flows, the operating stages CLOSED /  $V_{\min}$  /  $V_{\text{mid}}$  /  $V_{\max}$  / OPEN are available in stage operation, controlled via relays or switches. The housing, measuring sensor, control flap, PI controller with pressure sensor and actuator form a closed control loop with feedback, allowing demand-dependent, energy-saving air-conditioning of the single rooms or areas of air-conditioning systems. When suitable electrical controller types are used, room or duct pressure regulation can be achieved.

The first adjustment of the  $V_{\min}$ ,  $V_{\max}$  and  $V_{\text{nenn}}$  operating volumetric flows is done prior to delivery ex works in accordance with specific customer requirements, although  $V_{\min}$  and  $V_{\max}$  can be easily changed at any time with the controller already mounted by means of the handheld control device or the PC-Tool software. When these values are set, the functions of all volumetric flow controllers are also checked. The operating point  $V_{\max}$  can be set in the range of 20 (30)...100% relative to the nominal volumetric flow of the box, while the operating point  $V_{\min}$  is set in the range of 0...100%, relative to  $V_{\max}$  or  $V_{\text{nenn}}$  (depending on the controller type). The maximum deviation of the volumetric flows is +/- 5%, relative to the nominal volumetric flow  $V_{\text{nenn}}$ , based on a calibration curve of 12 m/sec. At lower flow rates, the deviation in percent may increase.

For the calibration of the controllers, a curve with a flow rate of 12 m/sec. is available. For constant-volume volumetric flow controllers, the  $V_{\min}$  value will be set to the desired constant-volume value.

If the calibration curve must be changed on site, the controllers must either be recalibrated ex factory or the calibration curve must be changed on site by the customer service of Schako.

For the measurement of the differential pressure, SCHAKO is using its measuring principle by means of a double measuring cross made of extruded aluminium profile, to which 12 measuring points have been attached on the pressure and suction side, respectively, by the median line method, in order to determine average values. In comparison with measuring rods or measuring orifices having fewer measuring points, this gives a higher accuracy, allowing the inflow area required in front of the volumetric flow controller to be minimised (see page 4 - Installation Information).

When using the controllers in systems with heavy dust contamination, suitable filters must be used. For contaminated or aggressive air or air containing fluffy material, only those controller types must be used that incorporate a differential pressure sensor. Since the membrane zero point must not be changed in static sensors, the mounting instructions documented by the manufacturer must be adhered to. The volumetric flow controllers type VRAQ are not suitable for air containing sticky and greasy particles (e.g. kitchen exhaust air).

The external arrangement of the gears (only VRAQ equipped with several blades) has the advantage that, in comparison with internally arranged gears exposed to the air flow, they do not become soiled that quickly. A cover protects the gear wheels from outside dirt and reduces the personal risks of injury during assembly or maintenance.

Housing leakage according to DIN EN 1751, class C, at a duct pressure of up to 1000 Pa.

Leakage with closed damper blade according to DIN EN 1751, up to class 4, at a duct pressure of up to 1000 Pa.

The volumetric flow controller VRAQ has been tested successfully by TÜV SÜD in accordance with the following regulations:

- **VDI 6022, Sheet 1:**  
Hygienic requirements of ventilation and air-conditioning systems
- **DIN 1946, Sheet 4:**  
Air-conditioning technology - Health requirements

For maintenance, service, retrofitting, etc., inspection openings in sufficient number and size must be provided on site.

## Volumetric flow controller VRAQ

### Field of application

- for supply and return air systems
- for constant CAV or variable VAV installations.
- for positive control  $V_{min}$ ,  $V_{mid}$ ,  $V_{max}$ , "OPEN" or "CLOSED"
- For volumetric flow and linear pressure control
- in the differential pressure range 50 - 1,000 Pascal
- for ambient temperatures of 0 °C to +50 °C, requirement: measuring air 0 °C to +50°C, 5-95% relative humidity, non-condensing
- with command signal 0...10 V DC, 2...10 V DC, via MP bus (Belimo) or LON, Modbus, KNX, BACnet.
- with supply voltage 24 V AC (19.2..28.8 V) or 24 V DC (21.6..28.8 V)
- with DD varnish coating for aggressive media
- for regulating the air velocity in the duct in the range 1(2)...12 m/s (electric) and 3..12 m/s (pneumatic)
- can also be used with vertical axis

When using volumetric flow controllers in roof central units, in extreme cases, condensation can build up in the measuring pipes of the volumetric flow controller as a result of the large temperature differences between the air flowing through the volumetric flow controller and the surrounding air. This condensation can affect or damage the sensor. This is why for this field of application care must be taken to insulate the housings of the volumetric flow controllers and the measuring hoses (to prevent condensation) and to mount the controllers in such a way that any condensate formed on the outside of the measuring hoses can run downward and be drained (without entering the sensor).

Before connecting SCHAKO components to customer installations, any compatibility problems must be solved on-site and are not our area of responsibility.

### Attention:

We would like to point out that only suitable cleaning materials may be used for cleaning the stainless steel housings and stainless steel damper leaves!

### Installation

To avoid unnecessary controller errors, the min. distances according to the following table / drawings must be observed. For combinations of several connection pieces or pieces with fire dampers or silencers, the larger minimum distances must be observed.

All volumetric flow controllers can be assembled with horizontal or vertical damper axis.

Distance to:	VRAQ
Connection piece with bend	1 x diagonal
Other connection pieces: (e.g. T-junction, branching piece, reduction piece, etc.)	2 x diagonal
Fire damper:	2 x diagonal
Silencers:	2 x diagonal

### Installation information

#### Distance to a bent connection spigot

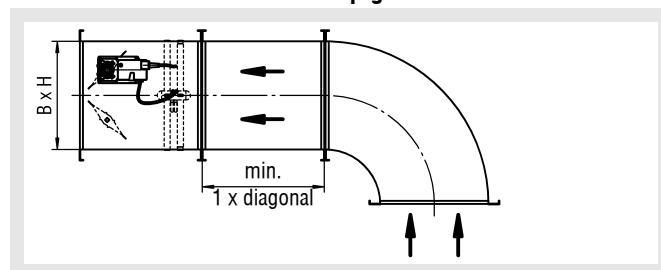

#### Distance to other connection pieces

(e.g. branching piece, reducing piece, T-junction, etc.)

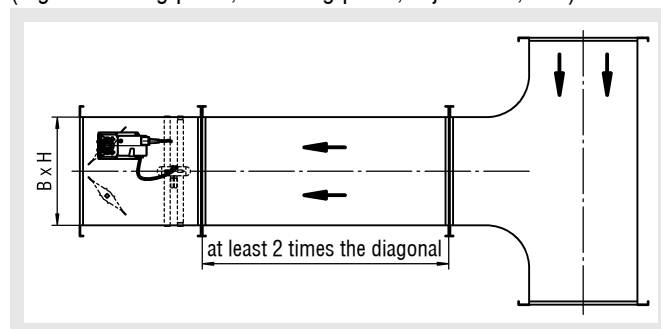

#### Distance to a fire damper

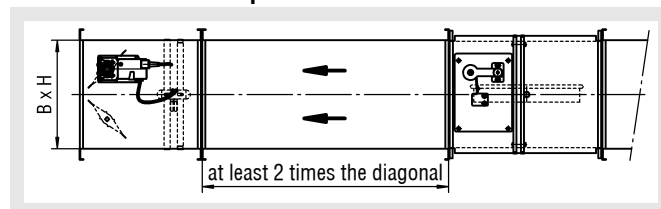

#### Distance to a silencer

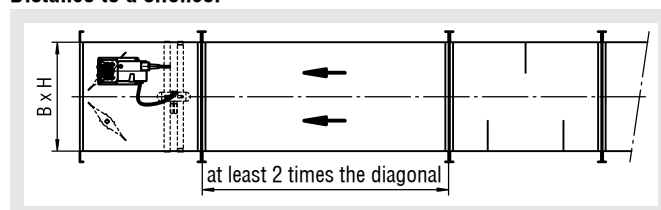

## Volumetric flow controller VRAQ

### Construction

#### Housing

- Galvanised sheet steel (-SV).
- Galvanised sheet steel with DD coating inside (-DD) (only available for VRAQ-HP and VRAQ-HU).

#### Damper leaf seal

- made of PUR, silicone-free.
- for airtight sealing design to DIN EN 1751.

#### Damper bearing

- Brass (VRAQ H=100).
- Plastic (VRAQ-HP and VRAQ-JP).
- Sintered (VRAQ-HU and VRAQ-JU).

#### Blades

- Opposed, made of galvanised steel sheet, not air-tight (VRAQ-HP and VRAQ-HU).
- opposed, made of extruded aluminium profiles, sealing air-tight to DIN EN 1751. (VRAQ-JP and VRAQ-JU).

#### Measuring cross

- Extruded aluminium profile.

#### Measuring cross support

- Plastic (PA6).

### Model

- VRAQ-... - Rectangular design, for duct connection to DIN EN 1505 / DIN 24190, only right-hand design available.
  - Housing leakage according to DIN EN 1751, class C, at a duct pressure of up to 1000 Pa.
- ...-HP - not sealing air-tight, with plastic bearing.
- ...-HU - not sealing airtight, with sintered bearing.
- ...-JP - sealing air-tight to DIN EN 1751, up to class 4, with plastic bearing.
- ...-JU - sealing air-tight to DIN EN 1751, up to class 4, with sintered bearing.
- ...-A... - with electric controller (height 100 - 1003 available)
  - Control voltage 24 V AC 50/60 Hz
  - alternatively with spring return actuator zero-current "CLOSED" or zero-current "OPEN" (at an extra charge).
  - alternatively with high-speed actuator running time 3-5 sec. for 90° angle of rotation (at an extra charge).
- with pneumatic controller (only height 201 to 1003 available)
  - by means of pneumatic controller in the design depressurised "CLOSED" (standard) or depressurised "OPEN".
  - Feed pressure 1.2 ± 0.1 bar

### Accessories

#### Acoustic cladding (-DS 4)

- made of sound-absorbing, insulating material 40 mm (pressed to 35 mm) with metal sheet casing made of galvanised sheet steel, non-flammable according to DIN 4102-17 (at an extra charge) Includes cage nuts (M8).

#### Mineral wool silencer (-ZSQ)

- Housing made of galvanised sheet steel
- Baffle frame made of galvanised sheet steel
- M3 metu profile on both sides.
- Mineral fibre boards according to DIN 4102 A2, with glass filament cover, biosoluble, wear-resistant

#### Please note!

**Mineral wool silencer ZSQ must be ordered separately!**

#### Note:

The plastic gear wheels consist of the plastic PA6. The plastic PA6 has the property of changing its dimensions as a function of the relative humidity. The gear wheels have been pre-conditioned for a standard climate of 23°C, 50% r.h..

If the gear wheels are exposed permanently or over a longer period to an r.h. of more than 60%, the damper may run sluggishly.

If the multi-leaf dampers are to be used in rooms in which the relative humidity is permanently >60%, we recommend using stainless steel gear wheels made of V2A (1.4301) instead of plastic gear wheels. Extra charge upon request.

## Volumetric flow controller VRAQ

### Models and dimensions

#### Blade profile

VRAQ-HP / VRAQ-HU

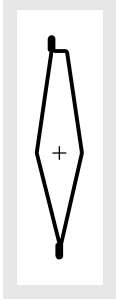

VRAQ-JP / VRAQ-JU

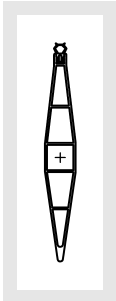

### Dimensions

H = 100-180 / W = 140-565  
with electric controller

VRAQ-...-DS0, without acoustic cladding

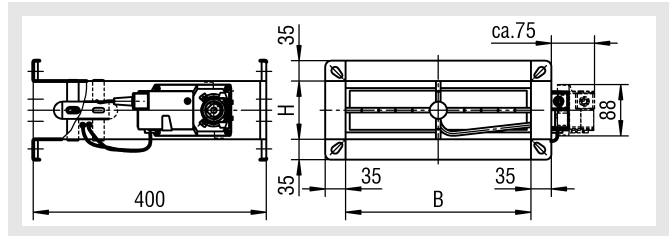

VRAQ-...-DS4, with acoustic cladding 40mm

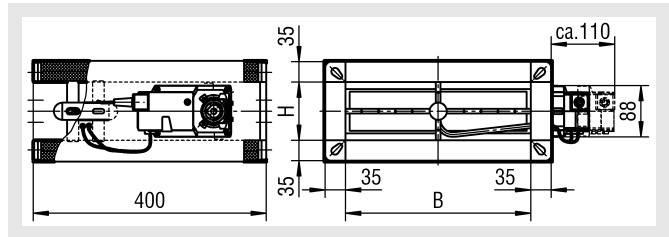

40 mm thick sound-absorbing material is pressed to 35 mm, with sheet metal casing

H = 100-180 / W = 140-565  
with pneumatic controller  
not available

### Available sizes

		B											
		140	160	180	201	225	252	318	357	400	449	503	565
H	100	X	X	X	X	X	X	X	--	--	--	--	--
	140	X	X	X	X	X	X	X	X	X	--	--	--
	160	X	X	X	X	X	X	X	X	X	X	--	--
	180	X	X	X	X	X	X	X	X	X	X	X	X

X = available

-- = not available

All combined lengths and heights available.

The VRAQ is only delivered in right-hand design. If the left-hand design, with the controller and motor on the left, is required, for mounting, the VRAQ must be turned by 180°.

## Volumetric flow controller VRAQ

H = 201-1003 / W = 201-1003  
with electric controller

VRAQ-...-DS0, without acoustic cladding

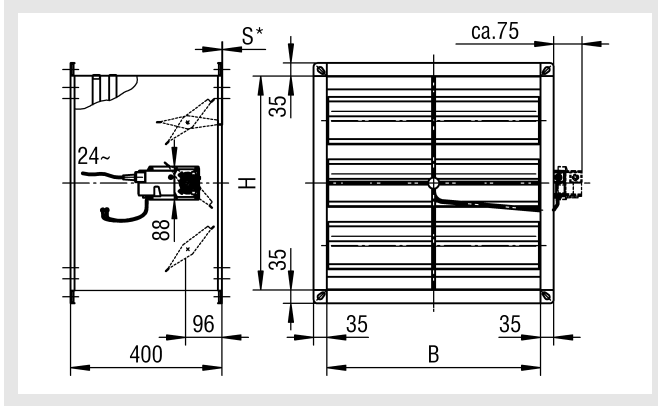

with pneumatic controller

VRAQ-...-DS0, without acoustic cladding

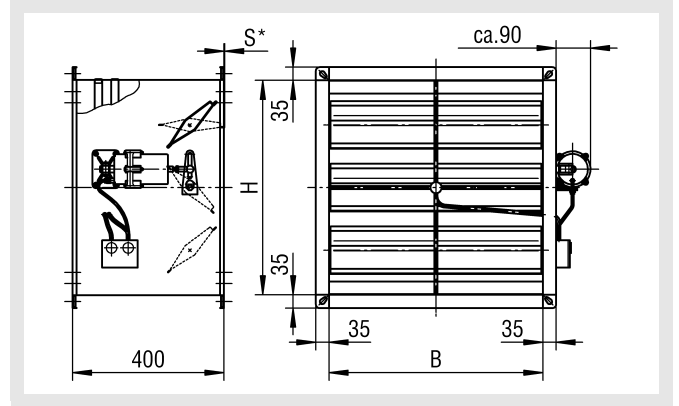

VRAQ-...-DS4, with acoustic cladding 40mm

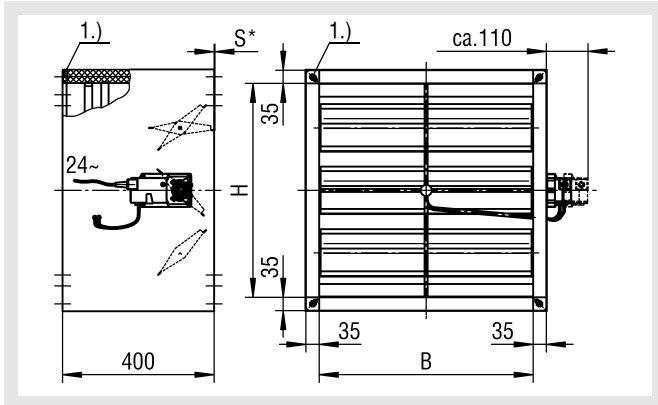

VRAQ-...-DS4, with acoustic cladding 40mm

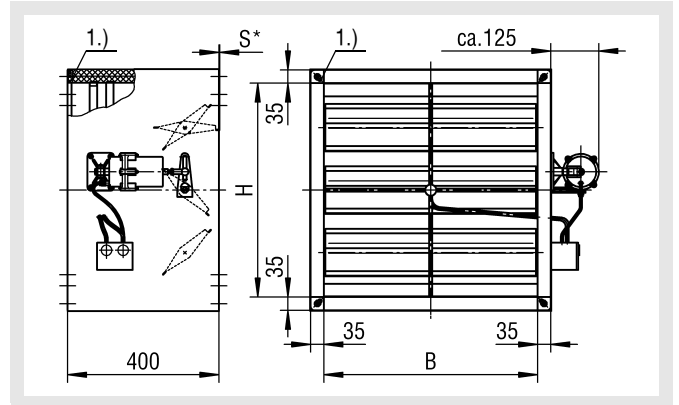

1.) Cage nut M8  
40 mm thick sound-absorbing material is pressed to 35 mm, with sheet metal casing

1.) Cage nut M8  
40 mm thick sound-absorbing material is pressed to 35 mm, with sheet metal casing

### Available sizes

VRAQ-HU-... / VRAQ-HP-...

H	B											S*					
	201	225	252	318	357	400	449	503	565	634	711		797	894	1003		
201	x	x	x	x	x	x	x	x	x	x	x	x	x	x	-	-	-
225	x	x	x	x	x	x	x	x	x	x	x	x	x	x	-	-	-
252	x	x	x	x	x	x	x	x	x	x	x	x	x	x	-	-	30
318	x	x	x	x	x	x	x	x	x	x	x	x	x	x	x	x	54
357	x	x	x	x	x	x	x	x	x	x	x	x	x	x	x	x	-
400	x	x	x	x	x	x	x	x	x	x	x	x	x	x	x	x	-
449	x	x	x	x	x	x	x	x	x	x	x	x	x	x	x	x	-
503	x	x	x	x	x	x	x	x	x	x	x	x	x	x	x	x	-
565	x	x	x	x	x	x	x	x	x	x	x	x	x	x	x	x	-
634	-	-	x	x	x	x	x	x	x	x	x	x	x	x	x	x	-
711	-	-	x	x	x	x	x	x	x	x	x	x	x	x	x	x	-
797	-	-	-	x	x	x	x	x	x	x	x	x	x	x	x	x	-
894	-	-	-	x	x	x	x	x	x	x	x	x	x	x	x	x	-
1003	-	-	-	x	x	x	x	x	x	x	x	x	x	x	x	x	-

### Available sizes

VRAQ-JU-... / VRAQ-JP-...

H	B											S*					
	201	225	252	318	357	400	449	503	565	634	711		797	894	1003		
201	x	x	x	x	x	x	x	x	x	x	x	x	x	x	-	-	-
225	x	x	x	x	x	x	x	x	x	x	x	x	x	x	-	-	-
252	x	x	x	x	x	x	x	x	x	x	x	x	x	x	-	-	-
318	-	-	-	-	-	-	-	-	-	-	-	-	-	-	-	-	-
357	x	x	x	x	x	x	x	x	x	x	x	x	x	x	x	x	-
400	x	x	x	x	x	x	x	x	x	x	x	x	x	x	x	x	-
449	x	x	x	x	x	x	x	x	x	x	x	x	x	x	x	x	-
503	x	x	x	x	x	x	x	x	x	x	x	x	x	x	x	x	-
565	x	x	x	x	x	x	x	x	x	x	x	x	x	x	x	x	-
634	-	-	x	x	x	x	x	x	x	x	x	x	x	x	x	x	-
711	-	-	x	x	x	x	x	x	x	x	x	x	x	x	x	x	-
797	-	-	-	x	x	x	x	x	x	x	x	x	x	x	x	x	-
894	-	-	-	x	x	x	x	x	x	x	x	x	x	x	x	x	-
1003	-	-	-	x	x	x	x	x	x	x	x	x	x	x	x	x	-

x = available  
-- = not available  
All combined lengths and heights available.  
S\* = projection length with a damper leaf position of 100% OPEN.

The VRAQ is only delivered in right-hand design.  
If the left-hand design, with the controller and motor on the left, is required, for mounting, the VRAQ must be turned by 180°.

# Volumetric flow controller VRAQ

## Standard controller selection

with electric controller (standard):

Attachment assembly	Controller / Drive	Actuator
-A003	LMV-D3-MP	Compact
-A004	NMV-D3-MP	Compact
-A005	SMV-D3-MP	Compact

with pneumatic controller (standard):

Attachment assembly	Controller / Drive	Actuator
-A106	RLP100 F003	AK31P1 F001
-A107	RLP100 F003	AK42P F003

### VRAQ-HP / VRAQ-HU / VRAQ-JP / VRAQ-JU

H = 100- 180 / W = 140-565

		B											
		140	160	180	201	225	252	318	357	400	449	503	565
H	100												
	140				A003								
	160												
	180												

### VRAQ-HP / VRAQ-HU

H = 201-1003 / W = 201-1003

		B													
		201	225	252	318	357	400	449	503	565	634	711	797	894	1003
H	201														
	225														
	252														
	318														
	357														
	400														
	449														
	503														
	565														
	634														
	711														
797															
894															
1003															

### VRAQ-HP / VRAQ-HU

H = 201-1003 / W = 201-1003

		B													
		201	225	252	318	357	400	449	503	565	634	711	797	894	1003
H	201														
	225														
	252														
	318														
	357														
	400														
	449														
	503														
	565														
	634														
	711														
797															
894															
1003															

### VRAQ-JP / VRAQ-JU

H = 201-1003 / W = 201-1003

		B													
		201	225	252	318	357	400	449	503	565	634	711	797	894	1003
H	201														
	225														
	252														
	318														
	357														
	400														
	449														
	503														
	565														
	634														
	711														
797															
894															
1003															

### VRAQ-JP / VRAQ-JU

H = 201-1003 / W = 201-1003

		B													
		201	225	252	318	357	400	449	503	565	634	711	797	894	1003
H	201														
	225														
	252														
	318														
	357														
	400														
	449														
	503														
	565														
	634														
	711														
797															
894															
1003															

-- = not available

## Volumetric flow controller VRAQ

### Minimum torque

#### VRAQ-HP / VRAQ-HU

H	B																
	140	160	180	201	225	252	318	357	400	449	503	565	634	711	797	894	1003
100																	
140																	
160																	
180																	
201	--	--	--														
225	--	--	--														
252	--	--	--														
318	--	--	--														
357	--	--	--														
400	--	--	--														
449	--	--	--														
503	--	--	--														
565	--	--	--														
634	--	--	--														
711	--	--	--														
797	--	--	--														
894	--	--	--														
1003	--	--	--														

4 Nm

5 Nm

10 Nm

### Damper blade leakage

#### VRAQ, classification according to DIN EN 1751

H dimension in mm	Test pressure in				
	100	250	500	750	1000
200 - 599	Class 3	Class 3	Class 3	Class 3	Class 3
600 - 1003	Class 4	Class 4	Class 4	Class 4	Class 3

H 600 - 1003, class 4 at 1000 Pa available at an extra charge

#### VRAQ-JP / VRAQ-JU

H	B																
	140	160	180	201	225	252	318	357	400	449	503	565	634	711	797	894	1003
100																	
140																	
160																	
180																	
201																	
225																	
252																	
318	--	--	--	--	--	--	--	--	--	--	--	--	--	--	--	--	--
357																	
400																	
449																	
503																	
565																	
634	--	--	--	--	--	--	--	--	--	--	--	--	--	--	--	--	--
711	--	--	--	--	--	--	--	--	--	--	--	--	--	--	--	--	--
797	--	--	--	--	--	--	--	--	--	--	--	--	--	--	--	--	--
894	--	--	--	--	--	--	--	--	--	--	--	--	--	--	--	--	--
1003	--	--	--	--	--	--	--	--	--	--	--	--	--	--	--	--	--

4 Nm

5 Nm

10 Nm

15 Nm

-- = not available

## Volumetric flow controller VRAQ

### Accessories - dimensions

#### Mineral wool silencer (-ZSQ) with baffles MWK-OB

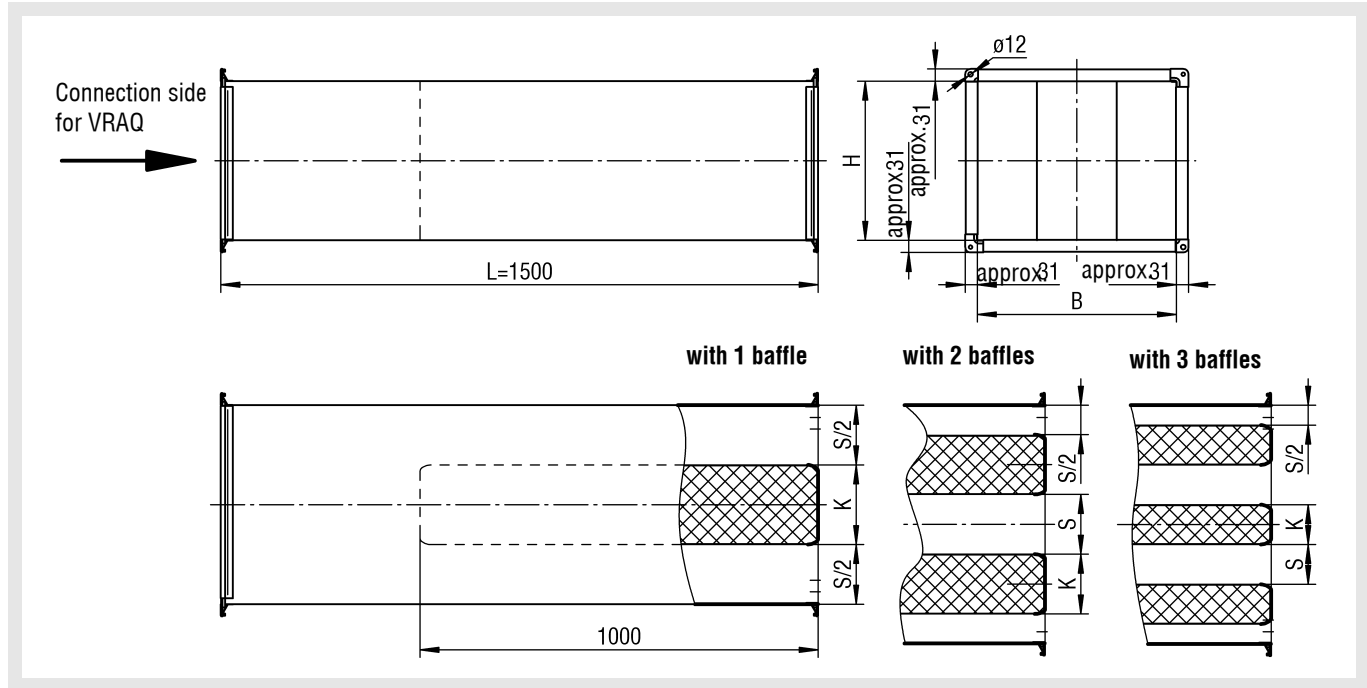

#### Available sizes and insertion loss for mineral wool silencer (-ZSQ)

H (mm)	B (mm)	KA (-)	K (mm)	S (mm)	D <sub>e</sub> [dB/Okt]							
					f <sub>m</sub> (Hz)							
					63	125	250	500	1000	2000	4000	8000
100	140	1	100	40	2	6	16	26	48	48	33	26
140	160	1	100	60	2	5	15	24	45	45	30	24
160	180	1	100	80	1	4	12	20	40	41	26	18
180	201	1	100	101	1	3	9	18	36	37	22	13
201	225	1	100	125	1	2	8	19	32	26	16	11
225	252	1	100	152	1	2	7	16	26	24	14	8
252	318	1	100	218	0	1	3	6	13	13	8	5
318	357	1	200	157	2	5	13	23	30	28	15	9
357	400	1	200	200	1	4	11	19	25	20	11	7
400	449	1	200	249	1	4	8	10	17	17	9	6
449	503	1	200	303	1	4	7	8	15	15	8	5
503	565	1	200	365	1	3	6	6	13	13	6	5
565	634	3	100	111	1	2	9	22	36	30	17	12
634	711	3	100	137	1	2	8	18	28	24	14	10
711	797	2	200	199	1	4	11	19	25	20	11	7
797	894	2	200	247	1	4	8	10	17	17	9	6
894	1003	2	200	302	1	4	7	8	15	15	8	5
1003												

The possible width and height combinations are listed on page 7.

The parameters KA (number of baffles), K (baffle strength) and S (gap width) depend on the width B.

**Please note!**  
Mineral wool silencer ZSQ must be ordered separately!

## Volumetric flow controller VRAQ

### Technical data

Volumetric flow range H =100-180 / W = 140-565

with electric controller (standard)

H (mm)	V		B (mm)											
			140	160	180	201	225	252	318	357	400	449	503	565
100	min.	(m <sup>3</sup> /h)	51	58	65	73	81	90	115	--	--	--	--	--
		[l/s]	14	16	18	20	23	25	32	--	--	--	--	--
	max.	(m <sup>3</sup> /h)	605	691	778	870	972	1080	1374	--	--	--	--	--
		[l/s]	168	192	216	242	270	300	382	--	--	--	--	--
140	min.	(m <sup>3</sup> /h)	71	81	91	102	114	127	161	180	202	--	--	--
		[l/s]	20	23	25	28	32	36	45	50	56	--	--	--
	max.	(m <sup>3</sup> /h)	847	968	1089	1216	1361	1524	1923	2159	2419	--	--	--
		[l/s]	235	269	302	338	378	423	534	600	672	--	--	--
160	min.	(m <sup>3</sup> /h)	81	92	104	116	130	145	183	206	231	259	--	--
		[l/s]	23	26	29	32	36	41	51	57	64	72	--	--
	max.	(m <sup>3</sup> /h)	968	1106	1244	1389	1555	1742	2198	2468	2765	3103	--	--
		[l/s]	269	307	346	386	432	484	611	685	768	862	--	--
180	min.	(m <sup>3</sup> /h)	91	104	117	130	146	164	206	232	259	291	326	366
		[l/s]	25	29	33	36	41	46	57	65	72	81	91	102
	max.	(m <sup>3</sup> /h)	1089	1244	1400	1563	1750	1960	2473	2776	3110	3491	3911	4393
		[l/s]	302	346	389	434	486	544	687	771	864	970	1086	1220

-- = not available

- MIN values refer to air velocity of 1 m/s
- MAX values refer to air velocity of 12 m/s

**When the air volume drops below the  $V_{\min}$  shown in the chart, the correct functioning of the volumetric flow controller is no longer guaranteed!**

### Information for parameterisation

**Attention, the following specifications are important for the programming of the volumetric flow controllers:**

- this table specifies the complete measuring range of the standard controller (volumetric flow range).
- If the customer absolutely wants a calibration curve different from 12 m/s, it must be specified!
- When the air volume drops below the  $V_{\min}$  shown in the chart, the correct functioning of the volumetric flow controller is no longer guaranteed!
- If only one air volume is specified in the order (as  $V_{\max}$  value), the volumetric flow controller will be delivered as variable volumetric flow controller. The  $V_{\min}$  value will be set to the value specified in the catalogue.
- If only one air volume is specified in the order (as  $V_{\min}$  or  $V_{\text{konstant}}$  value or without value specification), then the volumetric flow controller will be delivered as a constant volumetric flow controller. The volume specified in the order is set to the  $V_{\min}$  value, and the  $V_{\max}$  value is set to 100%.
- The air volumes can be changed using setting devices specific for the controller make, depending on the calibration curve set ex works.
- The Gruner controller, type **327VM-...** Compact, can be used with a sensor linearised to an air velocity of 1 m/s!
- For the parameter setting of the control components (all controllers), an air density of 1.2 kg/m<sup>3</sup> has been taken into account.
- Belimo compact controllers are height-compensated. They are calibrated ex works to the system height in question of the specified installation site.
- If no system height is given in the order, the controllers will be set to the elevation of the delivery address.
- If the customer does not specify whether the "Parallel" or "Master/Slave" operating mode is desired, the controller is set for the parallel operation (Master/Slave mode only upon customer request).
- for alternative controller types, a V-min of 2 m/s or more can be set (pneumatic controller: 3 m/s or more)

## Volumetric flow controller VRAQ

Volumetric flow range H = 201-1003 / W = 201-1003

with electric controller (standard)

H (mm)	V	B (mm)														
		201	225	252	318	357	400	449	503	565	634	711	797	894	1003	
201	m³/h	min.	146	163	183	230	259	290	325	364	409	459	515	577	--	--
		max.	1745	1954	2188	2761	3100	3473	3899	4368	4906	5505	6174	6921	--	--
	l/s	min.	41	46	51	64	72	81	91	101	114	128	143	160	--	--
		max.	485	543	608	767	861	965	1083	1213	1363	1529	1715	1923	--	--
225	m³/h	min.	163	183	204	258	289	324	364	408	458	514	576	646	--	--
		max.	1954	2187	2449	3091	3470	3888	4364	4889	5492	6162	6911	7747	--	--
	l/s	min.	46	51	57	72	81	90	101	113	127	143	160	180	--	--
		max.	543	608	680	859	964	1080	1212	1358	1526	1712	1920	2152	--	--
252	m³/h	min.	183	204	229	289	324	363	408	457	513	575	645	723	811	--
		max.	2188	2449	2743	3462	3886	4355	4888	5476	6151	6902	7740	8676	9732	--
	l/s	min.	51	57	64	80	90	101	113	127	143	160	179	201	226	--
		max.	608	680	762	962	1079	1210	1358	1521	1709	1917	2150	2410	2703	--
318	m³/h	min.	230	258	289	364	409	458	514	576	647	726	814	913	1024	--
		max.	2761	3091	3462	4369	4904	5495	6168	6910	7762	8710	9767	10949	12281	--
	l/s	min.	64	72	80	101	114	127	143	160	180	202	226	254	285	--
		max.	767	859	962	1214	1362	1526	1713	1919	2156	2419	2713	3041	3411	--
357	m³/h	min.	259	289	324	409	459	514	577	647	726	815	914	1025	1149	1289
		max.	3100	3470	3886	4904	5506	6169	6925	7757	8714	9778	10965	12292	13788	15469
	l/s	min.	72	81	90	114	128	143	161	180	202	227	254	285	319	358
		max.	861	964	1079	1362	1529	1714	1924	2155	2421	2716	3046	3414	3830	4297
400	m³/h	min.	290	324	363	458	514	576	647	725	814	913	1024	1148	1288	1445
		max.	3473	3888	4355	5495	6169	6912	7759	8692	9763	10956	12286	13772	15448	17332
	l/s	min.	81	90	101	127	143	160	180	202	226	254	285	319	358	402
		max.	965	1080	1210	1526	1714	1920	2155	2414	2712	3043	3413	3826	4291	4814
449	m³/h	min.	325	364	408	514	577	647	726	813	914	1025	1150	1289	1445	1621
		max.	3899	4364	4888	6168	6925	7759	8709	9757	10959	12298	13791	15459	17341	19455
	l/s	min.	91	101	113	143	161	180	202	226	254	285	320	358	402	451
		max.	1083	1212	1358	1713	1924	2155	2419	2710	3044	3416	3831	4294	4817	5404
503	m³/h	min.	364	408	457	576	647	725	813	911	1023	1148	1288	1443	1619	1816
		max.	4368	4889	5476	6910	7757	8692	9757	10930	12277	13777	15450	17318	19426	21795
	l/s	min.	101	113	127	160	180	202	226	253	284	319	358	401	450	505
		max.	1213	1358	1521	2669	2155	2414	2710	3036	3410	3827	4292	4811	5396	6054
565	m³/h	min.	409	458	513	647	726	814	914	1023	1149	1290	1446	1621	1819	2040
		max.	4906	5492	6151	7762	8714	9763	10959	12277	13791	15475	17354	19453	21821	24481
	l/s	min.	114	127	143	180	202	226	254	284	319	358	402	451	505	567
		max.	1363	1526	1709	2156	2421	2712	3044	3410	3831	4299	4821	5404	6061	6800
634	m³/h	min.	--	--	575	726	815	913	1025	1148	1290	1447	1623	1819	2041	2289
		max.	--	--	6902	8710	9778	10956	12298	13777	15475	17364	19473	21829	24486	27471
	l/s	min.	--	--	160	202	227	254	285	319	358	402	451	506	567	636
		max.	--	--	1917	2419	2716	3043	3416	3827	4299	4823	5409	6064	6802	7631
711	m³/h	min.	--	--	645	814	914	1024	1150	1288	1446	1623	1820	2040	2289	2568
		max.	--	--	7740	9767	10965	12286	13791	15450	17354	19473	21839	24480	27459	30807
	l/s	min.	--	--	179	226	254	285	320	358	402	451	506	567	636	713
		max.	--	--	2150	2713	3046	3413	3831	4292	4821	5409	6066	6800	7628	8558
797	m³/h	min.	--	--	--	912	1025	1148	1289	1443	1621	1819	2040	2287	2565	2878
		max.	--	--	--	10949	12292	13772	15459	17318	19453	21829	24480	27441	30781	34534
	l/s	min.	--	--	--	253	285	319	358	401	451	506	567	636	713	800
		max.	--	--	--	3041	3414	3826	4294	4811	5404	6064	6800	7623	8550	9593
894	m³/h	min.	--	--	--	1023	1149	1288	1445	1619	1819	2041	2289	2565	2877	3228
		max.	--	--	--	12281	13788	15448	17341	19426	21821	24486	27459	30781	34527	38737
	l/s	min.	--	--	--	284	319	358	402	450	505	567	636	713	799	897
		max.	--	--	--	3411	3830	4291	4817	5396	6061	6802	7628	8550	9591	10760
1003	m³/h	min.	--	--	--	1148	1289	1445	1621	1816	2040	2289	2568	2878	3228	3622
		max.	--	--	--	13779	15469	17332	19455	21795	24481	27471	30807	34534	38737	43460
	l/s	min.	--	--	--	319	358	402	451	505	567	636	713	800	897	1006
		max.	--	--	--	3828	4297	4814	5404	6054	6800	7631	8558	9593	10760	12072

- MIN values refer to air velocity of 1 m/s  
 - MAX values refer to air velocity of 12 m/s

H=318 for VRAQ-JP / VRAQ-JU not available.  
 -- = not available

## Volumetric flow controller VRAQ

Acoustic data VRAQ H= 100-180 / W= 140-565

A-weighted sound power level  $L_{WA}$  [dB(A)]

### Flow generated noise

H (mm)	$v_k$ (m/s)	$\Delta p_f = 200 \text{ Pa}$											$\Delta p_f = 400 \text{ Pa}$											
		B (mm)											B (mm)											
		140	160	180	201	225	252	318	357	400	449	503	565	140	160	180	201	225	252	318	357	400	449	503
100	3	49	50	52	54	54	55	56	--	--	--	--	55	56	57	60	61	62	--	--	--	--	--	
	6	51	52	53	56	56	57	58	--	--	--	--	57	58	59	62	62	63	64	--	--	--	--	--
	9	54	55	56	57	57	58	59	--	--	--	--	60	61	62	63	63	64	65	--	--	--	--	--
	12	55	56	57	58	58	59	60	--	--	--	--	61	62	63	64	64	65	66	--	--	--	--	--
140	3	50	50	52	55	55	56	57	57	58	--	--	56	56	58	60	60	61	62	62	63	--	--	--
	6	52	53	54	57	57	58	59	60	61	--	--	58	59	60	63	63	64	65	66	67	--	--	--
	9	55	56	58	60	60	61	62	63	64	--	--	61	62	64	66	66	67	68	69	70	--	--	--
	12	57	58	60	64	64	65	66	67	68	--	--	63	64	66	70	70	71	72	73	74	--	--	--
160	3	50	51	53	55	55	56	57	57	58	58	--	56	57	58	60	60	61	62	62	63	64	--	--
	6	52	54	55	58	58	59	60	61	62	63	--	58	60	61	64	64	65	66	67	68	69	--	--
	9	57	58	60	64	64	65	66	67	68	69	--	63	64	66	66	68	68	69	70	71	72	--	--
	12	58	60	62	66	66	67	68	69	70	71	--	64	66	68	72	72	73	74	74	75	75	--	--
180	3	51	52	53	55	55	56	57	57	58	58	59	57	58	59	61	61	62	63	63	64	64	65	65
	6	53	54	57	59	59	60	61	62	63	64	64	59	60	63	65	65	66	66	67	68	69	69	70
	9	58	60	62	65	65	66	67	68	69	70	70	64	66	68	70	70	71	71	72	73	73	74	74
	12	60	62	64	67	67	68	69	70	71	72	72	66	68	70	73	73	74	74	75	75	76	76	77
201	3	51	52	54	55	55	56	57	57	58	58	59	57	58	60	62	62	63	64	64	65	65	66	66
	6	54	55	57	60	60	61	62	62	63	63	64	60	61	63	66	66	67	68	68	69	69	70	70
	9	60	62	64	66	66	67	68	68	69	69	70	66	68	70	70	70	71	72	72	73	73	74	74
	12	62	64	66	68	68	69	70	70	71	71	72	68	70	72	73	73	74	75	75	76	76	77	77

$L_{WA}$  [dB(A)]

### Radiated noise VRAQ-...-DSO (without acoustic cladding)

H (mm)	$v_k$ (m/s)	$\Delta p_f = 200 \text{ Pa}$											$\Delta p_f = 400 \text{ Pa}$										
		B (mm)											B (mm)										
		140	160	180	201	225	252	318	357	400	449	503	565	140	160	180	201	225	252	318	357	400	449
100	3	42	43	44	45	45	46	47	--	--	--	--	48	49	50	51	51	52	53	--	--	--	--
	6	44	46	47	49	49	50	51	--	--	--	--	50	52	53	55	55	56	57	--	--	--	--
	9	47	49	51	53	53	54	55	--	--	--	--	53	55	57	59	59	60	61	--	--	--	--
	12	51	53	54	56	56	57	58	--	--	--	--	57	59	60	62	62	63	64	--	--	--	--
140	3	43	44	45	46	46	47	48	49	50	--	--	49	50	51	52	52	53	54	55	56	--	--
	6	45	47	48	50	50	51	52	53	54	--	--	51	53	54	56	56	57	58	59	60	--	--
	9	48	50	52	54	54	55	56	57	58	--	--	54	56	58	60	60	61	62	63	64	--	--
	12	52	54	55	57	57	58	59	60	61	--	--	58	60	61	63	63	64	64	64	65	--	--
160	3	44	45	46	47	47	48	49	50	51	52	--	50	51	52	53	53	54	55	56	57	58	--
	6	46	48	49	51	51	52	53	54	55	56	--	52	54	55	57	57	58	59	60	61	62	--
	9	49	51	53	55	55	56	57	58	59	60	--	55	57	59	61	61	62	63	64	64	65	--
	12	53	55	56	58	58	59	60	61	62	63	--	59	61	62	62	63	63	64	64	65	66	--
180	3	45	46	47	48	48	49	50	51	52	52	53	51	52	53	54	54	55	55	56	56	57	58
	6	47	49	50	52	52	53	54	55	56	57	57	53	55	56	58	58	59	60	61	61	62	63
	9	50	52	54	56	56	57	58	59	60	61	61	56	58	59	61	62	63	63	64	64	65	65
	12	54	56	57	59	59	60	61	62	63	64	64	60	62	63	63	64	64	65	65	66	66	67
201	3	46	47	48	49	49	50	51	51	52	52	53	52	53	54	54	54	55	56	56	57	57	58
	6	48	50	51	53	53	54	55	55	56	56	57	54	56	57	59	59	60	61	61	62	62	63
	9	51	53	55	57	57	58	59	59	60	60	61	57	59	61	62	62	63	64	64	65	65	66
	12	55	57	58	60	60	61	62	62	63	63	63	61	63	64	64	64	65	66	66	67	67	68

$L_{WA}$  [dB(A)]

-- = not available

## Volumetric flow controller VRAQ

Radiated noise VRAQ-...-DS4 (with acoustic cladding)

H (mm)	v <sub>k</sub> (m/s)	Δp <sub>t</sub> = 200 Pa											Δp <sub>t</sub> = 400 Pa																								
		B (mm)											B (mm)																								
		140	160	180	201	225	252	318	357	400	449	503	565	140	160	180	201	225	252	318	357	400	449	503	565												
100	3	36	37	38	39	39	40	41	--	--	--	--	42	43	44	45	45	46	47	--	--	--	--	42	43	44	45	45	46	47	--	--	--	--	--		
	6	38	40	41	43	43	44	45	--	--	--	--	44	46	47	49	49	50	51	--	--	--	--	44	46	47	49	49	50	51	--	--	--	--	--		
	9	41	43	45	47	47	48	49	--	--	--	--	47	49	51	53	53	54	55	--	--	--	--	47	49	51	53	53	54	55	--	--	--	--	--		
	12	45	47	48	50	50	51	52	--	--	--	--	51	53	54	56	56	57	58	--	--	--	--	51	53	54	56	56	57	58	--	--	--	--	--		
140	3	37	38	39	40	40	41	42	43	44	--	--	43	44	45	46	46	47	48	49	50	--	--	43	44	45	46	46	47	48	49	50	--	--	--		
	6	39	41	42	44	44	45	46	47	48	--	--	45	47	48	50	50	51	52	53	54	--	--	45	47	48	50	50	51	52	53	54	--	--	--		
	9	42	44	46	48	48	49	50	51	52	--	--	48	50	52	54	54	55	56	57	58	--	--	48	50	52	54	54	55	56	57	58	--	--	--		
	12	46	48	49	51	51	52	53	54	55	--	--	52	54	55	57	57	58	58	58	59	--	--	52	54	55	57	57	58	58	58	59	--	--	--		
160	3	38	39	40	41	41	42	43	44	45	46	--	--	44	45	46	47	47	48	49	50	51	52	--	--	44	45	46	47	47	48	49	50	51	52	--	--
	6	40	42	43	45	45	46	47	48	49	50	--	--	46	48	49	51	51	52	53	54	55	56	--	--	46	48	49	51	51	52	53	54	55	56	--	--
	9	43	45	47	49	49	50	51	52	53	54	--	--	49	51	53	55	55	56	57	58	58	59	--	--	49	51	53	55	55	56	57	58	58	59	--	--
	12	47	49	50	52	52	53	54	55	56	57	--	--	53	55	56	56	57	57	58	58	59	60	--	--	53	55	56	56	57	57	58	58	59	60	--	--
180	3	39	40	41	42	42	43	44	45	46	46	47	47	45	46	47	48	48	49	49	50	50	51	51	52	45	46	47	48	48	49	49	50	50	51	51	52
	6	41	43	44	46	46	47	48	49	50	51	51	51	47	49	50	52	52	53	54	55	55	56	56	57	47	49	50	52	52	53	54	55	55	56	56	57
	9	44	46	48	50	50	51	52	53	54	55	55	55	50	52	53	55	56	57	57	58	58	59	59	60	50	52	53	55	56	57	57	58	58	59	59	60
	12	48	50	51	53	53	54	55	56	57	58	58	58	54	56	57	57	58	58	59	59	60	60	61	61	54	56	57	57	58	58	59	59	60	60	61	61
201	3	40	41	42	43	43	44	45	45	46	46	47	47	46	47	48	48	48	49	50	50	51	51	52	52	46	47	48	48	48	49	50	50	51	51	52	52
	6	42	44	45	47	47	48	49	49	50	50	51	51	48	50	51	53	53	54	55	55	56	56	57	57	48	50	51	53	53	54	55	55	56	56	57	57
	9	45	47	49	51	51	52	53	53	54	54	55	55	51	53	55	56	56	57	58	58	59	59	60	60	51	53	55	56	56	57	58	58	59	59	60	60
	12	49	51	52	54	54	55	56	56	57	57	58	58	55	57	58	58	58	59	60	60	61	61	62	62	55	57	58	58	58	59	60	60	61	61	62	62

L<sub>WA</sub> [dB(A)]

-- = not available

## Volumetric flow controller VRAQ

Acoustic data VRAQ H= 201-1003 / W= 201-1003

Inflow area A (m<sup>2</sup>)

H (mm)	B (mm)													
	201	225	252	318	357	400	449	503	565	634	711	797	894	1003
201	0,04	0,05	0,05	0,06	0,07	0,08	0,09	0,10	0,11	0,13	0,14	0,16	-	-
225	0,05	0,05	0,06	0,07	0,08	0,09	0,10	0,11	0,13	0,14	0,16	0,18	-	-
252	0,05	0,06	0,06	0,08	0,09	0,10	0,11	0,13	0,14	0,16	0,18	0,20	0,23	-
318	0,06	0,07	0,08	0,10	0,11	0,13	0,14	0,16	0,18	0,20	0,23	0,25	0,28	-
357	0,07	0,08	0,09	0,11	0,13	0,14	0,16	0,18	0,20	0,23	0,25	0,28	0,32	0,36
400	0,08	0,09	0,10	0,13	0,14	0,16	0,18	0,20	0,23	0,25	0,28	0,32	0,36	0,40
449	0,09	0,10	0,11	0,14	0,16	0,18	0,20	0,23	0,25	0,29	0,32	0,36	0,40	0,45
503	0,10	0,11	0,13	0,16	0,18	0,20	0,23	0,25	0,28	0,32	0,36	0,40	0,45	0,51
565	0,11	0,13	0,14	0,18	0,20	0,23	0,25	0,28	0,32	0,36	0,40	0,45	0,51	0,57
634	--	--	0,16	0,20	0,23	0,25	0,29	0,32	0,36	0,40	0,54	0,51	0,57	0,64
711	--	--	0,18	0,23	0,26	0,28	0,32	0,36	0,40	0,45	0,51	0,57	0,64	0,71
797	--	--	--	0,25	0,29	0,32	0,36	0,40	0,45	0,51	0,57	0,64	0,71	0,80
894	--	--	--	0,28	0,32	0,36	0,40	0,45	0,51	0,57	0,64	0,71	0,80	0,90
1003	--	--	--	0,32	0,36	0,40	0,45	0,51	0,57	0,64	0,71	0,80	0,90	1,01

Flow generated noise (A = 1 m<sup>2</sup>)

v <sub>K</sub> (m/s)	Δp <sub>t</sub> = 100 Pa							Δp <sub>t</sub> = 250 Pa							Δp <sub>t</sub> = 500 Pa							Δp <sub>t</sub> = 1000 Pa							
	L <sub>W1</sub> [dB/oct]						L <sub>WA1</sub> [dB(A)]	L <sub>W1</sub> [dB/oct]						L <sub>WA1</sub> [dB(A)]	L <sub>W1</sub> [dB/oct]						L <sub>WA1</sub> [dB(A)]	L <sub>W1</sub> [dB/oct]						L <sub>WA1</sub> [dB(A)]	
	f <sub>m</sub> (Hz)							f <sub>m</sub> (Hz)							f <sub>m</sub> (Hz)							f <sub>m</sub> (Hz)							
	125	250	500	1000	2000	4000	125	250	500	1000	2000	4000	125	250	500	1000	2000	4000	125	250	500	1000	2000	4000	125	250	500	1000	2000
3	62	61	60	59	56	52	63	68	68	67	67	65	63	72	74	74	73	73	71	69	78	81	81	81	81	80	77	86	
6	68	67	66	65	63	58	70	73	73	72	71	69	67	76	78	79	78	77	76	74	82	84	85	84	84	84	82	90	
9	73	73	73	71	69	65	76	79	78	78	76	75	73	82	79	80	81	80	80	78	86	86	88	87	87	86	85	92	
12	75	74	74	72	70	67	77	82	81	81	79	78	76	85	85	85	84	84	83	81	89	88	90	89	90	89	88	95	

Radiated noise (A = 1 m<sup>2</sup>)

v <sub>K</sub> (m/s)	Δp <sub>t</sub> = 100 Pa							Δp <sub>t</sub> = 250 Pa							Δp <sub>t</sub> = 500 Pa							Δp <sub>t</sub> = 1000 Pa							
	L <sub>W1</sub> [dB/oct]						L <sub>WA1</sub> [dB(A)]	L <sub>W1</sub> [dB/oct]						L <sub>WA1</sub> [dB(A)]	L <sub>W1</sub> [dB/oct]						L <sub>WA1</sub> [dB(A)]	L <sub>W1</sub> [dB/oct]						L <sub>WA1</sub> [dB(A)]	
	f <sub>m</sub> (Hz)							f <sub>m</sub> (Hz)							f <sub>m</sub> (Hz)							f <sub>m</sub> (Hz)							
	125	250	500	1000	2000	4000	125	250	500	1000	2000	4000	125	250	500	1000	2000	4000	125	250	500	1000	2000	4000	125	250	500	1000	2000
3	69	61	55	48	44	41	58	75	68	62	56	51	50	65	82	75	68	53	58	53	72	90	82	77	72	67	60	80	
6	75	67	61	52	48	44	64	80	72	66	59	54	51	69	85	80	73	66	62	57	76	95	85	79	75	70	66	83	
9	80	73	67	57	53	49	69	85	75	70	61	58	54	73	86	81	75	67	65	61	77	96	87	82	76	71	69	85	
12	82	76	69	61	56	52	72	87	77	72	63	60	58	75	90	83	78	70	66	64	80	97	88	84	76	73	71	86	

### Correction factor

(for flow generated and radiated noise)

A (m <sup>2</sup> )	0,04	0,06	0,08	0,10	0,12	0,16	0,20	0,25	0,36	0,40	0,50	0,60	0,80	1,00
KF (-)	-14	-12	-11	-10	-9	-8	-7	-6	-5	-4	-3	-2	-1	0

-- = not available

## Volumetric flow controller VRAQ

### Technical data of the control components

#### Measured value collection and control function

The measured value collection is carried out via a flow-favouring double measuring cross. The measuring openings are distributed over the measuring cross according to the median line method. The pressure differential formed on the measuring cross is determined by means of a dynamic or static measuring sensor. The measured values are averaged to give an average value which represents a measuring quantity for the volumetric flow. The controller compares the actual value signal with the setpoint value and sends an output signal to the electric actuator which adjusts the controller deviation independent of pressure changes in the duct network.

The volumetric flow controllers of the Belimo make (Compact, Universal) and the Gruner make are delivered by SCHAKO as standard with the operating mode (Y signal,  $U_5$  signal) 2-10 V DC. When activated by 2 V DC, the  $V_{min}$  volume is controlled, the smallest possible  $V_{min}$  volume that can be controlled can be seen from the "Volumetric Flow Range" tables. **When the air volume drops below the  $V_{min}$  shown in the chart, the correct functioning of the volumetric flow controller is no longer guaranteed!**

#### Positive control damper "CLOSED"

Airtight sealing to DIN EN 1751 is achieved on site either via a positive control "CLOSED" by means of a switch or a relay, or via an actuator signal of 0 V DC applied to the input Y (all Compact controllers equipped with the operating mode 2-10V DC). Accordingly, the drive will likewise close the flap in operating range 2 - 10 V DC (however, this does not apply to the operating range 0-10 V DC), and the VAV control will be inactive. To do so, it must be ensured that the actuator signal is  $< 0.1$  V DC. This is why in rooms where defined pressures are active (e.g. laboratories), the flap should be closed via a digital on-site switching contact.

The volumetric flow controllers of the Siemens make can be delivered with the operating mode 0-10 V DC or 2-10 V DC.

If the Compact controllers of the Belimo make must be delivered with the operating mode 0-10V DC on customer request, please note that a positive control "CLOSED" can only be effected via a switching contact with diode.

#### Positive control damper "OPEN"

Supports smoke extraction or is used as a safety position. The volumetric flow controller is in this case inactive, and the damper is driven to the mechanical open position. In this case, it is recommended using an actuator with spring return function (e.g. Belimo make, actuator type VRU-... with NF24A-VST). This ensures that the actuator flap will be driven into the defined "OPEN" end position also via an digital contact or in case of power failure.

#### $V_{min}$ control to a minimum volumetric flow

Depending on requirement or by not assigning them, individual areas can be set to stand-by operation. In this way, minimum room flushing with greatly reduced energy expenditure is achieved.

#### $V_{max}$ control to a maximum volumetric flow

Individual or several rooms are supplied for a short period with a maximum volumetric flow. This allows, for example, a room through-ventilation or efficient heating to be effected.

#### Continuous operation

As a function of the continuous driving signal and the programmed operating range (0-10 V DC or 2-10 V DC), the volumetric flow controller will regulate the volumetric flow linearly between the setpoint values of  $V_{min}$  and  $V_{max}$ .

#### Constant operation

If terminal 3 (Y command signal) has not been assigned, the  $V_{min}$  value is controlled as a constant volumetric flow (Belimo make: L-/NMV-D3-MP / Gruner make: 327VM-... , GUAC-SM3...).

#### Two-stage volumetric flow rate control

- |          |   |
|----------|---|
| Stage 1: | If terminal 3 (Y command signal) has not been assigned, the set $V_{min}$ value is controlled as a constant volumetric flow.  |
| Stage 2: | If AC 24 V is applied to terminal 3, the volumetric flow controller keeps the value set as $V_{max}$ constant. With a switch or a contact in a connection line a "secondary volume flow control" is possible. |

## Volumetric flow controller VRAQ

### Circuit diagrams

Circuit diagram electric controller (standard)

Compact controller Belimo make: LMV-D3-MP / NMV-D3-MP / SMV-D3-MP

VAV with analogue command signal

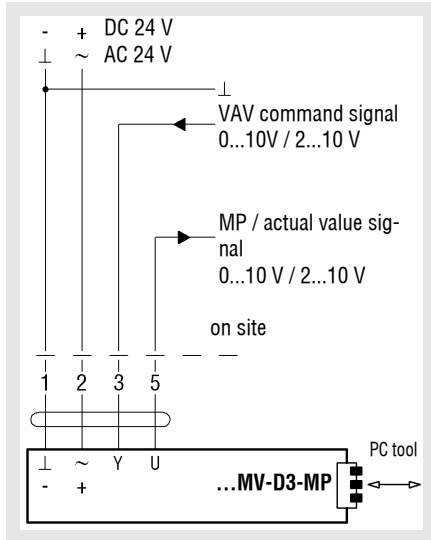

VAV with lock (CLOSED)  
Mode 2-10 V DC

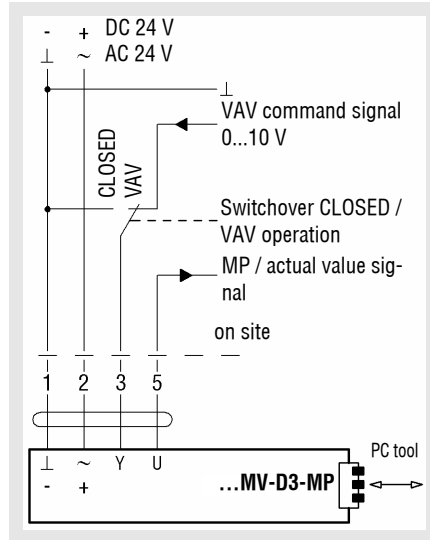

MP bus activation with integrated switch

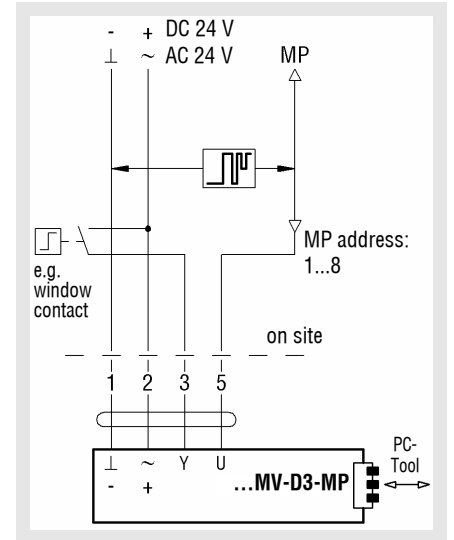

Lock mode (CLOSED)

In the 2...10 V mode, the following function can be carried out with a 0...10 V signal:

### Cable designations

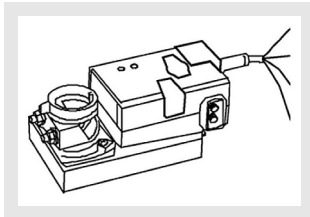

No.	Designation	Wire colour	Function
1	- ⊥	black	Feed AC/DC 24 V
2	+ ~	red	
3	← Y	white	VAV / CAV command signal
5	→ U	orange	- Actual value signal - MP bus connection

Command signal Y	Volumetric flow	Function
< 0,1 V **	0	Damper CLOSED, VAV control inactive
0,2...2 V	$V_{min}$	$V_{min}$ operating stage active
2...10 V	$V_{min} \dots V_{max}$	Continuous operation $V_{min} \dots V_{max}$

\*\* Attention: Controller/DDC must be able to pull the command signal to 0 V.

### CAV operation / positive contacts

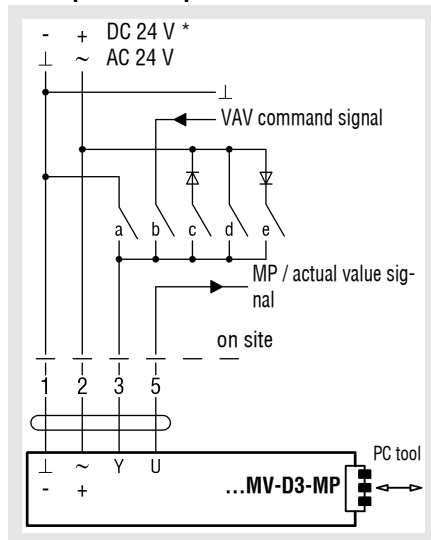

**Note:** Please ensure mutual locking of the contacts!

### CAV function for MV-D3-MP























Mode setting	0...10 V	0...10 V	0...10 V	0...10 V	0...10 V	Mode setting
Signal	⊥	0...10 V	~	~	~	Signal
Function	-	2...10 V	⊥	+	⊥	Function
a) CLOSED			c) CLOSED*			Damper CLOSED
		b) VAV				$V_{min} \dots V_{max}$
everything open - $V_{min}$ active						CAV - $V_{min}$
				e) OPEN*		Damper OPEN
			d) $V_{max}$			CAV - $V_{max}$



- Contact closed, function active
- Contact closed, function active, in mode 2 ...10 V only
- Contact open

\* not available for DC 24 V supply

## Volumetric flow controller VRAQ

Table of LED functions for LMV-D3-MP / NMV-D3-MP / SMV-D3-MP

Application	Function	Description / action	LED pattern	Adaption Address	LED 1 power LED 2 status
N1 operation	Status display	- 24 V power supply o.k. - - VAV-Compact ready for operation	LED 1 LED 2	 	
S1 service function	Synchronisation	Synchronisation started by: a) Operating / service unit b) Manual trigger device at the VAV-Compact c) Power ON behaviour	LED 1 LED 2	 	
S2 service function	Adaption	Adaptation started by: a) Operating / service unit b) Key on the VAV-Compact	LED 1 LED 2	 	
V1 VAV service	VAV service active	a) Simultaneously press both keys «Adaptation» & «Address» b) VAV service will be activated: - until 24 V supply is switched off - until both keys are pressed again - after 2 hours have passed	LED 1 LED 2	  	
	Lack of air	Damper opens as actual volume is too low	LED 1 LED 2	 	
	Target volume reached	Control circuit balanced	LED 1 LED 2	 	
	Air excess	Damper closes as actual volume is too high	LED 1 LED 2	 	
B1 bus operation	Addressing via MP master (Acknowledgement at the VAV-Compact)	a) Addressing has been triggered at the MP master	LED 1 LED 2	 	
		b) Press addressing key LED will switch to the communication display as soon as the addressing process is complete.	LED 1 LED 2	 	
B2 bus operation	Addressing via MP master (with serial number)	Addressing at the MP master was triggered, LED will switch to the communication display as soon as the addressing process is complete.	LED 1 LED 2	 	
B3 bus operation communication	MP-PP display Communication	Communication display via MP master or operating / service unit	LED 1 LED 2	 	

-  green LED (power) is lit
-  yellow LED (status) is lit
-  yellow LED (status) is flashing

- 1.) Synch time
- 2.) Adaptation time
- 3.) MP communication

## Volumetric flow controller VRAQ

### Circuit diagram of electric controller (alternative)

#### Universal controller Belimo make VRU-D3/M1-BAC VAV with analogue command signal

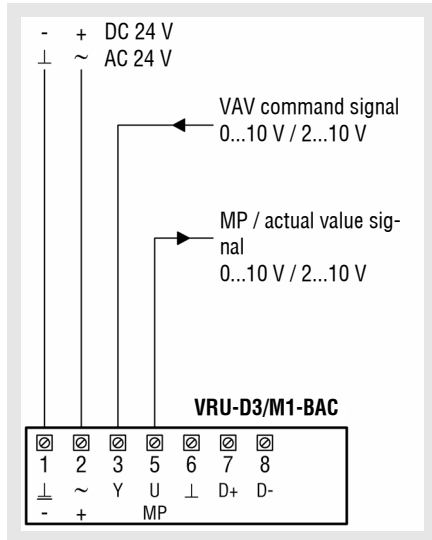

#### CAV operation

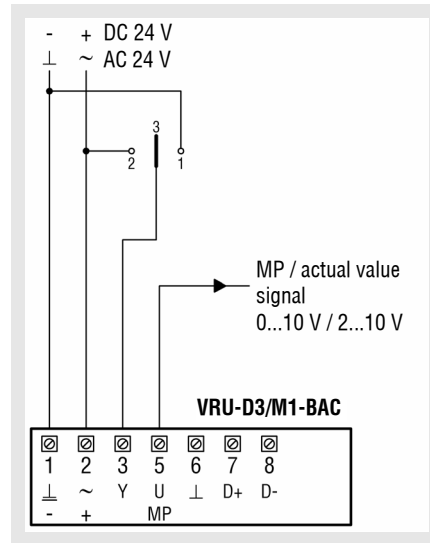

Command signal Y	Volumetric flow	Function
< 0,1 V **	0	Damper CLOSED, VAV control inactive
0,2...2 V	$V_{min}$	$V_{min}$ operating stage active
2...10 V	$V_{min} \dots V_{max}$	Continuous operation $V_{min} \dots V_{max}$

\*\*Attention: Controller/DDC must be able to pull the command signal to 0 V.

#### Function - Analogue CAV step control

1. Damper CLOSED
2.  $V_{max}$
3.  $V_{min}$

#### BACnet MS/TP / Modbus RTU operation

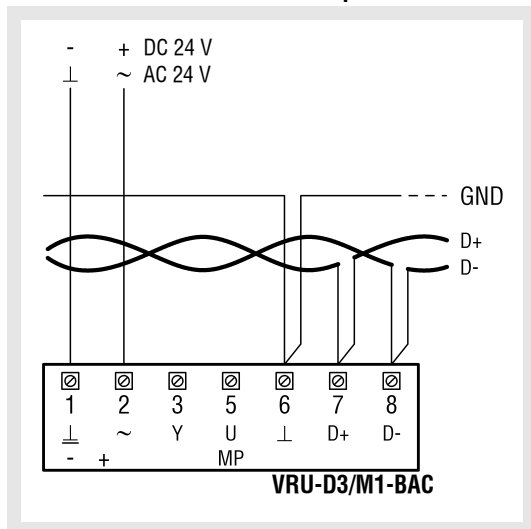

#### Priority rule - BACnet/Modbus control

1. z1
2. z2
3. Bus watchdog
4. a) Adaption  
b) Synchronisation
5. Bus positive control
6. Bus setpoint value: Min...Max

#### BACnet MS/TP / Modbus RTU hybrid operation

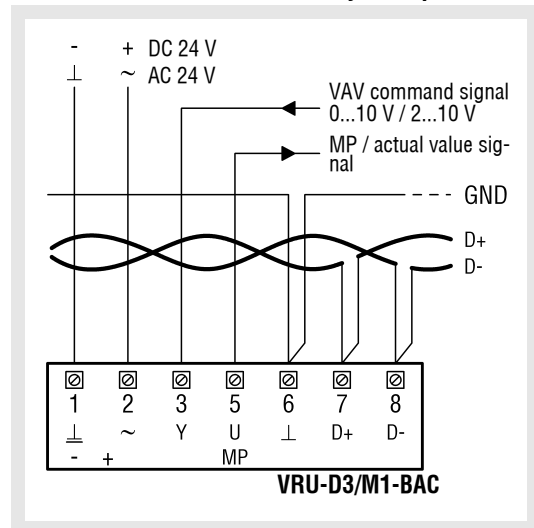

#### Priority rule - BACnet/Modbus hybrid operation

1. z1
2. z2
3. Bus watchdog
4. a) Adaption  
b) Synchronisation
5. Bus positive control
6. Y stage: actuator CLOSED / MIN / MAX
7. Bus setpoint value: Min...Max

## Volumetric flow controller VRAQ

### Circuit diagram of electric controller (alternative)

Controller Gruner make:  
**GUAC-SM3/SCH Universal**  
 Connection diagram

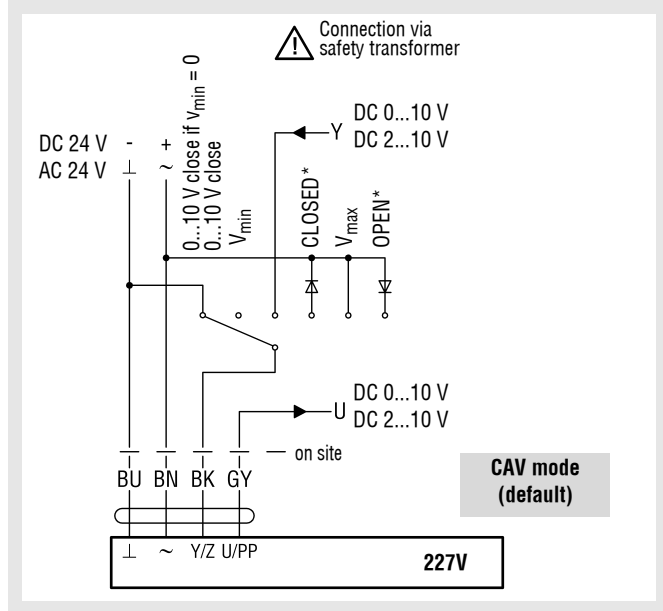

Edit:	The selector value allows values to be changed. The position of the arrow shows the set value. The changes are displayed as soon as the selector is moved $\pm 10^\circ$ out of its position.
Flow / Unit:	To set the desired current volumetric flow unit in $\text{m}^3/\text{h}$ and $\text{l/s}$ .
$V_{\min}$ :	To set the required min. volumetric flow (setpoint value $Y = 0 \text{ V} / 2 \text{ V}$ )
$V_{\max}$ :	To set the required max. volumetric flow (setpoint value $Y = 10 \text{ V}$ )
Mode:	(To set the direction of rotation) 0-n...0-10 V normal (clockwise) 2-n...2-10 V normal (clockwise) 0-i ...0-10 V inverse (counterclockwise) 2-i ...2-10 V inverse (counterclockwise)
Diag:	Diagnostics menu: oP = opens the damper leaf cL = closes the damper leaf Hi = activates $V_{\max}$ Lo = activates $V_{\min}$ on = Diagnostic mode is on, motor is off off = Diagnostic mode is off, display Y setpoint
$V_{\text{nom}}$ :	To display and set the nominal volumetric flow (by the box manufacturer only).
(for more information, please refer to the technical data sheet GUAC-SM3/SCH Universal <b>327VM-024-05-MB</b> from Gruner)	

### Setting

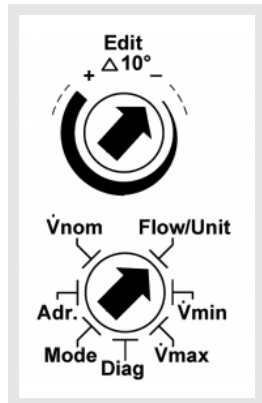

## Volumetric flow controller VRAQ

### Circuit diagram of electric controller (alternative)

#### Controller Gruner make 327V? Compact Connection diagram

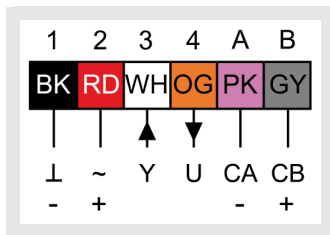
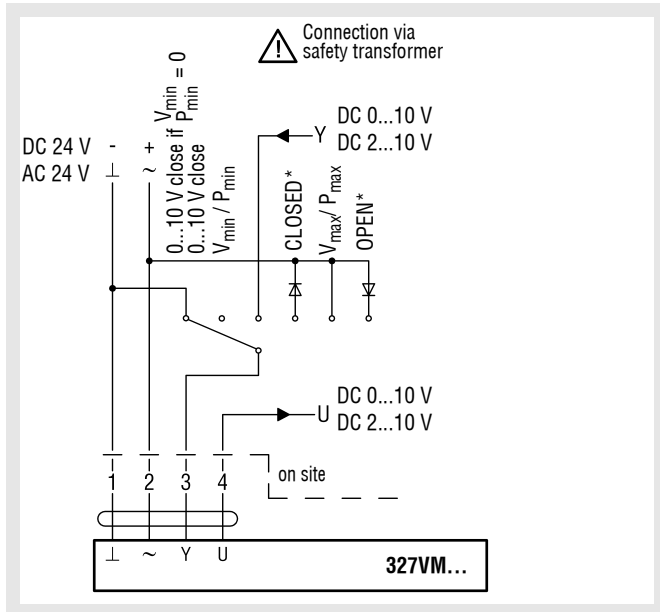

No.	Designation	Wire colour	Function
1	—	- black	Power supply 24 V AC/DC
2	—	+ red	
3	←	Y white	Input signal 0-10 V DC
4	→	U orange	Feedback signal 0-10 V DC
A	CA -	pink	Modbus RTU connection (RS485)
B	CB +	grey	

Act / Set:	Display of current value / setpoint value or positive control.
Min:	To set the required min. value (setpoint value Y = 0 / 2 VDC).
Max:	To set the required max. value (setpoint value Y = 10 VDC).
Diag:	Diagnostics menu: y/u - Display of setpoint value / feedback signal oP - opens the damper leaf cL - closes the damper leaf Hi - activates max. value Lo - activates min. value bE - activates intermediate value St - diagnostic mode is on, motor is off Adp - adaptation travel (only 15 Nm or Modbus version) 123 - software version
Mode:	0An (0-10 V DC   standard direction of rotation) 2An (2-10 V DC   standard direction of rotation)
Addr.	Setting the Modbus address (1...247) and Modbus parameters (if the actuator is Modbus-capable).
Nom:	Display & setting of the nominal value, depending on the VAV box (setting is only possible with volumetric flow rate control).
Settings:	327 VAV controllers can be set directly on the display. All 327 VAV controllers can communicate with the setting device GUIV3-M or with the setting software Win-VAV2 via the service connection. When using the setting software WIN-VAV2, the GUIV3-S serves as an interface converter.
Accessories:	GUIV3-M – service plug + setting device GUIV3-M WIN-VAV2 bundle – service plug + interface converter GUIV3-S + setting software WIN-VAV2

## Volumetric flow controller VRAQ

### Circuit diagram of electric controller (alternative)

Controller make Siemens: GLB181.1 E/3  
Connection diagram

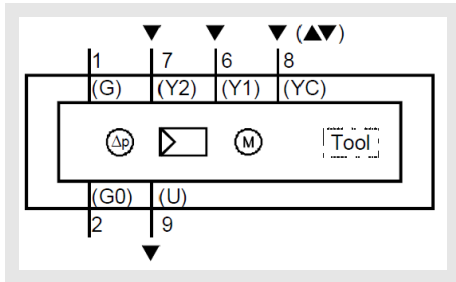

Controller make Siemens: GDB181.1 E/KN / GLB181.1 E/KN  
Connection diagram for KNX

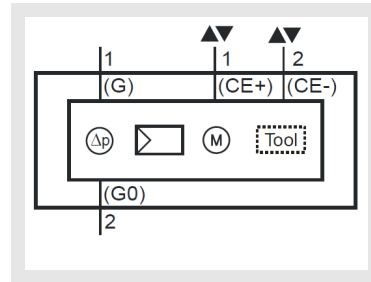

Constant control between  $V_{max}$  and  $V_{min}$  and complete lock

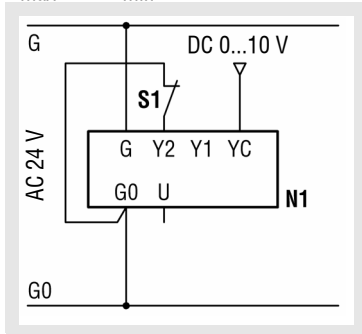

The wires of the connecting cable are colour-coded and labelled:

AB	AF	CO	Meaning
Cable 1: supply / black sheath			
1	red	G	Voltage phase AC 24 V
2	black	G0	Voltage neutral conductor AC 24 V
Cable 2: bus connection / green sheath			
1	red	CE+	Bus connection (KNX / PL-Kink)
2	black	CE-	Bus connection (KNX / PL-Kink)

AB = Wire labelling

AF = Wire colour

CO = Terminal code (Landis & Staefa)

The wires of the connecting cable are colour-coded and labelled:

AB	AF	CO	Meaning
1	red	G	Phase AC 24 V
2	black	G0	System zero AC 24 V
6	violet	Y1	"Actuator direction of rotation" actuator signal (G0 switched), depends on the setting of AST10 or ACS931 (factory setting=clockwise rotation)
7	orange	Y2	"Actuator direction of rotation" actuator signal (G0 switched), depends on the setting of AST10 or ACS931 (factory setting=counter-clockwise rotation)
8	grey	YC	Volumetric flow command signal DC 0...10 V (setpoint) or communication signal, with connected setting device AST10 or interface converter AST11
9	pink	U	Volumetric flow measuring signal DC 0...10 V (actual value)

AB = Wire labelling

AF = Wire colour

CO = Terminal code (Landis & Staefa)

## Volumetric flow controller VRAQ

### Circuit diagram of electric controller (alternative)

Controller make Delta Controls DVC-V322A / DVC-V322AF

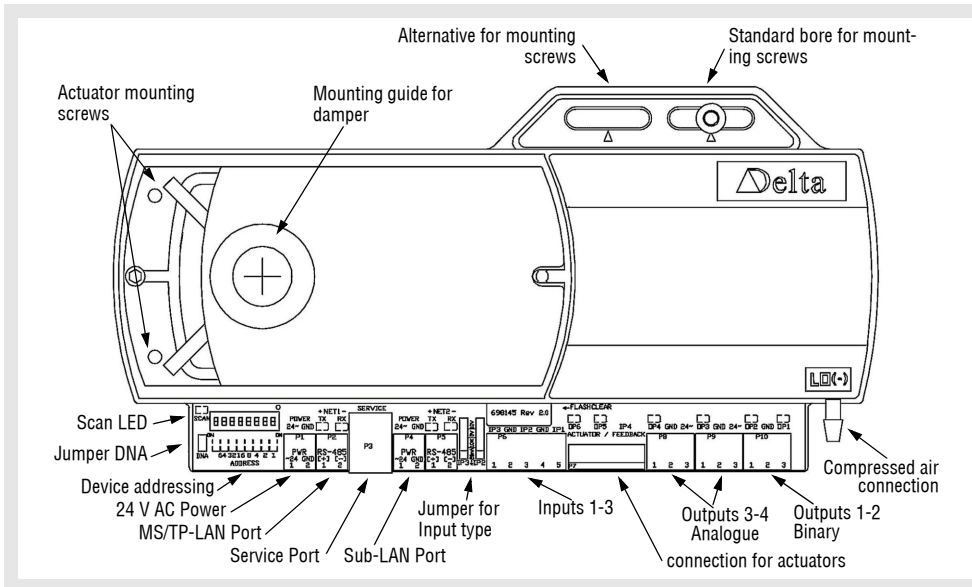

Accessories:

- RPT-768 - Delta network repeater for BACnet MS/TP
- TRM-768 - Delta network terminator for BACnet MS/TP
- CON-768 - Delta network converter

### Circuit diagram of pneumatic controller (standard) Compact controller Sauter make RLP100 F003

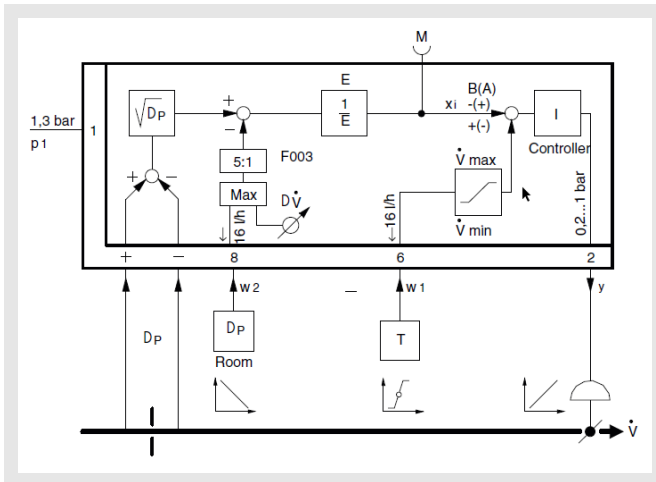

### Circuit diagram of pneumatic controller (alternative) Compact controller Sauter make RLP100 F914

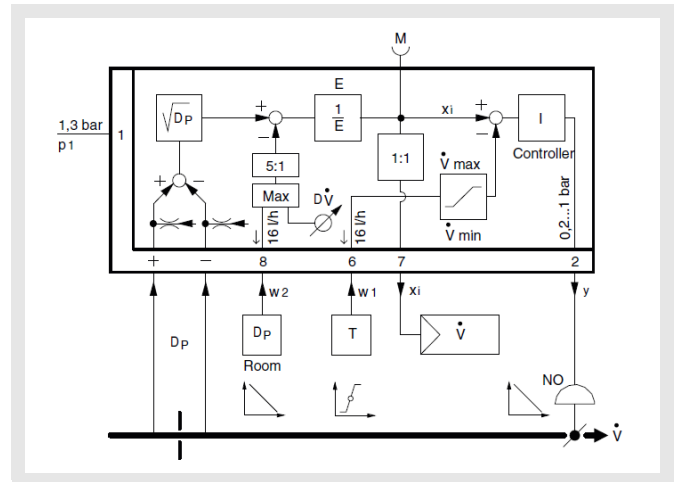

- w = Command variable
- $\Delta p$  = Pressure difference
- v = Output pressure
- y (2) = Output to the actuator

## Volumetric flow controller VRAQ

### Setting the operating potentiometers / calculation formulae

#### Set value for $V_{\max}$

$$EW_{V_{\max}} = \frac{V_{\max}}{V_{\text{nenn}}} \times 100\%$$

The required volumetric flow that is to flow at the 10 V DC command signal at terminal 3 (w/Y) or with positive control  $V_{\max}$  is set in % at the  $V_{\max}$  potentiometer of the controller, the ZTH EU device or PC-Tool. This value refers to the set  $V_{\text{nenn}}$  nominal volumetric flow.

#### Set value for $V_{\min}$

$$EW_{V_{\min}} = \frac{V_{\min}}{V_{\text{nenn}} \text{ oder } V_{\max}} \times 100\%$$

The required volumetric flow that is to flow with the 0 V DC command signal (operating mode 0-10 V DC) or with the 2 V DC driving signal (operating mode 2 - 10 V DC) at terminal 3 (w/Y) or with positive control  $V_{\min}$  is set in % on the  $V_{\min}$  potentiometer of the controller, the ZTH EU device or PC-Tool. This value refers to the set  $V_{\text{nenn}}$  nominal volumetric flow.

#### Calculation of the $U_5$ voltage value

##### Operating mode: 2 - 10 V DC:

$$U_5 = \frac{V_{\max}}{V_{\text{nenn}}} \times 8V + 2V \quad V_{\max} \text{ values}$$

$$U_5 = \frac{V_{\min}}{V_{\text{nenn}}} \times 8V + 2V \quad V_{\min} \text{ values}$$

##### Operating mode: 0 - 10 V DC:

$$U_5 = \frac{V_{\max}}{V_{\text{nenn}}} \times 10V \quad V_{\max} \text{ values}$$

$$U_5 = \frac{V_{\min}}{V_{\text{nenn}}} \times 10V \quad V_{\min} \text{ values}$$

#### Calculation of the $V_{\text{nenn}}$ volumetric flow

$$V_{\text{nenn}} = EK \times F \times 3600$$

#### Attention:

The  $V_{\text{nenn}}$  value changes as a function of the set calibration curve. The standard calibration curve is 12 m/s.

EW (%)	=	Set value
EK (m/s)	=	Calibration curve
$U_5$ (V DC)	=	$U_5$ signal
F (m <sup>2</sup> )	=	Surface

## Volumetric flow controller VRAQ

Actual value measurement via feedback signal  $U_5$  using a voltmeter or PC tool

### Terminal assignment

LMV-D3-MP / NMV-D3-MP / SMV-D3-MP

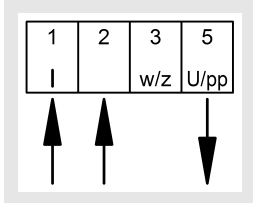

Supply voltage: 24 V AC/DC (terminals 1+2)  
 Measurement output 2 - 10 V DC (terminals 1+5)  
 Measurement output 0 - 10 V DC (terminals 1+5)

The actual value signal  $U_5$  is a real feedback of the volumetric flow actual value for monitoring and controlling the air through-put volume.

### 327VM/GUAC

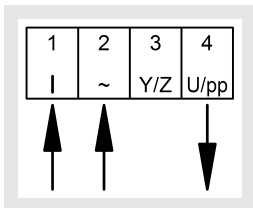

Supply voltage: 24 V AC/DC (terminals 1+2)  
 Measurement output 2 - 10 V DC (terminals 1+4)  
 Measurement output 0 - 10 V DC (terminals 1+4)

### $U_5$ signal 0-10 V DC

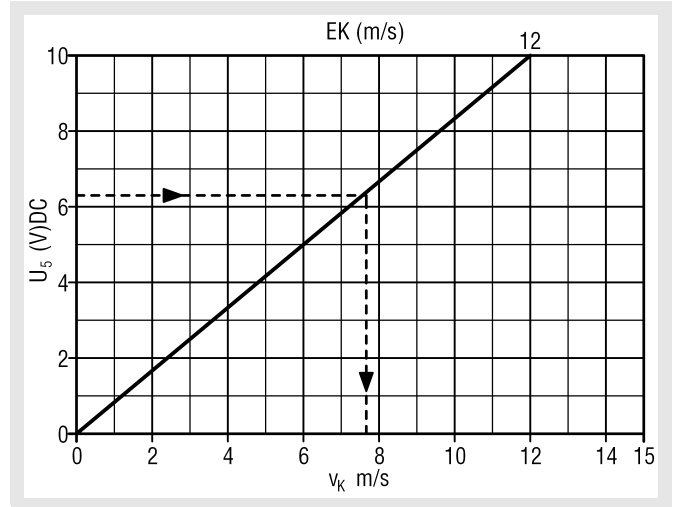

### Example

Assume: Measurement output signal  $U_5 = 6.3$  V DC  
 Calibration value VRAQ = 12 m/sec

Measured value: Duct velocity = 7.6 m/s

Air volume: Duct velocity x area  $m^2$  x 3600 =  $m^3/h$

### $U_5$ signal 2-10 V DC

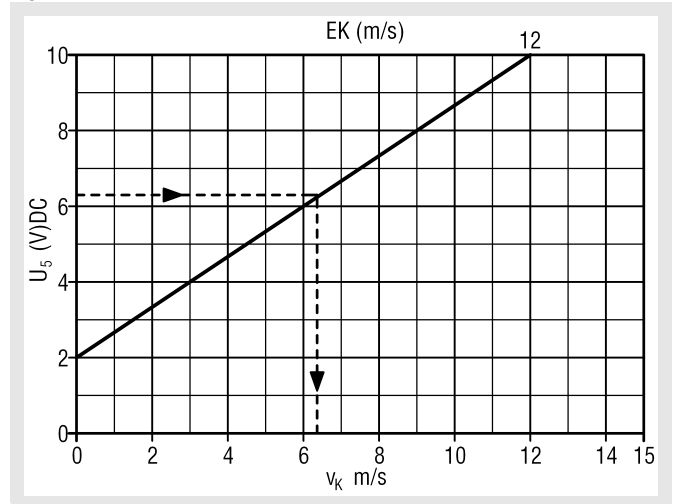

### Example

Assume: Measurement output signal  $U_5 = 6.3$  V DC  
 Calibration value VRAQ = 12 m/sec

Measured value: Duct velocity = 6.3 m/s

Air volume: Duct velocity x area  $m^2$  x 3600 =  $m^3/h$

## Volumetric flow controller VRAQ

### Room pressure control

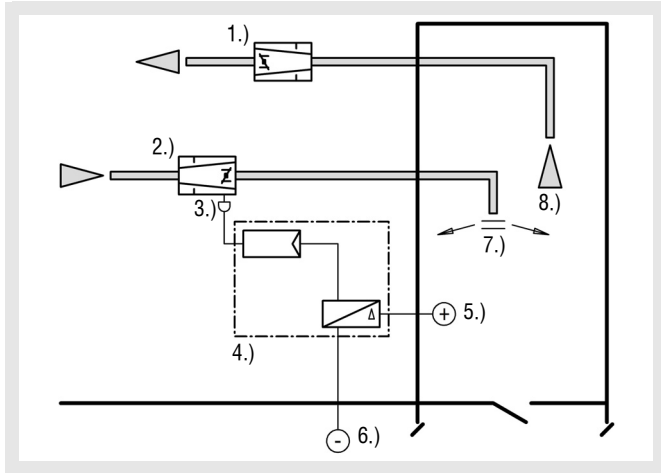

- 1.) Volumetric flow controller VRAQ with electric controller
- 2.) Damper DKA / HK / JK
- 3.) Actuator LMQ24A-VST
- 4.) Room pressure controller VRU-M1R-BAC
- 5.) Overpressure regulation, relative to the reference room
- 6.) Reference room
- 7.) Supply air
- 8.) return air

To maintain the required positive pressure, relative to a suitable reference room, the damper is used as room pressure controller on the supply air side, i.e., the pressure is controlled as a linear function and not as a function of the volumetric flow. The pressure difference between the room to be regulated and the reference room is measured by a static differential pressure sensor, which detects the pressure level and the sign (positive pressure or negative pressure). According to the pressure difference measured, the room pressure controller adjusts the control flap of the supply air volumetric flow controller via the actuator. The differential pressure sensor is connected to the room to be regulated and to the reference room via measuring pipes. In doing so, the maximum allowed hose length and the mounting position of the pressure sensor must be taken into account. A measuring probe (measuring cross) is not required.

As standard, the pressure regulator Belimo make type **VRU-M1R-BAC** is used for room pressure control together with the high-speed actuator type **LMQ24A-VST**. The room pressure can be set between -75 Pa and +75 Pa.

### Duct pressure control

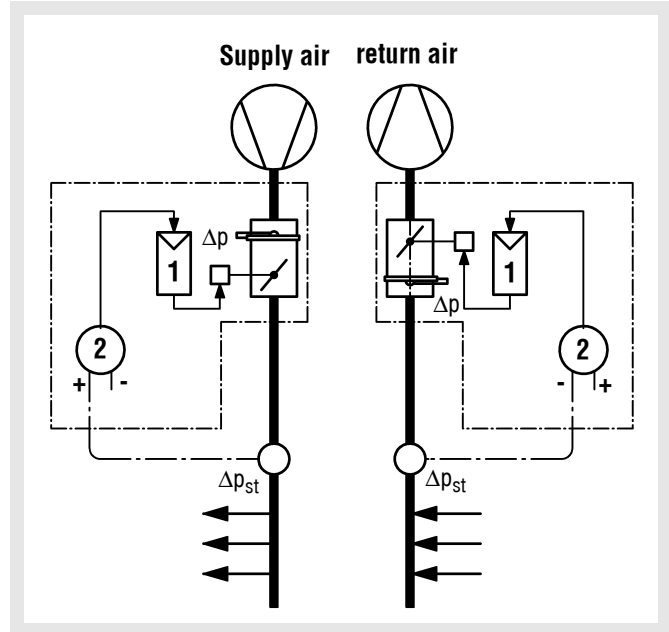

#### Duct pressure control in the supply air

- static pressure is measured **behind** the damper (in air flow direction)
- TARGET pressure is controlled (**over**pressure)
- connection "+" duct pressure
- connection "-" open

#### Duct pressure control in the return air

- static pressure is measured **in front of** the damper (in air flow direction)
- TARGET pressure is controlled (**negative** pressure)
- connection "-" duct pressure
- connection "+" open

As standard, the pressure controller Gruner make type 327VM-024-05-DS6-MB with an integrated sensor is used to control duct pressure. It has a measuring range of 0-600 Pa.

## Volumetric flow controller VRAQ

### Supply and return air volumetric flow control

#### Master/slave activation

#### for VRAQ with electric controller Belimo make

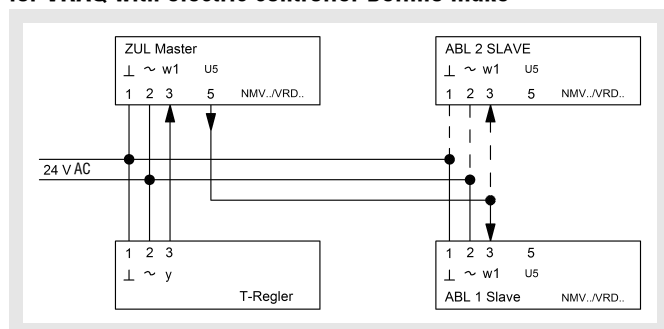

The slave is working sequentially to the master for:

- Installations with volumetric flow controllers in the supply air and return air that have to work sequentially.
- Supply and return air equipment of the same size.
- Regulation of the supply air/return air ratios.

The command signal  $w$  of the temperature controller is connected to the input of the supply air volumetric flow controller (master).

The actual value signal of the master is the drive signal for the return air volumetric flow controller (slave).

- The  $V_{\text{slave}}/V_{\text{master}}$  ratio is set with the  $V_{\text{max}}$  value of the slave. This value must be calculated.
- Set  $V_{\text{min}}$  slave to 0%.
- Apply the  $V_{\text{min}}$ ,  $V_{\text{max}}$  positive controls to the master only and the "Closed" one to the master and slave.

#### Parallel activation

#### for VRAQ with electric controller Belimo make

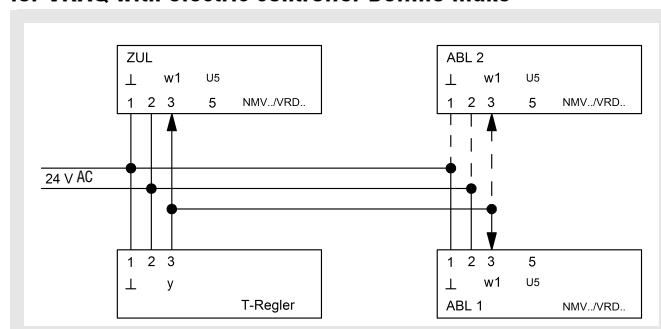

#### Wiring information

Connect  $U_5$  signal (actual value volumetric flow) always to a readily accessible terminal (switch cabinet, room controller). It is used to connect the setting device ZTH EU (see startup using the setting and diagnostic device ZTH EU).

The control operates for:

- Installations with parallel operation of volumetric flow controllers in supply air and return air (activated by the same command variable).
- Supply and return air installations of different sizes and settings of the minimum and maximum limits.
- Difference regulation between supply and return air.
- Installations with several supply and/or return air devices.

The command signal  $w$  of the temperature control is connected in parallel to the setpoint inputs of the supply and return air volumetric flow controllers VR...

The minimum and maximum limits of the volumetric flow must be set for each controller.

## Volumetric flow controller VRAQ

### Technical data of controllers and motors

#### Standard electric controller

##### LMV-D3-MP (make Belimo)

Dynamic pressure sensor, digital VAV controller and damper drive as communication-capable VAV-Compact solution.

Measuring principle:	Pressure reading with volumetric flow
Measuring range sensor:	-20... ~ 500 Pa
Supply voltage:	AC 24 V, 50/60 Hz; DC 24 V
Functional range:	AC 19.2...28.8 V / DC 21.6...28.8 V
Power consumption:	2 W
Dimensioning:	3.5 VA
Torque:	min. 5 Nm at the rated voltage
Control function:	VAV/CAV/Open-Loop; Supply/return air or stand-alone operation; master/slave parallel circuit; Mixing box control
Setting range $V_{\min}/V_{\max}$ :	$V_{\min} = 0...100$ % of set $V_{\text{nenn}}$ volumetric flow $V_{\max} = 20...100$ % of set $V_{\text{nenn}}$ volumetric flow
Command variable w/Y : (Input resistance min. 100 k $\Omega$ )	DC 2-10 V (4...20 mA with 500 $\Omega$ input resistance) DC 0-10 V (0...20 mA with 500 $\Omega$ input resistance) adjustable DC 0...10 V
Setting range actual value signal $U_5$ :	DC 2...10 V DC 0...10 V
MP bus function Address in bus mode:	1 ... 8 (traditional operation: PP)
KNX/MODBUS RTU/ BACnet:	with BELIMO gateway UK24MOD/-BAC, 1 ... 8 BELIMO MP devices (VAV / flap drive / valve)
DDC controller:	DDC controller / PLC from different manufacturers, with integrated MP interface
Sensor connection:	Passive (Pt1000, Ni1000, etc.) and active sensors (0...10 V), for example temperature, humidity, 2-point signal (switching power 16 mA @ 24 V), for example switch, presence detector
Protection class:	III (safety extra low voltage)
Degree of protection:	IP 54 (hose-connected)
EMC:	CE according to 39/336/EEC
Measuring air and ambient temperatures:	0 °C to +50 °C, 5-95% relative humidity, non-condensing
Storage temperature:	-20 °C to +80 °C
Sound power level:	max. 35 dB(A)
Operation and service:	plug-in via service socket / PC-Tool (from V3.1) / ZTH-EU
Communication:	PP/MP bus, max. DC 15V, 1200 baud
Connection:	Cable, 4 x 0.75mm <sup>2</sup> , terminals
Weight:	approx. 500 g

##### NMV-D3-MP (make Belimo)

Dynamic pressure sensor, digital VAV controller and damper drive as communication-capable VAV-Compact solution.

Measuring principle:	Pressure reading with volumetric flow
Measuring range sensor:	2... ~ 450 Pa
Supply voltage:	AC 24 V, 50/60 Hz, DC 24 V
Functional range:	AC 19.2...28.8 V / DC 21.6...28.8 V
Power consumption:	3 W
Dimensioning:	5 VA
Torque:	min. 10 Nm at the rated voltage
Control function:	VAV/CAV/Open-Loop; Supply/return air or stand-alone operation; master/slave parallel circuit; Mixing box control
Setting range $V_{\min}/V_{\max}$ :	$V_{\min} = 0...100$ % of set $V_{\text{nenn}}$ volumetric flow $V_{\max} = 20...100$ % of set $V_{\text{nenn}}$ volumetric flow
Command variable w/Y : (Input resistance min. 100 k $\Omega$ )	DC 2-10 V (4...20 mA with 500 $\Omega$ input resistance) DC 0-10 V (0...20 mA with 500 $\Omega$ input resistance) adjustable DC 0...10 V
Setting range actual value signal $U_5$ :	DC 2...10 V DC 0...10 V
MP bus function Address in bus mode:	MP 1 ... 8 (traditional operation: PP)
KNX/MODBUS RTU/ BACnet:	with BELIMO gateway UK24MOD/-BAC, 1 ... 8 BELIMO MP devices (VAV / flap drive / valve)
DDC controller:	DDC controller / PLC from different manufacturers, with integrated MP interface
Sensor connection:	Passive (Pt1000, Ni1000, etc.) and active sensors (0...10 V), for example temperature, humidity, 2-point signal (switching power 16 mA @ 24 V), for example switch, presence detector
Protection class:	III (safety extra low voltage)
Degree of protection:	IP 54 (hose-connected)
EMC:	CE according to 39/336/EEC
Measuring air and ambient temperatures:	0 °C to +50 °C, 5-95% relative humidity, non-condensing
Storage temperature:	-20 °C to +80 °C
Sound power level:	max. 35 dB(A)
Operation and service:	plug-in via service socket / PC-Tool (from V3.1) / ZTH-EU
Communication:	PP/MP bus, max. DC 15V, 1200 baud
Connection:	Cable, 4 x 0.75mm <sup>2</sup> , terminals
Weight:	approx. 700 g

## Volumetric flow controller VRAQ

### Standard electric controller

#### SMV-D3-MP (make Belimo)

Dynamic pressure sensor, digital VAV controller and damper drive as communication-capable VAV-Compact solution.

Measuring principle:	Pressure reading with volumetric flow
Measuring range sensor:	2... ~ 450 Pa
Supply voltage:	AC 24 V, 50/60 Hz, DC 24 V
Functional range:	AC 19.2...28.8 V / DC 21.6...28.8 V
Power consumption:	3 W
Dimensioning:	5.5 VA
Torque:	min. 20 Nm at the rated voltage
Control function:	VAV/CAV/Open-Loop; Supply/return air or stand-alone operation; master/slave parallel circuit; Mixing box control
Setting range $V_{min}/V_{max}$ :	$V_{min} = 0...100\%$ of set $V_{nenn}$ volumetric flow $V_{max} = 20...100\%$ of set $V_{nenn}$ volumetric flow
Command variable w/Y : (Input resistance min. 100 k $\Omega$ )	DC 2-10 V (4...20 mA with 500 $\Omega$ input resistance) DC 0-10 V (0...20 mA with 500 $\Omega$ input resistance) adjustable DC 0...10 V
Setting range actual value signal $U_5$ :	DC 2...10 V DC 0...10 V
MP bus function Address in bus mode:	MP1 ... 8 (traditional operation: PP)
KNX/MODBUS RTU/ BACnet:	with BELIMO gateway UK24MOD/-BAC, 1 ... 8 BELIMO MP devices (VAV / flap drive/ valve)
DDC controller:	DDC controller / PLC from different manufacturers, with integrated MP interface
Fan Optimiser:	with BELIMO Optimiser COU24-A-MP
Sensor connection :	Passive (Pt1000, Ni1000, etc.) and active sensors (0...10 V), for example temperature, humidity, 2-point signal (switching power 16 mA @ 24 V), for example switch, presence detector
Protection class:	III (safety extra low voltage)
Degree of protection:	IP 54 (hose-connected)
EMC:	CE according to 39/336/EEC
Measuring air and ambient temperatures:	0 °C to +50 °C, 5-95% relative humidity, non-condensing
Storage temperature:	-20 °C to +80 °C
Sound power level:	max. 45 dB(A)
Operation and service:	plug-in via service socket / PC-Tool (from V3.1) / ZTH-EU
Communication:	PP/MP bus, max. DC 15V, 1200 baud
Connection:	Cable, 4 x 0.75mm <sup>2</sup> , terminals
Weight:	approx. 830 g

### Alternative electric controller

#### VRU-D3-BAC (make Belimo)

Self-adapting digital volumetric flow/pressure controller, with integrated dynamic pressure sensor. Position-independent as a communication-capable universal solution with external actuators.

Measuring principle:	dynamic differential pressure measurement
Measuring range sensor:	2... ~500 Pa (bursting pressure +/- 10 kPa)
Sensor functional range:	0... ~500 Pa
Supply voltage:	AC 24 V, 50/60 Hz, DC 24 V
Functional range:	AC 19...29 V / DC 19...29 V
Power consumption:	1.5 W (without actuator)
Dimensioning:	2 VA (with VST actuator)
Control function:	VAV/CAV, STP (pressure), open loop Supply/return air or stand-alone operation; positive control; Master/slave or parallel circuit
Setting range: $V_{min}/V_{max}$ (volumetric flow)	$V_{min} = 0...100\%$ of $V_{nom}$ $V_{max} = 20...100\%$ of $V_{nom}$ $V_{kon.} = 0...100\%$ of $V_{nom}$
Setting range: $P_{min}$ to $P_{max}$ (pressure)	$P_{min} = 0...100\%$ of $P_{nom}$ $P_{max} = 20...100\%$ of $P_{nom}$ $P_{kon.} = 0...100\%$ of $P_{nom}$
Bus function:	BACnet MS/TP, Modbus RTU, MP bus
Command variable Y/Z: (inherent resistance min. 100 k $\Omega$ )	DC 0-10 V DC 2-10 V variable
Setting range: (actual value signal U)	DC 0-10 V DC 2-10 V variable
Sensor integration:	passive or active sensors (0-10V) for example, humidity, temperature 2-point signal (switching power 16 mA @ 24 V), for example switch, motion detector
Protection class:	III Safety extra-low voltage (SELV)
Degree of protection:	IP42 (measuring hoses and actuator connected)
Ambient temperature:	0 °C to +50 °C (environment), 5-95% relative humidity, non-condensing
Storage temperature:	-20 °C to +80 °C, 5-95% relative humidity, non-condensing
Operation and service:	via the ZTH EU setting device, Belimo Assistant app (NFC, Bluetooth) or via feedback signal/service plug with Belimo PC-Tool
Connection:	Terminals 2.5 mm <sup>2</sup>
Dimensions:	170 x 98 x 58 mm
Weight:	approx. 340 g
Maintenance:	maintenance-free

## Volumetric flow controller VRAQ

### Alternative electric controller

#### VRU-M1-BAC (make Belimo)

Self-adapting digital volumetric flow/pressure controller, with integrated static pressure sensor. Position-independent as a communication-capable universal solution with external actuators.

Measuring principle:	static differential pressure measurement
Measuring range sensor:	0... ~600 Pa (bursting pressure +/- 10 kPa)
Sensor functional range:	0... ~600 Pa
Supply voltage:	AC 24 V, 50/60 Hz, DC 24 V
Functional range:	AC 19...29 V / DC 19...29 V
Power consumption:	1.5 W (without actuator)
Dimensioning:	2 VA (with VST actuator)
Control function :	VAV/CAV, STP (pressure), open loop Supply/return air or stand-alone operation; positive control; master/slave or parallel circuit
Setting range: $V_{min}/V_{max}$ (volumetric flow)	$V_{min} = 0...100\%$ of $V_{nom}$ $V_{max} = 20...100\%$ of $V_{nom}$ $V_{kon.} = 0...100\%$ of $V_{nom}$
Setting range: $P_{min}$ to $P_{max}$ (pressure)	$P_{min} = 0...100\%$ of $P_{nom}$ $P_{max} = 20...100\%$ of $P_{nom}$ $P_{kon.} = 0...100\%$ of $P_{nom}$
Bus function:	BACnet MS/TP, Modbus RTU, MP bus
Command variable Y/Z: (inherent resistance min. 100 k $\Omega$ )	DC 0-10 V DC 2-10 V variable
Setting range: (actual value signal U)	DC 0-10 V DC 2-10 V variable
Sensor integration:	passive or active sensors (0-10V) for example, humidity, temperature 2-point signal (switching power 16 mA @ 24 V), for example switch, motion detector
Protection class:	III Safety extra-low voltage (SELV)
Degree of protection:	IP42 (measuring hoses and actuator connected)
Ambient temperature:	0 °C to +50 °C (environment), 5-95% relative humidity, non-condensing
Storage temperature:	-20 °C to +80 °C, 5-95% relative humidity, non-condensing
Operation and service:	via the ZTH EU setting device, Belimo Assistant app (NFC, Bluetooth) or via feedback signal/service plug with Belimo PC-Tool
Connection:	Terminals 2.5 mm <sup>2</sup>
Dimensions:	170 x 98 x 58 mm
Weight:	approx. 340 g
Maintenance:	maintenance-free

#### VRU-M1R-BAC (make Belimo)

Self-adapting digital room pressure controller, with integrated static pressure sensor. Position-independent as a communication-capable universal solution with external actuators.

Measuring principle:	static differential pressure measurement
Measuring range sensor:	-75... ~75 Pa (bursting pressure +/- 10 kPa)
Sensor functional range:	-75... ~75 Pa
Supply voltage:	AC 24 V, 50/60 Hz, DC 24 V
Functional range:	AC 19...29 V / DC 19...29 V
Power consumption:	1.5 W (without actuator)
Dimensioning:	2 VA (with VST actuator)
Control function :	room pressure, stand-alone operation; positive control; parallel circuit
Setting range: $P_{min}$ to $P_{max}$ (pressure)	$P_{min} = 0...100\%$ of $P_{nom}$ $P_{max} = 20...100\%$ of $P_{nom}$ $P_{kon.} = 0...100\%$ of $P_{nom}$
Bus function:	BACnet MS/TP, Modbus RTU, MP bus
Command variable Y/Z: (inherent resistance min. 100 k $\Omega$ )	DC 0-10 V DC 2-10 V variable
Setting range: (actual value signal U)	DC 0-10 V DC 2-10 V variable
Sensor integration:	passive or active sensors (0-10V) for example, humidity, temperature 2-point signal (switching power 16 mA @ 24 V), for example switch, motion detector
Protection class:	III Safety extra-low voltage (SELV)
Degree of protection:	IP42 (measuring hoses and actuator connected)
Ambient temperature:	0 °C to +50 °C (environment), 5-95% relative humidity, non-condensing
Storage temperature:	-20 °C to +80 °C, 5-95% relative humidity, non-condensing
Operation and service:	via the ZTH EU setting device, Belimo Assistant app (NFC, Bluetooth) or via feedback signal/service plug with Belimo PC-Tool
Connection:	Terminals 2.5 mm <sup>2</sup>
Dimensions:	170 x 98 x 58 mm
Weight:	approx. 340 g
Maintenance:	maintenance-free

## Volumetric flow controller VRAQ

### Alternative electric controller

#### GUAC-SM3/SCH (make Gruner)

Digital VAV controller, with static pressure sensor, position-independent als communication-capable universal solution.

Measuring principle:	static differential pressure measurement
Measuring range sensor:	0...~300 Pa (bursting pressure 1 bar)
Supply voltage:	AC 24 V, 50/60 Hz, DC 24 V
Functional range:	AC 19...29 V / DC 19...29 V
Power consumption:	0.5 W (without actuator)
Dimensioning:	1.5 VA (without actuator)
Control function:	VAV/CAV; Supply/return air or stand-alone operation; master/slave or parallel circuit
Setting range $V_{\min}$ to $V_{\max}$ :	$V_{\min} = 0...100\%$ of $V_{\text{nom}}$ $V_{\max} = 0...100\%$ of $V_{\text{nom}}$ $V_{\text{konst.}} = 0...100\%$ of $V_{\text{nom}}$
Command variable Y/Z: (Inherent resistance at least 100 k $\Omega$ )	DC 0-10 V (0-20 mA at least 500 $\Omega$ input resistance) DC 2-10 V (4-20 mA at least 500 $\Omega$ input resistance)
Setting range (actual value signal U/PP):	DC 0-10 V DC 2-10 V
DCC controller:	DCC controller or PLC
Sensor integration:	passive or active sensors (0-10V) for example, humidity, temperature 2-point signal (switching power 16 mA @ 24 V), for example switch, motion detector
Protection class:	III (Safety extra low voltage)
Degree of protection:	IP54 (measuring hoses connected)
Measuring air and ambient temp.:	0 °C to +70 °C (medium) 0 °C to +50 °C (environment), 5-95% relative humidity, non-condensing
Storage temperature:	-20 °C to +80 °C
Sound power level:	max. 35 dB(A)
Operation and service:	on the display, using a screwdriver directly at the device or via feedback signal/service plug using PC software
Connection:	cable 1000 mm, 4 x 0.75 mm <sup>2</sup> (halogen-free), terminals
Dimensions:	124 x 71.5 x 66.5 mm
Weight:	approx. 175 g
Maintenance:	maintenance-free

#### 327VM-024-05-MB (-10, -15) (make Gruner)

Dynamic pressure sensor, digital VAV controller as a communication-capable VAV-Compact solution.

Measuring principle:	Pressure reading with volumetric flow
Measuring range:	0...~500 Pa
Sensor:	(bursting pressure 1 bar) Supply voltage AC 24 V, 50/60 Hz, DC 24 V
Functional range:	AC 19...29 V / DC 19...29 V
Power consumption:	2.5 W (5 Nm)
Dimensioning:	4.0 VA (5 Nm)
Torque:	min. 5 Nm at the rated voltage (10 Nm, 15 Nm, optional)
Control function:	VAV/CAV/Open-Loop; supply/return air or stand-alone operation; master/slave parallel circuit; mixing box control
Setting range $V_{\min}$ to $V_{\max}$ :	$V_{\min} = 0...100\%$ of $V_{\text{nom}}$ $V_{\max} = 0...100\%$ of $V_{\text{nom}}$ $V_{\text{konst.}} = 0...100\%$ of $V_{\text{nom}}$
Command variable Y/Z: (Inherent resistance at least 100 k $\Omega$ )	DC 0-10 V (0-20 mA at least 500 $\Omega$ input resistance) DC 2-10 V (4-20 mA at least 500 $\Omega$ input resistance)
Setting range (actual value signal U/PP)	DC 0-10 V DC 2-10 V
Bus function:	PP bus (open PP protocol) Modbus RTU optional, Modbus RTU, hybrid mode
DCC controller:	DCC controller or PLC
Sensor integration:	passive or active sensors (0-10V) for example, humidity, temperature 2-point signal (switching power 16 mA @ 24 V), for example switch, motion detector
Protection class:	III (Safety extra low voltage)
Degree of protection:	IP54 (measuring hoses connected)
Measuring air and ambient temp.:	0 °C to +70 °C (medium) 0 °C to +50 °C (environment) 5-95% relative humidity, non-condensing
Storage temperature:	-20 °C to +80 °C
Sound power level:	max. 35 dB(A)
Operation and service:	plug-in via diagnostic plug to PC-Tool GUIV, manual setting device or feedback signal.
Communication:	Modbus RTU
Connection:	cable 1000 mm, 4 x 0.75 mm <sup>2</sup> (halogen-free), terminals
Dimensions:	115 x 65 x 61 mm
Weight:	approx. 550 g
Maintenance:	maintenance-free

## Volumetric flow controller VRAQ

### Alternative electric controller

#### 327VM-024-05-DS4-MB (-10, -15) (make Gruner)

Static pressure sensor, digital VAV and pressure controller as a communication-capable VAV-Compact solution

Measuring principle:	static pressure measurement (position-independent)
Measuring range sensor:	0...~300 Pa (bursting pressure 1 bar)
Supply voltage:	AC 24 V, 50/60 Hz, DC 24 V
Functional range:	AC 19...29 V / DC 19...29 V
Power consumption:	2.5 W (5 Nm)
Dimensioning:	4.0 VA (5 Nm)
Torque:	min. 5 Nm at the rated voltage (10 Nm, 15 Nm, optional)
Control function:	VAV/CAV/Open-Loop; pressure control, supply/return air or stand-alone operation; master/slave parallel circuit; mixing box control
Setting range $V_{min}$ to $V_{max}$ :	$V_{min} = 0...100\%$ of $V_{nom}$ $V_{max} = 0...100\%$ of $V_{nom}$ $V_{konst.} = 0...100\%$ of $V_{nom}$
Setting range $P_{min}$ to $P_{max}$ :	$P_{min} = 0...100\%$ of $P_{nom}$ $P_{max} = 0...100\%$ of $P_{nom}$ $P_{konst.} = 0...100\%$ of $P_{nom}$
Command variable Y/Z: (Inherent resistance at least 100 k $\Omega$ )	DC 0-10 V (0-20 mA at least 500 $\Omega$ input resistance) DC 2-10 V (4-20 mA at least 500 $\Omega$ input resistance)
Setting range: (actual value signal U/PP)	DC 0-10 V DC 2-10 V
Bus function:	Modbus RTU, hybrid mode
DCC controller:	DCC controller or PLC
Sensor integration:	passive or active sensors (0-10V) for example, humidity, temperature 2-point signal (switching power 16 mA @ 24 V), for example switch, motion detector
Protection class:	III (Safety extra low voltage)
Degree of protection:	IP54 (measuring hoses connected)
Measuring air and ambient temp.:	0 °C to +70 °C (medium) 0 °C to +50 °C (environment) 5-95% relative humidity, non-condensing
Storage temperature:	-20 °C to +80 °C
Sound power level:	max. 35 dB(A)
Operation and service:	Using the display by means of a screwdriver directly at the device or via the feedback signal.
Communication:	Modbus RTU
Connection:	cable 1000 mm, 4 x 0.75 mm <sup>2</sup> (halogen-free), terminals
Dimensions:	115 x 65 x 61 mm
Weight:	approx. 550 g
Maintenance:	maintenance-free

#### 327V-024-05-DS6-MB (-10, -15) (make Gruner)

Static pressure sensor, digital pressure controller as a communication-capable compact solution.

Measuring principle:	static pressure measurement (position-independent)
Measuring range sensor:	0...~600 Pa (bursting pressure 1 bar)
Supply voltage:	AC 24 V, 50/60 Hz, DC 24 V
Functional range:	AC 19...29 V / DC 19...29 V
Power consumption:	2.5 W (5 Nm)
Dimensioning:	4.0 VA (5 Nm)
Torque:	min. 5 Nm at the rated voltage (10 Nm, 15 Nm, optional)
Control function:	pressure control, open loop; supply/return air or stand-alone operation; master/slave parallel circuit;
Setting range $P_{min}$ to $P_{max}$ :	$P_{min} = 0...100\%$ of $P_{nom}$ $P_{max} = 0...100\%$ of $P_{nom}$ $P_{konst.} = 0...100\%$ of $P_{nom}$
Command variable Y/Z: (Inherent resistance at least 100 k $\Omega$ )	DC 0-10 V (0-20 mA at least 500 $\Omega$ input resistance) DC 2-10 V (4-20 mA at least 500 $\Omega$ input resistance)
Setting range: (actual value signal U/PP)	DC 0-10 V DC 2-10 V
Bus function:	Modbus RTU, hybrid mode
DCC controller:	DCC controller or PLC
Sensor integration:	passive or active sensors (0-10V) for example, humidity, temperature 2-point signal (switching power 16 mA @ 24 V), for example switch, motion detector
Protection class:	III (Safety extra low voltage)
Degree of protection:	IP54 (measuring hoses connected)
Measuring air and ambient temp.:	0 °C to +70 °C (medium) 0 °C to +50 °C (environment) 5-95% relative humidity, non-condensing
Storage temperature:	-20 °C to +80 °C
Sound power level:	max. 35 dB(A)
Operation and service:	plug-in via diagnostic plug to PC-Tool GUIV, manual setting device or feedback signal.
Communication:	Modbus RTU
Connection:	cable 1000 mm, 4 x 0.75 mm <sup>2</sup> (halogen-free), terminals
Dimensions:	115 x 65 x 61 mm
Weight:	approx. 550 g
Maintenance:	maintenance-free

## Volumetric flow controller VRAQ

### Alternative electric controller

#### GLB181.1E/3 (make Siemens)

Digital VAV controller, with dynamic pressure sensor and integrated actuator, position-independent as a communication-capable VAV-Compact solution.

Measuring principle:	Pressure sensor for dynamic measurement of the effective pressure, automatic zero point calibration
Measuring range sensor:	0...~500 Pa measuring range, 0...~300 Pa operating range (bursting pressure 1 bar)
Supply voltage:	AC 24 V, 50/60 Hz, DC 24 V, $\pm 20\%$
Functional range:	AC 19...29 V / DC 19...29 V
Torque:	min. 10 Nm at the rated voltage
Power consumption:	5.5 W (drive rotating) 0.5 W (stopping state)
Dimensioning:	7.5 VA (drive rotating) 1.0 VA (stopping state)
Control function:	VAV/CAV, open loop, Supply/return air or stand-alone operation; positive control; master/slave or parallel circuit
Setting range $V_{\min}/V_{\max}$ :	$V_{\min} = -20...100\%$ of $V_{\text{nom}}$ $V_{\max} = 20...100\%$ of $V_{\text{nom}}$
Setting range Command variable YC:	DC 0-10 V DC 2-10 V
Setting range Actual value signal U:	DC 0-10 V DC 2-10 V
Running time:	150 sec. for 90° angle of rotation
DCC controller:	DCC controller or PLC
Sensor integration:	passive or active sensors (0-10V)
Protection class:	III (Safety extra low voltage)
Degree of protection:	IP54 (measuring hoses connected)
Measuring air and ambient temperatures:	0 °C to +50 °C, 5-95% relative humidity, non-condensing
Storage temperature:	-25 °C to +70 °C
Operation and service:	via service socket with PC software ACS941 or AST 10 manual setting device
Connection:	cable 900 mm, 6 x 0.75 mm <sup>2</sup> (halogen-free)
Dimensions:	158 x 71 x 61 mm
Weight:	approx. 600 g
Maintenance:	maintenance-free

#### GDB181.1E/KN (make Siemens)

Digital VAV controller, with dynamic pressure sensor and integrated actuator, position-independent as a communication-capable VAV-Compact solution with KNX.

Measuring principle:	Pressure sensor for dynamic measurement of the effective pressure, automatic zero point calibration
Measuring range sensor:	0...~500 Pa measuring range, 0...~300 Pa operating range (bursting pressure 1 bar)
Supply voltage:	AC 24 V, 50/60 Hz, DC 24 V, $\pm 20\%$
Functional range:	AC 19...29 V / DC 19...29 V
Torque:	min. 5 Nm at the rated voltage
Power consumption:	2.5 W (drive rotating) 0.5 W (stopping state)
Dimensioning:	3.0 VA (drive rotating) 1.0 VA (stopping state)
Control function:	VAV/CAV, open loop, Supply/return air or stand-alone operation; positive control;
Setting range $V_{\min}/V_{\max}$ :	$V_{\min} = -20...100\%$ of $V_{\text{nom}}$ $V_{\max} = 20...100\%$ of $V_{\text{nom}}$
Setting range Command variable YC:	KNX bus
Setting range Actual value signal U:	KNX bus
Running time:	150 sec. for 90° angle of rotation
Protection class:	III (Safety extra low voltage)
Degree of protection:	IP54 (measuring hoses connected)
Measuring air and ambient temperatures:	0 °C to +50 °C (medium), 0 °C to +50 °C (environment), 5-95% relative humidity, non-condensing
Storage temperature:	-25 °C to +70 °C
Operation and service:	via service socket with PC software ACS941 or AST 10 manual setting device
Connection:	cable 900 mm, 2 x 2 x 0.75 mm <sup>2</sup> (halogen-free)
Dimensions:	158 x 71 x 61 mm
Weight:	approx. 600 g
Maintenance:	maintenance-free

## Volumetric flow controller VRAQ

### Alternative electric controller

#### GLB181.1E/KN (make Siemens)

Digital VAV controller, with dynamic pressure sensor and integrated actuator, position-independent as a communication-capable VAV-Compact solution with KNX.

Measuring principle:	Pressure sensor for dynamic measurement of the effective pressure, automatic zero point calibration
Measuring range sensor:	0...~500 Pa measuring range, 0...~300 Pa operating range (bursting pressure 1 bar)
Supply voltage:	AC 24 V, 50/60 Hz, DC 24 V, $\pm 20\%$
Functional range:	AC 19...29 V / DC 19...29 V
Torque:	min. 10 Nm at the rated voltage
Power consumption:	5.5 W (drive rotating) 0.5 W (stopping state)
Dimensioning:	7.5 VA (drive rotating) 1.0 VA (stopping state)
Control function:	VAV/CAV, open loop, Supply/return air or stand-alone operation; positive control;
Setting range $V_{\min}/V_{\max}$ :	$V_{\min} = -20...100\%$ of $V_{\text{nom}}$ $V_{\max} = 20...100\%$ of $V_{\text{nom}}$
Setting range Command variable YC:	KNX bus
Setting range Actual value signal U:	KNX bus
Running time:	150 sec. for 90° angle of rotation
Protection class:	III (Safety extra low voltage)
Degree of protection:	IP54 (measuring hoses connected)
Measuring air and ambient temperatures:	0 °C to +50 °C (medium), 0 °C to +50 °C (environment), 5-95% relative humidity, non-condensing
Storage temperature:	-25 °C to +70 °C
Operation and service:	via service socket with PC software ACS941 or AST 10 manual setting device
Connection:	cable 900 mm, 2 x 2 x 0.75 mm <sup>2</sup> (halogen-free)
Dimensions:	158 x 71 x 61 mm
Weight:	approx. 600 g
Maintenance:	maintenance-free

#### DVC-V322A / DVC-V322AF (make Delta Controls)

Freely programmable Advanced Application Controller (B-AAC), with static pressure sensor and actuator, as a communication-capable VAV-Compact solution.

Measuring principle:	Pressure sensor for static effective pressure measurement
Measuring range sensor:	2... ~ 250 Pa operating range (bursting pressure 1 bar)
Supply voltage:	AC 24 V, 50 Hz, $\pm 20\%$
Functional range:	AC 19...29 V; DC 19...29 V
Power consumption:	2.5 W (drive rotating)
Dimensioning:	15 VA (32 VA with fully loaded TRIAC outputs)
Torque:	min. 5 Nm at the rated voltage
Control function:	VAV/CAV; Supply/return air or stand-alone operation; positive control
Setting range $V_{\min}$ to $V_{\max}$ :	$V_{\min} = 0...100\%$ of $V_{\text{nom}}$ $V_{\max} = 20...100\%$ of $V_{\text{nom}}$
Running time:	150 sec. for 90° angle of rotation
Inputs:	2 Universal inputs, 10-bit resolution (0-5 V, 0-10 V, 10 K..., 4-20 mA, potential-free contacts) 1 input 10-bit resolution (10 K $\Omega$ , potential-free contacts)
Outputs:	2 binary TRIAC outputs 2 analogue outputs (0-10 V DC, 8 bit) LED status display for each output
Protection class:	III (Safety extra low voltage)
Measuring air and ambient temperatures:	0 °C to +50 °C, 10-90% relative humidity, non-condensing
Storage temperature:	-25 °C to +70 °C
Sound power level:	max. 35 dB(A)
Operation and service:	via service socket with PC software
Communications connections:	RS-485 Main LAN (NET1) BACnet MS/TP @ 9600, 19200, 38400 or 76800 bps (standard) a maximum of 99 devices per BACnet MS/TP Subnet segment RS-485 Sub LAN (NET2) Delta LINKnet @ 76800 bps a maximum of 4 devices on the LINKnet with no more than 2 DFM/DNT devices
Dimensions:	239 x 120 x 80 mm
Weight:	approx. 840 g
Maintenance:	maintenance-free

## Volumetric flow controller VRAQ

### Standard pneumatic controller

#### RLP100 F003 (make Sauter)

Pneumatic integral volumetric flow controller in connection with a damper drive with control flap and a measuring sensor for use with fixed, switchover and variable control

Measuring principle:	High-precision, static differential pressure sensor
Measuring range sensor:	1...160 Pa
Feed pressure:	1.3 bar +/- 0.1 bar
Air consumption:	44 l/h
Air flow pressure:	0.2...1.0 bar
Response sensitivity:	0.1 Pa
Allowed ambient temperature:	0 °C to +55 °C
Degree of protection:	IP 30
Control direction:	Depressurised CLOSED/OPEN (B/A)
Conforms to EN 13463-1 and EN 1127-1 (Ex II 2 G T6) and for use in potentially explosive atmospheres of Zone 1.	

For supply and return air (integral room air control system)

### Alternative pneumatic controller

#### RLP100 F914 (make Sauter)

Pneumatic integral volumetric flow controller in connection with a damper drive with control flap and a measuring sensor for use with fixed, switchover and variable control Can be used if air

Measuring principle:	High-precision, static differential pressure sensor
Measuring range sensor:	1...160 Pa
Feed pressure:	1.3 bar +/- 0.1 bar
Air consumption:	44 l/h
Air flow pressure:	0.2...1.0 bar
Response sensitivity:	0.1 Pa
Allowed ambient temperature:	0 °C to +55 °C
Degree of protection:	IP 30
Control direction:	Depressurised OPEN (A)
Conforms to EN 13463-1 and EN 1127-1 (Ex II 2 G T6) and for use in potentially explosive atmospheres of Zone 1.	

contains aggressive media.

For return air with aggressive gases (integral room air control system)

## Volumetric flow controller VRAQ

**Damper actuators ...24A-VST (make BELIMO)  
for VRU-...-BAC**

### LM24A-VST

Actuator, communicative, with position feedback

Supply voltage:	AC 24 V, 50/60 Hz, DC 24 V, ready to plug in
Functional range:	AC 19.2-28.8 V / DC 21.6-28.8 V
Power consumption:	1 W (during operation)
Dimensioning:	2 VA
Torque:	5 Nm (at the rated voltage)
Running time for 90° (or 95°):	120 sec.
Activation:	communicative PP
Protection class:	III Safety extra-low voltage (SELV)
Degree of protection:	IP 54
Ambient temperature:	-30 °C to 50 °C, 5-95% relative humidity, non-condensing
Storage temperature:	-40 °C to +80 °C
Sound power level:	max. 35 dB(A)
Manual adjustment:	Gears are disengaged by pushbutton, self-restoring
Connection:	cable 500 mm with VST plug
Dimensions:	116 x 66 x 61 mm
Weight:	approx. 560 g
Maintenance:	maintenance-free

### NM24A-VST

Actuator, communicative, with position feedback

Supply voltage:	AC 24 V, 50/60 Hz, DC 24 V, ready to plug in
Functional range:	AC 19.2-28.8 V / DC 21.6-28.8 V
Power consumption:	2 W (during operation)
Dimensioning:	4 VA
Torque:	10 Nm (at the rated voltage)
Running time for 90° (or 95°):	120 sec.
Activation:	communicative PP
Protection class:	III Safety extra-low voltage (SELV)
Degree of protection:	IP 54
Ambient temperature:	-30 to +50 °C, 5-95% relative humidity, non-condensing
Storage temperature:	-40 °C to +80 °C
Sound power level:	max. 35 dB(A)
Manual adjustment:	Gears are disengaged by pushbutton, self-restoring
Connection:	cable 500 mm with VST plug
Dimensions:	124 x 80 x 62 mm
Weight:	approx. 780 g
Maintenance:	maintenance-free

### SM24A-VST

Actuator, communicative, with position feedback.

Supply voltage:	AC 24 V, 50/60 Hz, DC 24 V, ready to plug in
Functional range:	AC 19.2-28.8 V / DC 21.6-28.8 V
Power consumption:	2 W (during operation)
Dimensioning:	4 VA
Torque:	20 Nm (at the rated voltage)
Running time for 90°:	120 sec.
Activation:	communicative PP
Protection class:	III Safety extra-low voltage (SELV)
Degree of protection:	IP54
Ambient temperature:	-30 °C to 50 °C, 5-95% relative humidity, non-condensing
Storage temperature:	-40 °C to +80 °C
Sound power level:	max. 45 dB(A)
Manual adjustment:	Gears are disengaged by pushbutton, self-restoring
Connection:	cable 500 mm with VST plug
Dimensions:	139 x 88 x 64 mm
Weight:	approx. 980 g
Maintenance:	maintenance-free

### NF24A-VST

Spring return actuator with emergency control function, communicative, with position feedback.

Supply voltage:	AC 24 V, 50/60 Hz, DC 24 V, ready to plug in
Functional range:	AC 19.2-28.8 V / DC 21.6-28.8 V
Power consumption:	5 W (in motion)
Dimensioning:	8 VA
Torque:	10 Nm (at the rated voltage)
Spring torque:	10 Nm
Running time for 90°:	120 sec. (motor) < 20 sec. (spring)
Activation:	communicative PP
Protection class:	III Safety extra-low voltage (SELV)
Degree of protection:	IP54
Ambient temperature:	-30 °C to +50 °C, 5-95% relative humidity, non-condensing
Storage temperature:	-40 °C to +80 °C
Sound power level:	max. 40 dB(A) (motor)
Manual adjustment:	Manual winding with lock
Connection:	cable 500 mm with VST plug
Dimensions:	214 x 98 x 93 mm
Weight:	approx. 2300 g
Maintenance:	maintenance-free

## Volumetric flow controller VRAQ

### SF24A-VST

Spring return actuator with emergency control function, communicative, with position feedback.

Supply voltage:	AC 24 V, 50/60 Hz, DC 24 V, ready to plug in
Functional range:	AC 19.2-28.8 V / DC 21.6-28.8 V
Power consumption:	8.5 W (in motion)
Dimensioning:	11 VA
Torque:	20 Nm (at the rated voltage)
Spring torque:	20 Nm
Running time for 90°:	120 sec. (motor) < 20 sec. (spring)
Activation:	communicative PP
Protection class:	III Safety extra-low voltage (SELV)
Degree of protection:	IP54
Ambient temperature:	-30 °C to +50 °C, 5-95% relative humidity, non-condensing
Storage temperature:	-40 °C to +80 °C
Sound power level:	max. 40 dB(A) (motor)
Manual adjustment:	Manual winding with lock
Connection:	cable 500 mm with VST plug
Dimensions:	214 x 98 x 93 mm
Weight:	approx. 2300 g
Maintenance:	maintenance-free

### NMQ24A-VST

High-speed actuator, communicative, with position feedback

Supply voltage:	AC 24 V, 50/60 Hz, DC 24 V, ready to plug in
Functional range:	AC 19.2-28.8 V / DC 21.6-28.8 V
Power consumption:	13 W (during operation)
Dimensioning:	23 VA
Torque:	8 Nm (at the rated voltage)
Running time for 90°:	4 sec.
Activation:	communicative PP
Protection class:	III Safety extra-low voltage (SELV)
Degree of protection:	IP 54
Ambient temperature:	-30 °C to +50 °C, 5-95% relative humidity, non-condensing
Storage temperature:	-40 °C to +80 °C
Sound power level:	max. 56 dB(A)
Manual adjustment:	Gears are disengaged by pushbutton, self-restoring
Connection:	cable 500 mm with VST plug
Dimensions:	139 x 88 x 77 mm
Weight:	approx. 780 g
Maintenance:	maintenance-free

### NKQ24A-VST

High-speed actuator with emergency control function, communicative, with position feedback

Supply voltage:	AC 24 V, 50/60 Hz, DC 24 V, ready to plug in
Functional range:	AC 19.2-28.8 V / DC 21.6-28.8 V
Power consumption:	11 W (during operation)
Dimensioning:	22 VA
Torque:	6 Nm (at the rated voltage)
Running time for 90°:	4 sec. (motor) 4 sec. (emergency control)
Emergency position setting	0...100% in 10% steps
Precharge time:	approx. 15 sec.
Activation:	communicative PP
Protection class:	III Safety extra-low voltage (SELV)
Degree of protection:	IP 54
Ambient temperature:	-30 °C to +50 °C, 5-95% relative humidity, non-condensing
Storage temperature:	-40 °C to +80 °C
Sound power level:	max. 60 dB(A)
Manual adjustment:	Gears are disengaged by pushbutton, self-restoring
Connection:	cable 500 mm with VST plug
Dimensions:	139 x 88 x 80 mm
Weight:	approx. 1400 g
Maintenance:	maintenance-free

### LMQ24A-VST

High-speed actuator, communicative, with position feedback

Supply voltage:	AC 24 V, 50/60 Hz, DC 24 V, ready to plug in
Functional range:	AC 19.2-28.8 V / DC 21.6-28.8 V
Power consumption:	13 W (during operation)
Dimensioning:	23 VA
Torque:	4 Nm (at the rated voltage)
Running time for 90°:	2.5 sec.
Activation:	communicative PP
Protection class:	III Safety extra-low voltage (SELV)
Degree of protection:	IP54
Ambient temperature:	-30 °C to +50 °C, 5-95% relative humidity, non-condensing
Storage temperature:	-40 °C to +80 °C
Sound power level:	max. 54 dB(A)
Manual adjustment:	Gears are disengaged by pushbutton, self-restoring
Connection:	cable 500 mm with VST plug
Dimensions:	124 x 80 x 75 mm
Weight:	approx. 560 g
Maintenance:	maintenance-free

## Volumetric flow controller VRAQ

**Damper drives...24-** (make Gruner)  
for **GUAC-SM3/SCH**

### 341C-024-05-V

Spring return actuator

Supply voltage:	AC 24 V, 50/60 Hz, DC 24 V, ready to plug in
Functional range:	AC 19...29 V / DC 19...29 V
Power consumption:	5 W (in motion)
Dimensioning:	6.5 VA
Torque:	> 5 Nm (at the rated voltage)
Spring torque:	>5 Nm
Running time for 90°:	< 100 sec. (motor) < 20 sec. (spring)
Activation:	6 ± 4 V DC (from GUAC)
Protection class:	III (safety extra low voltage)
Degree of protection:	IP 54
Ambient temperature:	-30 °C to +50 °C, 5-95% relative humidity, non-condensing
Storage temperature:	-30 °C to +80 °C
Sound power level:	< 35 dB(A) (motor) < 65 dB(A) (spring)
Manual adjustment:	Manual winding with lock
Connection:	Cable 1000mm with Phönix plug
Dimensions:	145 x 75 x 70 mm
Weight:	approx. 1200 g
Maintenance:	maintenance-free

### 361C-024-10-V

Spring return actuator

Supply voltage:	AC 24 V, 50/60 Hz, DC 24 V, ready to plug in
Functional range:	AC 19...29 V / DC 19...29 V
Power consumption:	5 W (in motion)
Dimensioning:	8 VA
Torque:	> 10 Nm (at the rated voltage)
Spring torque:	> 10 Nm
Running time for 90°:	< 150 sec. (motor) < 20 sec. (spring)
Activation:	6 ± 4 V DC (from GUAC)
Protection class:	III (safety extra low voltage)
Degree of protection:	IP 54
Ambient temperature:	-30 °C to +50 °C, 5-95% relative humidity, non-condensing
Storage temperature:	-30 °C to +80 °C
Sound power level:	< 35 dB(A) (motor) < 65 dB(A) (spring)
Manual adjustment:	Manual winding with lock
Connection:	Cable 1000mm with Phönix plug
Dimensions:	193 x 96 x 60 mm
Weight:	approx. 1800 g
Maintenance:	maintenance-free

### 328CS-024-05B-V

High-speed actuator, with position feedback

Supply voltage:	AC 24 V, 50/60 Hz, DC 24 V, ready to plug in
Functional range:	AC 19...29 V / DC 19...29 V
Power consumption:	11 W (in motion)
Dimensioning:	15 VA
Torque:	> 5 Nm (at the rated voltage)
Running time for 90°:	2 sec.
Activation:	6 ± 4 V DC (from GUAC)
Protection class:	III (safety extra low voltage)
Degree of protection:	IP 54
Ambient temperature:	-30 °C to +50 °C, 5-95% relative humidity, non-condensing
Storage temperature:	-30 °C to +80 °C
Sound power level:	< 55 dB(A)
Manual adjustment:	Gears are disengaged by pushbutton, self-restoring
Connection:	Cable 1000mm with Phönix plug
Dimensions:	172.5 x 65 x 90 mm
Weight:	approx. 790 g
Maintenance:	maintenance-free

### 328CS-024-10B-V

High-speed actuator, with position feedback

Supply voltage:	AC 24 V, 50/60 Hz, DC 24 V, ready to plug in
Functional range:	AC 19...29 V / DC 19...29 V
Power consumption:	18 W (in motion)
Dimensioning:	22 VA
Torque:	> 10 Nm (at the rated voltage)
Running time for 90°:	3 sec.
Activation:	6 ± 4 V DC (from GUAC)
Protection class:	III (safety extra low voltage)
Degree of protection:	IP 54
Ambient temperature:	-30 °C to +50 °C, 5-95% relative humidity, non-condensing
Storage temperature:	-30 °C to +80 °C
Sound power level:	< 55 dB(A)
Manual adjustment:	Gears are disengaged by pushbutton, self-restoring
Connection:	Cable 1000mm with Phönix plug
Dimensions:	172.5 x 65 x 90 mm
Weight:	approx. 790 g
Maintenance:	maintenance-free

## Volumetric flow controller VRAQ

### Functional check

#### NMV-D3-MP and LMV-D3-MP:

##### Functional check

##### Electrical connection

Apply supply voltage 24 V AC ( $\pm 10\%$ ) to terminals 1+2.

Is the polarity of system neutral conductor correct?

⇒ **No:** Check the wiring according to the diagram. Check transformer power.

→ NMV-D3-MP 5.5 VA / LMV-D3-MP 5 VA

⇒ **Yes:** **NMV-D3-MP / ZTH EU or LMV-D3-MP / ZTH EU**

↓

#### NMV-D3-MP / ZTH EU or LMV-D3-MP / ZTH EU:

Has the NMV-D3-MP / LMV-D3-MP been set to the correct operating mode?

(Check using the connected setting device ZTH EU!)

⇒ **No:** Set operating mode using ZTH EU.

→ Operating modes: 0-10 V, 2-10 V

⇒ **Yes:** **Drive**

↓

#### Drive:

Use the ZTH-EU to set operating mode 2-10 V and connect terminals 1+3 of the NMW-D3-MP / LMV-D3-MP.

Does the drive move to the "CLOSED" position?

⇒ **No:** Contact VRAQ manufacturer

⇒ **Yes:**  $V_{\max}$

↓

#### $V_{\max}$ :

Connect the terminals 2+3 of the NMV-D3-MP / LMV-D3-MP.

Does the NMV-D3-MP / LMV-D3-MP control to  $V_{\max}$ ? - Check actual value signal  $U_5$ .

⇒ **No:** Check  $V_{\max}$  value in the ZTH EU and compare settings with the technical data on the VAV machine.

→ If the drive moves to the "OPEN" position, and the maximum volume is not reached, then the duct pressure is too low.

⇒ **Yes:** Use ZTH EU to set the system-specific operating mode.

#### Functional check during startup and service

If required, easily accessible setting potentiometers and connections allow set values and the correct operation of the volumetric flow controllers to be reliably and quickly checked on-site.

## Volumetric flow controller VRAQ

### Startup using PC-Tool

Direct connection in the switch cabinet or socket  
(traditional application)

#### ZTH EU as MP level converter



#### Description

The ZTH EU is also a potential-free interface between the USB port of a PC and the Belimo MP bus. It is used to connect the Belimo PC-Tool directly to the MP bus or directly to a programmable MFT drive.

#### Power supply

The ZTH EU is supplied with power by the USB port. The MP bus voltage is obtained internally by means of DC/DC converter. This is why no external power supply is necessary.

#### Driver

To be able to work with the ZTH EU, a suitable driver must be installed on the PC. The driver can be downloaded from the Belimo website (download section). After installation of the driver, the ZTH EU device will log in to the PC as a virtual COM interface.

#### Note

For connection to USB ports of PCs and BELIMO 24 V drives only (to safety extra low voltage SELV or US class 2 feeds).

#### Connection diagram 1

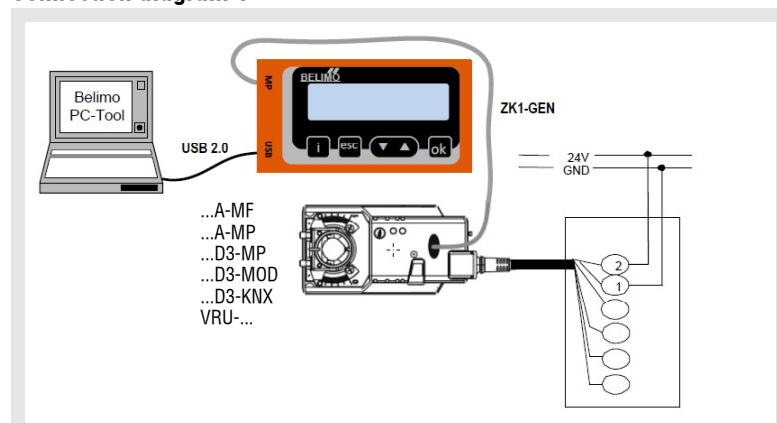

Local connection via a service socket of the MF/MP or LON drive using a ZK1-GEN cable.

#### Connection diagram 2

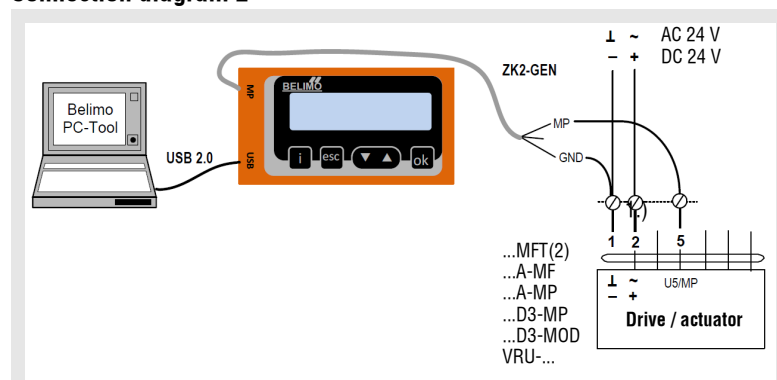

Local connection via a connecting cable of the MF/MP or LON drive using a ZK2-GEN cable.

- 1.) white = GND
- green = MP
- blue = not connected

## Volumetric flow controller VRAQ

### Startup using the setting and diagnostic device ZTH EU (Belimo)



#### Brief description

The VAV setting device ZTH EU allows efficient testing of VAV and CAV installations. Installations fitted with the Belimo VAV controller can be simply adapted to the room and user requirements.

The VAV setting device ZTH EU replaces the previous setting device ZTH-GEN (2007-2014).

All standard Belimo VAV controllers with integrated PP communication (from 1992) that are sold in the EU can be set using the ZTH EU.

#### Specifications:

- easy, quick setting of the VAV boxes parameters
- diagnostic function
- one tool for all VAV units
- voltage supplied by VAV controllers - no batteries required!
- service socket VAV / CR24 controller, PP connection
- includes connecting cable RJ12 6/4, 6-pin plug
- New generation, MP bus tester
- for functional test of MP bus
- backward compatible with all Belimo PP / MP units from 1992
- efficient handling, can be operated with one hand
- Selection of stages for test (OPEN/CLOSE/MIN/MAX/STOP)
- Damper position indicator for diagnostics
- Display of the setpoint / actual volume and  $V_{min/max}$  setting in  $m^3/s$  (l/s).

#### Operating element:

##### LCD display:

- Backlight
- Display with 2 x 16 digits



##### Key function:

- ▲▼ Forwards / backwards, change value / status
- ok Confirm input / switch to the submenu
- esc Cancel input / Leave submenu / Discard changes
- i shows additional information (if available)

#### Connection:

Locally via service socket



#### Dimensions:

85x65x23 (WxHxD)

#### Connection and supply

Stand-alone operation:

Connection including supply takes place via the service socket at the VAV controller or via the terminals.

Bus operation:

The ZTH EU can be used in the following units while the bus is running if it is connected via the local service socket: L/NMV-D3-MP.

With the VRP-M and L/NMV-D3M, the MP-Bus must be disconnected when the service socket is used.

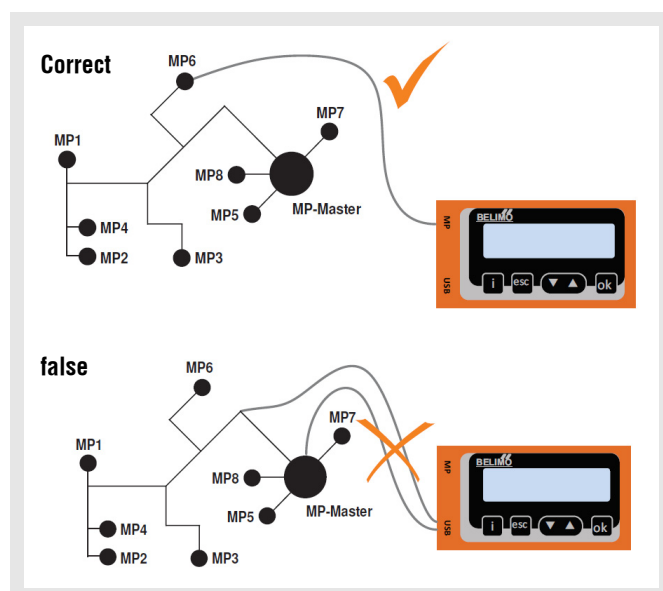

#### Restriction:

Direct connection in an MP network or via an MP bus master is not possible.

The ZTH EU comes with a quick start guide de/en to be affixed to the back of the unit.

## Volumetric flow controller VRAQ

### Smartphone - Belimo Assistant App

The NFC antenna area of the VAV Compact is located between the Belimo or OEM logo and the NFC label.

Align NFC-capable android smartphone with loaded Assistant app on the VAV-Compact such that the two antennae are above one another.

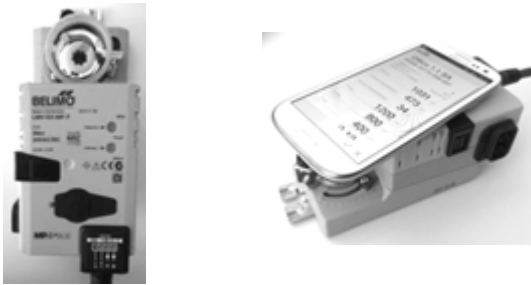

The Belimo Assistant app can be downloaded from the Google Play Store.

#### NFC-capable devices:

- L/NMV-D3-MP with printed NFC label
- VRU-...

#### Non-NFC-capable devices:

- All devices without NFC label
- L/NMV-D3-MF

### Startup using the setting device GUIV-A

#### Application

The setting device GUIV-A is used by the startup or service personnel in order to carry out simple settings to the equipment or to check the actual values.

The controller type 227V does not have any operating elements such as switches or setpoint potentiometers. To program the operating modes and the operating parameters  $V_{\min}$  and  $V_{\max}$ , the setting device GUIV-A is required, which can also be used to switch from 2 - 10 V DC to 0 - 10 V DC.

#### Connection

The GUIV-A can be connected electrically to 227 V via the U/PP connection by direct on-site or remote control, for example in a switch cabinet.

#### Structure and operation

The relevant parameters can be set and queried in the individual menu items, while the operating parameters programmed in-factory can be queried under menu item 10.

#### Note:

As long as the U/PP connector is connected to the GUIV-A, the output signal U does not correspond to the actual value.

#### Connection diagram

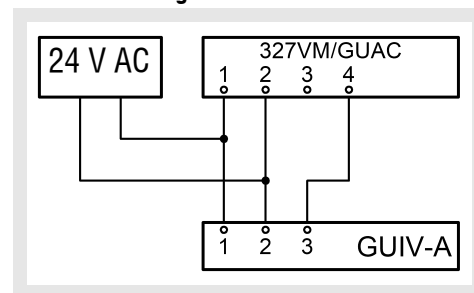

- 1 Earth, neutral
- 2 Supply voltage 24 V AC
- 3 Setpoint value signal Y and positive control Z input 227V, GUAC
- 4 Output communication signal PP and actual volumetric flow U

## Volumetric flow controller VRAQ

### Controller selection

The selection of each actuator (torque) depends on the housing dimensions. The actuator is already selected and mounted at the factory.

Electric controller - standard				
Controller	Actuator	DM	AN	AG
- Belimo :				
- LMV-D3-MP	Compact	5 Nm	-	-A003
- NMV-D3-MP	Compact	10 Nm	-	-A004
- SMV-D3-MP	Compact	20 Nm	-	-A005

Electric controller - alternative				
Controller	Actuator	DM	AN	AG
- Belimo :				
- VRU-D3-BAC	LM24A-VST	5 Nm	-	-A142
	NM24A-VST	10 Nm	-	-A143
	SM24A-VST	20 Nm	-	-A144
	LMQ24A-VST	4 Nm	SL	-A145
	NMQ24A-VST	8 Nm	SL	-A146
	NKQ24A-VST	8 Nm	SR	-A147
	NF24A-VST	10 Nm	FR	-A148
	SF24A-VST	20 Nm	FR	-A149
- VRU-M1-BAC	LM24A-VST	5 Nm	-	-A150
	NM24A-VST	10 Nm	-	-A151
	SM24A-VST	20 Nm	-	-A152
	LMQ24A-VST	4 Nm	SL	-A153
	NMQ24A-VST	8 Nm	SL	-A154
	NKQ24A-VST	8 Nm	SR	-A155
	NF24A-VST	10 Nm	FR	-A156
	SF24A-VST	20 Nm	FR	-A157
- VRU-M1R-BAC	LMQ24A-VST	4 Nm	SL	-A158
	NMQ24A-VST	8 Nm	SL	-A159
- Delta Controls :				
- DVC-V322A	Siemens	5 Nm	-	-A087
- DVC-V322AF	Siemens	5 Nm	-	-A088
- Gruner :				
- GUAC-SM3/SCH	341C-024-05-V	5 Nm	FR	-A068
	361C-024-10-V	10 Nm	FR	-A069
	328CS-024-05B-V/ST06	5 Nm	SL	-A070
	328CS-024-10B-V/ST06	10 Nm	SL	-A071
- GUAC-PM3/SCH	341C-024-05-V	5 Nm	FR	-A072
	361C-024-10-V	10 Nm	FR	-A073
	328CS-024-05B-V/ST06	5 Nm	SL	-A074
	328CS-024-10B-V/ST06	10 Nm	SL	-A075
- GUAC-DM3/SCH	341C-024-05-V	5 Nm	FR	-A131
	361C-024-10-V	10 Nm	FR	-A132
	328CS-024-05B-V/ST06	5 Nm	SL	-A133
	328CS-024-10B-V/ST06	10 Nm	SL	-A134
- 327VM-24-05-MB	Compact	5 Nm	-	-A160
- 327VM-24-10-MB	Compact	10 Nm	-	-A161
- 327VM-24-15-MB	Compact	15 Nm	-	-A162
- 327VM-24-05-DS4-MB	Compact	5 Nm	-	-A163
- 327VM-24-10-DS4-MB	Compact	10 Nm	-	-A164
- 327VM-24-15-DS4-MB	Compact	15 Nm	-	-A165
- 327VM-24-05-DS6-MB	Compact	5 Nm	-	-A166
- 327VM-24-10-DS6-MB	Compact	10 Nm	-	-A167
- 327VM-24-15-DS6-MB	Compact	15 Nm	-	-A168

Electric controller - alternative				
Controller	Actuator	DM	AN	AG
- Siemens :				
- GDB181.1E/3	Compact	5 Nm	-	-A076
- GLB181.1E/3	Compact	10 Nm	-	-A077
- GDB181.1E/KN	Compact	5 Nm	-	-A078
- GLB181.1E/KN	Compact	10 Nm	-	-A079
- Sauter :				
- ASV215BF132E	Compact	10 Nm	-	-A138
- ASV215BF152E	Compact	10 Nm	SL	-A139

Pneumatic controller - standard				
Controller	servo cylinder	DM	AN	AG
- Sauter :				
- RLP100 F003	AK31P1 F001	70 N	LA	-A106
	AK42P F003	200 N	LA	-A107

Pneumatic controller - alternative				
Controller	servo cylinder	DM	AN	AG
- Sauter :				
- RLP100 F914	AK31P1 F001	70 N	LA	-A108
	AK42P F003	200 N	LA	-A109

Accessories:

S1A/S2A, limit switch make Belimo, to fit all new compact controllers and actuators of make Belimo.

ZTH EU, PC-Tool and ZTH EU for Belimo LMV-D3-MP / AST20 for Siemens GLB 181.1 E/3 / WIN-VAV-2 for Gruner 327VM.

DM = Torque

AN = Actuator type

SL (High-speed damper drive)

SR (High-speed damper drive with return)

FR (Spring return)

LA (Linear drive)

- (standard)

AG = Attachment assembly

## Volumetric flow controller VRAQ

### Maintenance and service

#### Assembly and maintenance instructions

1. When the device is delivered, check whether the controllers are complete and have been delivered without damage. Complaints have to be communicated immediately and directly to the transporter and SCHAKO.
2. The volumetric flow controller must not be carried on the regulation components, measuring cross or the damper leaf, but only on the housing.
3. The controllers must be carefully stored on-site. They must be protected from dust, dirt and from direct weather effects.
4. The controllers must be assembled in a way to allow inspection.
5. Assembly must be carried out by expert personnel, observing recognised technical rules and regulations.
6. For explosion-proof rooms, explosion-protected control components must be used.
7. **For polluted air, the volumetric flow controllers must be used with an integrated controller with a static membrane pressure sensor. In this case, it is absolutely necessary to observe the mounting position. The volumetric flow controllers are not suitable for air containing sticky and greasy particles.**

#### Zero adjustment of the static pressure sensors VFP-...

The pressure probe is based on a static pressure meter. Great care must be taken to ensure correct transport and correct assembly. The volumetric flow controllers have been adjusted in-factory by the OEM manufacturer according to their mounting position. If the controllers are installed in another position the sensors can be adjusted as follows.

1. Sensor VFP-... must be installed.
2. Connect VFP-... to VRP and supply VRP with 24 V AC mains voltage.
3. Remove lid from VFP-... .
4. Move damper to the "OPEN" position.
5. Pull damper drive plug from the VRP.
6. Remove the pressure hoses from the connection spigots.  
**Attention!** Make a note of the (+) and (-) assignments.
7. The membrane position is considered balanced when both LEDs are dark (OFF). If the meter position is not balanced, one of the two LEDs will light up, and the position must be adjusted on the potentiometer in the VFP-...
8. Slowly turn the zero point adjustment of the potentiometer (non-painted potentiometer), until both LEDs are dark (OFF).
9. Assemble lid of VFP-....
10. Reconnect pressure hoses, (+) and (-) as before.
11. Reconnect the plug of the damper drive.

#### Cleaning of the dynamic differential pressure sensor

The differential pressure sensor integrated in the **NMV-D3-MP**, **LMV-D3-MP** and **VRU-D3-BAC** requires little maintenance. However, if, depending on the degree of pollution of the air, unexpected volumetric flow deviations occur, then the following procedure is recommended.

1. Pull off the pressure hoses from the sensor connection spigot of the NMV-D3-MP, LMV-D3-MP or of the VRU-D3-BAC .  
**Attention!** Make a note of the (+) and (-) assignments.
2. Using a suitable hand pump, blow air into the (-) spigot of the sensor (this will blow any dirt deposited inside the sensor out of the (+) spigot).
3. Remove any dirt that may have formed from the spigots and hose ends.
4. Reconnect pressure hoses, (+) and (-) as before.
5. Carry out a functional check of the controller.

### Legend

V	(m <sup>3</sup> /h) [l/s]	= Air volume
V <sub>min</sub>	(m <sup>3</sup> /h) [l/s]	= Minimum volumetric flow
V <sub>max</sub>	(m <sup>3</sup> /h) [l/s]	= Maximum volumetric flow
Δp <sub>t</sub>	(Pa)	= Pressure loss
L <sub>W</sub>	[dB/Okt]	= Sound power level / octave (L <sub>W</sub> = L <sub>W1</sub> + KF)
L <sub>W1</sub>	[dB/Okt]	= Sound power level / octave, relative to 1 m <sup>2</sup> of inflow area
L <sub>WA</sub>	[dB(A)]	= A-weighted sound power level (L <sub>WA</sub> = L <sub>WA1</sub> + KF)
L <sub>WA1</sub>	[dB(A)]	= A-weighted sound power level in duct, relative to 1 m <sup>2</sup> of inflow area
L <sub>W abst</sub>	[dB/Okt]	= Radiated noise / octave
A	(m <sup>2</sup> )	= Inflow area (W x H)
B	(mm)	= Width
H	(mm)	= Height
D <sub>e</sub>	[dB/Okt]	= Insertion loss
f <sub>m</sub>	(Hz)	= Octave band centre frequency
v	(m/s)	= Air velocity
v <sub>K</sub>	(m/s)	= Duct velocity
KF	(-)	= Correction factor
U <sub>5</sub>	(V) DC	= Measurement output (electric voltage)
EW	(%)	= Set value
EK	(m/s)	= Calibration curve
F	(m <sup>2</sup> )	= Area
KA	(-)	= Number of baffles
x		= available
--		= not available

## Volumetric flow controller VRAQ

### Order code VRAQ

01	02	03	04	05	06
Type	Model	Width	Height	Material	Attachment assembly
<b>Example</b>					
VRAQ	-HP	-0252	-0201	-DD	-A003

07	08	09	10	11
Mode	Volumetric flow $V_{\min}$	Volumetric flow $V_{\max}$	Acoustic cladding	Damper position
-0	-00100	-00300	-DS4	-NA

#### Sample

**VRAQ-HP-0252-0201-DD-A003-0-00100-00300-DS4-NA**

Volumetric flow controller type VRAQ, rectangular design | HP | Width 252 mm | Height 201 mm | Galvanised sheet steel with DD coating | With LMV-D3-MP SO | 0-10 V |  $V_{\min}$  = 100 m<sup>3</sup>/h |  $V_{\max}$  = 300 m<sup>3</sup>/h | With acoustic cladding 40 mm | No spring return actuator

### ORDER DETAILS

#### 01 - Type

VRAQ = Volumetric flow controller VRAQ, rectangular design

#### 02 - Model

HP = Type HP (not air-tight).  
H = 100-180 / W = 140-565  
H = 201-1003 / W = 201-1003

HU = Type HU (not air-tight).  
H = 100-180 / W = 140-565  
H = 201-1003 / W = 201-1003

JP = Type JP (sealing air-tight):  
H = 201-1003 / W = 201-1003  
H = 318 not available!

JU = Type JU (sealing air-tight):  
H = 201-1003 / W = 201-1003  
H = 318 not available!

For other sizes which are not available, see page 6 / 7 / 8 / 9 .

#### 03 - Width

0140 - 0160 - 0180 - 0201 - 0225 - 0252 - 0318 - 0357 - 0400  
- 0449 - 0503 - 0565 - 0634 - 0711 - 0797 - 0894 - 1003  
in mm, always with 4 digits.

#### 04 - Height

0100 - 0140 - 0160 - 0180 - 0201 - 0225 - 0252 - 0318 - 0357  
- 0400 - 0449 - 0503 - 0565 - 0634 - 0711 - 0797 - 0894 - 1003  
in mm, always with 4 digits.

#### 05 - Material

SV = Galvanised sheet steel (standard).  
DD = DD coating on the inside with galvanised sheet steel  
(only available for HP and HU).

#### 06 - Attachment assembly

- with electric controller – standard:

A003 = LMV-D3-MP, Compact (5 Nm)  
A004 = NMV-D3-MP, Compact (10 Nm)  
A005 = SMV-D3-MP, Compact (20 Nm)

- with electric controller – alternative:

A142 = VRU-D3-BAC, LM24A-VST (5 Nm)  
A143 = VRU-D3-BAC, NM24A-VST (10 Nm)  
A144 = VRU-D3-BAC, SM24A-VST (20 Nm)

other modules available upon request (see Controller selection table on page 43).

- with pneumatic controller – standard:

A106 = RLP100 F003, AK31P1 F001 (linear drive, 70 N).  
A107 = RLP100 F003, AK42P F003 (linear drive, 200 N).

- with pneumatic controller – alternative:

A108 = RLP100 F914, AK31P1 F001 (linear drive, 70 N).  
A109 = RLP100 F914 AK42P F003 (linear drive, 200 N).

#### 07 - Mode

0 = 0-10 V  
2 = 2-10 V (standard) (Pneumatic controllers can only be delivered in mode 2!)

#### 08 - Volumetric flow set value $V_{\min}/V_{\text{kon}}$

00000 = ex-works according to table.  
xxxxx = 5-digit value in m<sup>3</sup>/h.

#### 09 - Volumetric flow set value $V_{\max}$

00000 = ex-works according to table.  
xxxxx = 5-digit value in m<sup>3</sup>/h.

#### 10 - Acoustic cladding

DS0 = without acoustic cladding (standard).  
DS4 = with acoustic cladding 40 mm.

#### 11 - Damper position

NA = no spring return actuator (standard).  
NO = currentless OPEN - normally open.  
NC = currentless CLOSED - normally closed.

(only for drives with spring return)

With pneumatic drive correspondingly depressurised OPEN / depressurised CLOSED.

## Volumetric flow controller VRAQ

### Order code ZSQ

01	02	03	04	05	06
Type	Model	Width	Height	Material	Profiled connection frame
<b>Example</b>					
ZSQ	-VRAQ	-0711	-0565	-SV	-M3

All fields must be filled when ordering.

#### Sample

#### ZSQ-VRAQ-0711-0565-SV-M3

Mineral wool silencer, rectangular design, with baffles type MWK-OB | For volumetric flow controller type VRAQ | Width 711 mm | Height 565 mm | Made of galvanised sheet steel | With Metu profile M3

### ORDER DETAILS

#### 01 - Type

ZSQ = Mineral wool baffle silencer, rectangular design, with baffles type MWK-OB.

#### 02 - Model

VRAQ = Volumetric flow controller type VRAQ

VQEX = ATEX volumetric flow controller type VQEX

VAQS = Volumetric flow controller type VAQS

VMPQ = Mechanical volumetric flow controller type VMPQ

#### 03 - Width

Width	VRAQ	VQEX	VAQS	VMPQ
0140	X	--	--	--
0150	--	--	X	--
0160	X	--	--	--
0180	X	--	--	--
0200	--	--	X	X
0201	X	X	--	--
0225	X	X	--	--
0250	--	--	X	--
0252	X	X	--	--
0300	--	--	X	X
0318	X	X	--	--
0350	--	--	X	--
0357	X	X	--	--
0400	X	X	X	X
0449	X	X	--	--
0500	--	--	X	X
0503	X	X	--	--
0565	X	X	--	--
0600	--	--	X	X
0634	X	X	--	--
0700	--	--	X	--
0711	X	X	--	--
0797	X	X	--	--
0800	--	--	X	--
0894	X	X	--	--
0900	--	--	X	--
1000	--	--	X	--
1003	X	X	--	--

in mm, always with 4 digits

#### 04 - Height

Height	VRAQ	VQEX	VAQS	VMPQ
0100	X	--	X	X
0140	X	--	--	--
0150	--	--	--	X
0160	X	--	--	--
0180	X	--	--	--
0200	--	--	X	X
0201	X	X	--	--
0225	X	--	--	--
0250	--	--	--	X
0252	X	--	--	--
0300	--	--	X	X
0318	X	--	--	--
0357	X	X	--	--
0400	X	X	X	X
0449	X	--	--	--
0500	--	--	X	--
0503	X	--	--	--
0565	X	X	--	--
0634	X	--	--	--
0711	X	X	--	--
0797	X	--	--	--
0894	X	--	--	--
1003	X	X	--	--

in mm, always with 4 digits

#### 05 - Material

SV = galvanised sheet steel

#### 06 - Profiled connection frame

M2 = Metu profile M2 (for VAQS and VMPQ)

M3 = Metu profile M3 (for VRAQ and VQEX)

X = available

-- = not available

## Volumetric flow controller VRAQ

### Specification texts

Volumetric flow controller in rectangular design, for spiral duct connection to DIN EN 1505 / DIN 24190, for use in supply and return air systems for constant or variable volumetric flow, room or duct pressure regulation. With positive control  $V_{\min}$ ,  $V_{\max}$  or "CLOSED". Allowed pressure difference range: 50-1000 Pa, allowed ambient temperature 0...+50°C. Suitable for use with duct velocities of 1-12 m/s. It is possible to subsequently adjust the operating volumetric flows set ex works. Can be fitted position-independently. The output signal can be used for master/slave or parallel operation of several controllers or for actual value display 2-10 V DC (0-10 V DC), which corresponds to 0-100% of the set  $V_{\max}$  in DDC / ZLT systems (for more information, please refer to technical data sheet GUAC-SM3/SCH Universal **and 327VM-... Compact** from Gruner). Housing made of galvanised sheet steel. Opposed blades, made of galvanised sheet steel, not sealing airtight, with plastic bearing. Measuring cross made of extruded aluminium profile, measuring cross support made of plastic (PA6). Right-hand design. With electric controller, control voltage 24 V AC, 50/60 Hz, requirement: measuring air 0 °C to 50 °C/5-95% relative humidity, non-condensing, wired and adjusted in-factory. TÜV inspected according to VDI 6022 Sheet 1.

Product: SCHAKO **type VRAQ-HP**

- Opposed blades, made of galvanised sheet steel, not sealing airtight, with sintered bearing.

Product: SCHAKO **type VRAQ-HU**

- Opposed blades made of extruded aluminium profile, sealing air-tight to DIN EN 1751, up to class 4, with plastic bearing.

Product: SCHAKO **type VRAQ-JP**

- Opposed blades made of extruded aluminium profile, sealing air-tight to DIN EN 1751, up to class 4, with sintered bearing.

Product: SCHAKO **type VRAQ-JU**

- Housing leakage according to DIN EN 1751, class C, at a duct pressure of up to 1000 Pa.

- Leakage with closed blades according to DIN EN 1751, up to class 4 at a duct pressure of up to 1000 Pa (VRAQ-JP / VRAQ-JU... only).

Higher requirements upon request.

- Housing (at an extra charge) made of:
  - galvanised sheet steel with DD coating (-DD) (not possible for VRAQ-JP / VRAQ-JU)

- with spring return actuator (at an extra charge)
  - currentless "CLOSED" (-NC)
  - currentless "OPEN" (-NO)

With pneumatic drive correspondingly depressurised OPEN / depressurised CLOSED.

- with pneumatic controller, feed pressure  $1.2 \pm 0.1$  bar, for use with duct velocity 3-12 m/s:
  - depressurised "CLOSED" or
  - Depressurised "OPEN"

**For controller selection (attachment assembly), see page 43.**

**Accessories** (at an extra charge):

- Acoustic cladding (-DS4) made of 40 mm (pressed to 35 mm) sound-absorbing material, with sheet metal casing made of galvanised sheet steel, non-flammable to DIN 4102-17, including M8 cage nuts.
- Mineral wool silencer (-ZSQ) with M3 Metu profile on both sides, housing (L=1500) consisting of galvanised sheet steel with integrated MWK-OB silencing baffles (L=1000). The MWK-OB silencing baffles with RAL quality seal consist of abrasion-resistant mineral fibre boards covered with fibre glass filament (biosoluble, non-flammable to DIN 4102 A2) in a frame of galvanised sheet steel. Baffles measured to ISO/DIS 7235 and to DIN 45646.