



Additional operating instructions according to ATEX 94/9/EC Volumetric flow controller VM-PRO-Ex



Ferdinand Schad KG
Steigstraße 25-27
D-78600 Kolbingen
Telefon 0 74 63 - 980 - 0
Telefax 0 74 63 - 980 - 200
info@schako.de
www.schako.de

Zusatzbetriebsanleitung nach ATEX 94/9/EG für Volumenstromregler VM-PRO-Ex

Inhalt	
General conditions	3
General description and instructions	3
Personnel qualification and training	3
Safety-conscious work	3
Designated use	3
Delivery and storage	3
Mounting information	3
Maintenance	3
Hazard caused by non-observance of the safety instructions	3
Description	4
Correction factors regarding the air volumes	4
Field of application	4
Installation	5
Construction	6
model	6
Accessories	6
Models and dimensions	6
Dimensions	6
Dimensions of accessories	7
Information regarding assembly and commissioning	9
Information regarding maintenance and inspection	9
Use and electrical connection of actuators in areas subject to explosion hazards	9
Certificate of conformity	10

Zusatzbetriebsanleitung nach ATEX 94/9/EG für Volumenstromregler VM-PRO-Ex

Zertifikatsnummer EPS 14 ATEX 2 706X

General conditions

General description and instructions



These additional operating instructions must be observed prior to mounting and commissioning the device.

These additional operating instructions contain basic information regarding its use in areas subject to explosion hazards to be observed during assembly, operation and maintenance.

Prior to mounting and commissioning and during maintenance work, the present additional operating instructions must be read by the installer and the responsible skilled personnel/system operator!

Personnel qualification and training

The personnel for assembly, inspection and maintenance must have the relevant qualification for this work.

The area of responsibility, competence and monitoring of the personnel must be exactly regulated by the system operator. If the personnel does not have the required knowledge, it must be trained and instructed. Moreover, the system operator must ensure that the contents of the additional operating instructions are understood completely by the personnel.

Safety-conscious work

The safety instructions given in these additional operating instructions, the existing national and international regulations on explosion protection, accident prevention and the system operator's internal work, operating and safety regulations must be observed.

Designated use

The volumetric flow controller has the following ATEX marking:

II 2 G IIC T6
II 2 D T80°C
 II 3 G IIC T6
II 3 D T80°C

The devices have been designed for use in ventilation systems in areas subject to explosion hazards according to ATEX of Category II, Zones 1, 2 and Category III, Zones 21, 22.

These devices are not suitable for use in unclassified Ex zones.

The operating safety of the delivered devices is only guaranteed when used in accordance with their designated use.

Delivery and storage

Upon receipt, the devices must be checked for completeness and transport damage. If delivered incompletely or damaged, the forwarding company and the SCHAKO KG have to be informed immediately.

The device must not be exposed directly to weather, solar radiation and moisture.

Mounting information

Mounting, electrical connection work and commissioning must be carried out by skilled personnel only and in accordance with the recognised technical rules and the safety and accident prevention regulations.

Maintenance

Only a device subjected to proper maintenance and kept in perfect condition can guarantee safe and reliable operation.

When defective parts are replaced with spare parts, only SCHAKO original spare parts may be used. The SCHAKO KG cannot be held liable for any damage caused by using spare parts that are not original and will not give any warranty.

Hazard caused by non-observance of the safety instructions

Non-observance of the safety instructions can result both in putting persons and the environment and operating units at risk. Likewise, non-observance of the safety instructions will result in the loss of any claims for damages.

Zusatzbetriebsanleitung nach ATEX 94/9/EG Volumenstromregler VM-PRO-Ex

Zertifikatsnummer EPS 14 ATEX 2 706X

Description

The constant volumetric flow controller VM-PRO-Ex **works independently without auxiliary power**. The central, ball-bearing flap is moved by the air flow. The control unit with control cam, spring and damper is attached to the outside of the galvanised sheet steel housing. The specified **volumetric flow is set ex factory**. **An adjustment of the volumetric flow at a later stage is possible** (setting cam on housing). The control unit is protected with a cover. The controller can be assembled in any assembly position.

Operating temperature: 10-50° C.

Differential pressure range: 50 - 500 Pa

Housing leakage according to DIN EN 1751, class C

Correction factors regarding the air volumes

In controller position 1 and 2, Δp must be >100 Pa.

For Δp 1000 Pa deviations of up to 20% of the set value can occur.

Maximum deviation compared to the set value

Air velocity	2-4 m/s	± 10%
Air velocity	5-6 m/s	± 8%
Air velocity	7-8 m/s	± 6%
Air velocity	9-10 m/s	± 5%
Scale inaccuracy		± 4%

Maximum deviation compared to the set value

NW 80 starting from a static minimum pressure difference Δp 100 Pa

Air velocity	3-4 m/s	±20%
Air velocity	5-6 m/s	±16%
Air velocity	7-8 m/s	±10%
Air velocity	9-10 m/s	±8%
Scale inaccuracy		± 4%

The mechanical volumetric flow controller VM-PRO-R-E-Ex / VM-PRO-Q-E-Ex with actuator is suitable for adjusting the supply or return air volume to varying room occupancy. Should this become necessary, it can be done without removing the false ceiling.

The volume control damper type VM-PRO-Ex is delivered with the setting "1". The controller must be connected on-site to the power supply and then adjusted on-site to the desired controller position. The control unit including regulating curve, spring, damper and actuator is

attached to the outside of the galvanised sheet steel housing. The required volumetric flow is set in-factory.

Thanks to the actuator, the volumetric flow controller can be adjusted without problems to any required volumetric flow within the controller range.

To avoid unnecessary controller errors, the information given on p. 5 should be observed. The setting values for actuators with constant control can be obtained from the controller settings. In OPEN / CLOSED actuators, the control setting is effected through a mechanical limit.

For maintenance, service, retrofitting, etc., inspection openings in sufficient number and size must be provided on site.

Field of application

- for supply and return air systems
- for regulation of the constant volumetric flow with the option for electrical setpoint adjustment (VM-PRO-E-Ex)

Attention:

The VM-PRO-Ex is an adjusted controller working by the mechanism of action principle. Tampering with the controller, whether manually or mechanically, are prohibited. When a high volumetric flow setting has been selected, the damper leaf must never be closed manually. Otherwise, the control mechanism will be changed, resulting in a loss of control accuracy. The field of application must always be complied with. Use of VM-PRO-Ex beyond its allowed field of application results in mechanical overload and, thus, in loss of control accuracy.

We would like to point out that only suitable cleaning agents may be used to clean the stainless steel design!

Volumetric flow ranges for VM-PRO-R-Ex

NW (mm)	V _{ZU} (m³/h)		V _{ZU} [l/s]	
	min.	max.	min.	max.
80	50	170	14	47
100	70	260	19	72
125	120	420	33	117
160	180	700	50	194
200	250	1200	70	333
250	300	1500	83	417
315	450	2200	125	611
400	700	4200	195	1167

Volumetric flow ranges for VM-PRO-Q-Ex

WxH (mm)	V _{ZU} (m³/h)		V _{ZU} [l/s]	
	min.	max.	min.	max.
200 x 100	200	800	56	222
300 x 100	325	1075	90	299
300 x 150	250	1500	69	417
300 x 200	225	1800	63	500
400 x 200	500	2050	139	569
400 x 250	850	3200	236	889
400 x 300	700	3600	194	1000
400 x 400	900	4400	250	1222
500 x 200	650	3100	181	861
500 x 250	950	4200	264	1167
500 x 300	1200	4800	333	1333
500 x 400	1300	6200	361	1722
600 x 200	450	4100	125	1139
600 x 250	1200	4600	333	1278
600 x 300	1700	5800	472	1611
600 x 400	1900	8200	528	2278

Zusatzbetriebsanleitung nach ATEX 94/9/EG für Volumenstromregler VM-PRO-Ex

Zertifikatsnummer EPS 14 ATEX 2 706X

Installation

Installation information

To avoid unnecessary controller errors, the min. distances according to the following table / drawings must be observed. For combinations of several connection pieces or pieces with fire dampers or silencers, the larger minimum distances must be observed.

The volumetric flow controllers VM-PRO-R-Ex and VM-PRO-Q-Ex can be assembled with horizontal or vertical damper axis.

Distance to	VM-PRO-R-Ex	VM-PRO-Q-Ex
Connection piece with bend	1 x D	1 x diagonal
Other connection pieces: (e.g. T-junction, branching piece, reduction piece, etc.)	2 x D	2 x diagonal
Fire damper:	2 x D	2 x diagonal
Silencers:	2 x D	2 x diagonal

Installation information for VM-PRO-R-Ex (round)

Distance to a connection spigot with bend

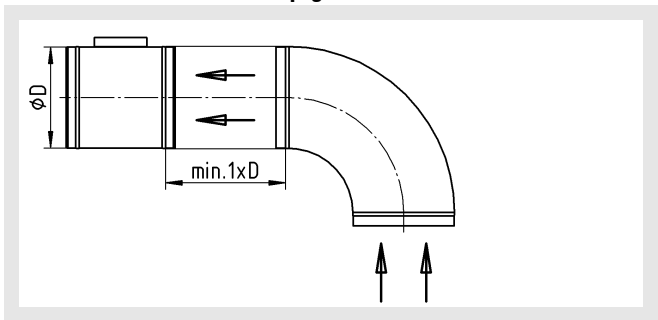

Installation information for VM-PRO-Q-Ex (square)

Distance to a connection spigot with bend

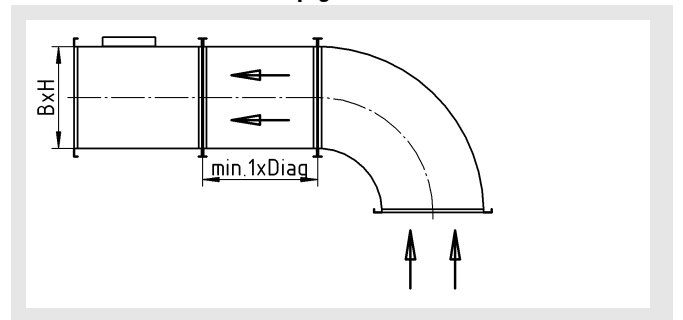

Distance to other connection pieces

(e.g. branching piece, reducing piece, T-junction, etc.)

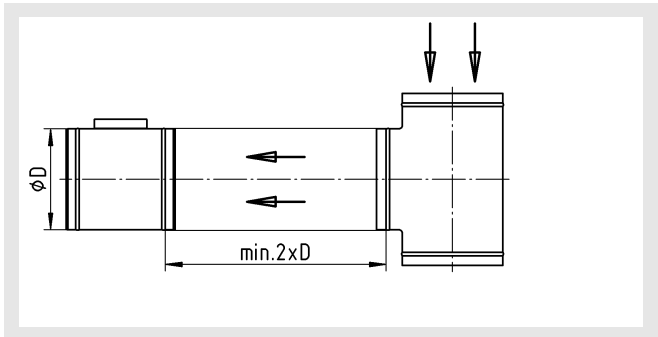

Distance to other connection pieces

(e.g. branching piece, reducing piece, T-junction, etc.)

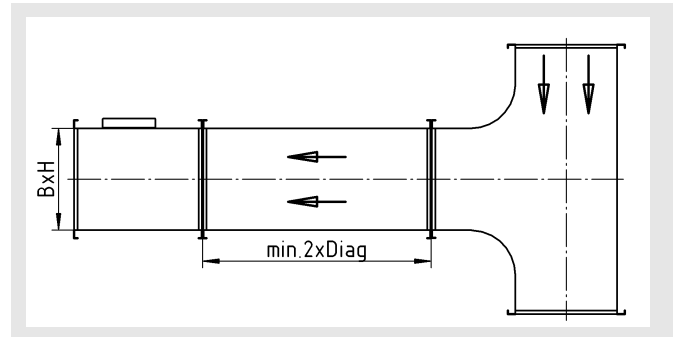

Distance to a fire damper

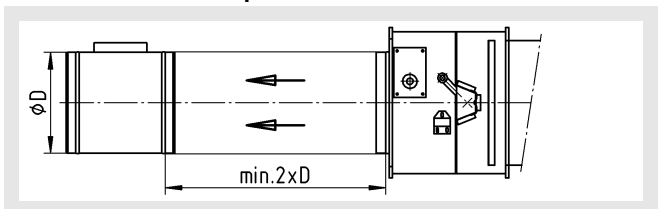

Distance to a fire damper

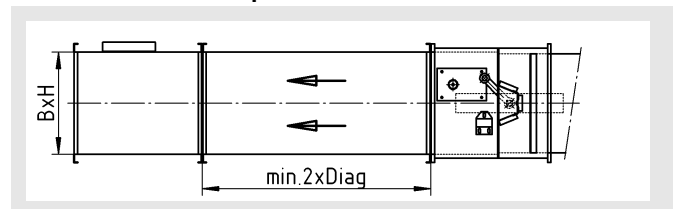

Distance to a silencer

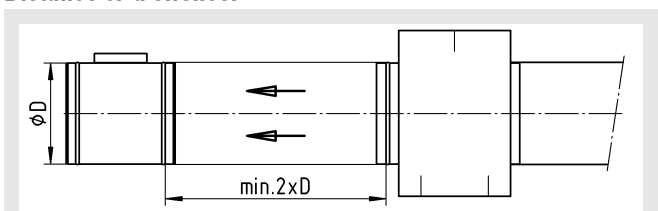

Distance to a silencer

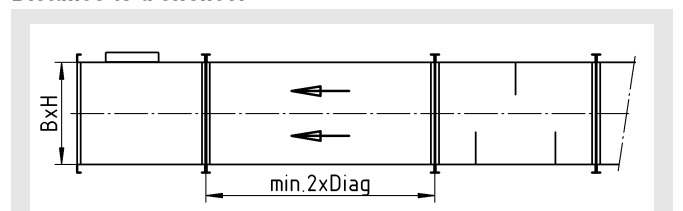

D = diameter

Diag = diagonal

Zusatzbetriebsanleitung nach ATEX 94/9/EG für Volumenstromregler VM-PRO-Ex

Zertifikatsnummer EPS 14 ATEX 2 706X

VM-PRO-Q-Ex

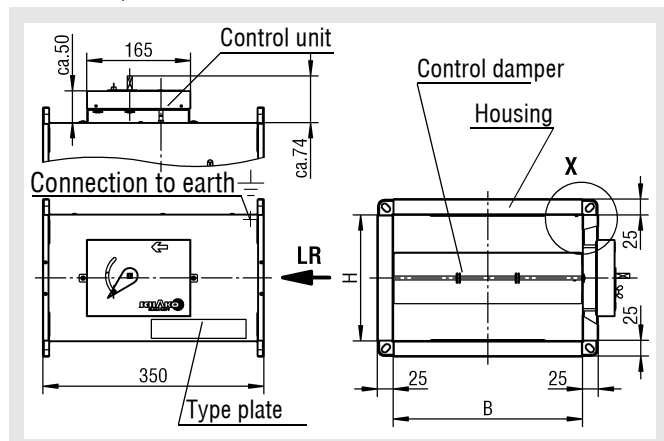

The VM-PRO-Q-Ex is delivered in right-hand design only. If the layout of the control unit is required on the left side, then VM-PRO-Q-Ex must be rotated by 180°.

Available sizes VM-PRO-Q-Ex

Height H	Width B				
	200	300	400	500	600
100	X	X	-	-	-
150	-	X	-	-	-
200	-	X	X	X	X
250	-	-	X	X	X
300	-	-	X	X	X
400	-	-	X ^{1.)}	X ^{1.)}	X ^{1.)}

X = available

- = not available

LR = Air flow direction

1.) = including two control units

Corner angle

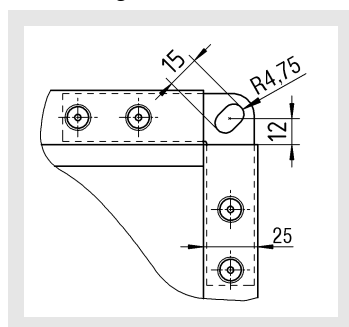

As standard, the volumetric flow controller VM-PRO-Q-Ex is delivered with corner angle. The special form of the corner holes allows them to be connected to the connection systems available on the market (e.g. Metu system M 2/M 3)

Dimensions of accessories

for VM-PRO-R-Ex

with acoustic cladding (-DS, insulation 20mm)

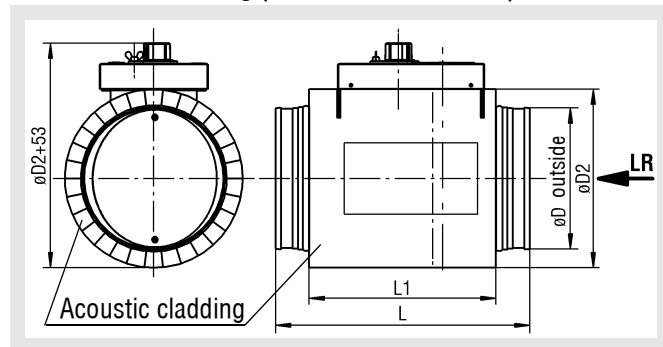

with electric actuator (-E) - ATEX

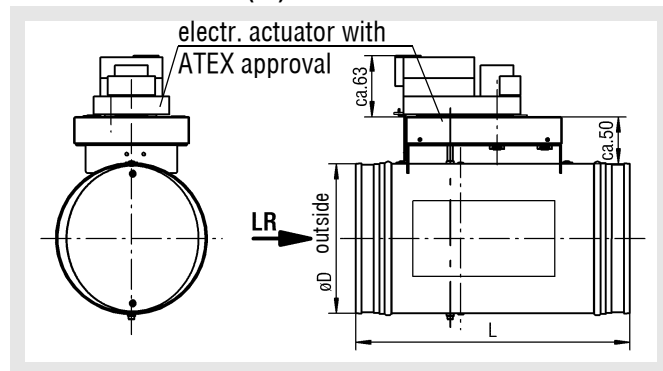

Available sizes (-DS / -E)

NW	øD	øD1	øD2	L	L1
80	78	84	120	290	180
100	98	104	140	290	180
125	123	129	165	290	180
160	158	164	200	290	180
200	198	204	240	290	205
250	248	254	290	390	230
315	313	319	355	390	260
400	398	404	440	490	360

LR = Air flow direction

for VM-PRO-Q-Ex

with acoustic cladding (-DS, insulation 20mm)

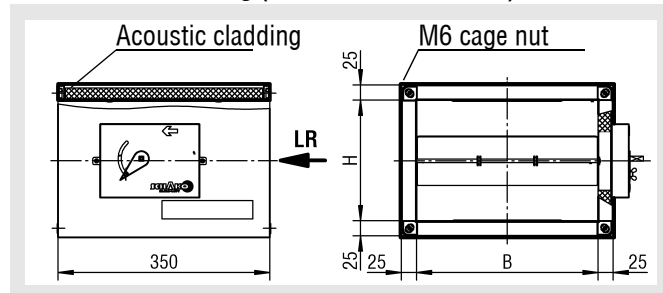

Zusatzbetriebsanleitung nach ATEX 94/9/EG Volumenstromregler VM-PRO-Ex

Zertifikatsnummer EPS 14 ATEX 2 706X

with electric actuator (-E) - ATEX

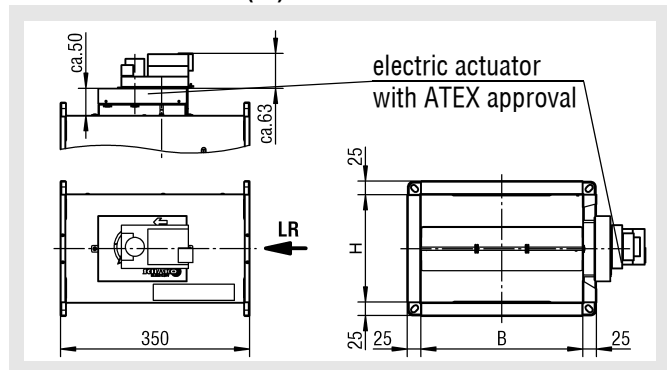

Flat flange (-FF), both sides (VM-PRO-R-Ex only) according to DIN 24 154/5

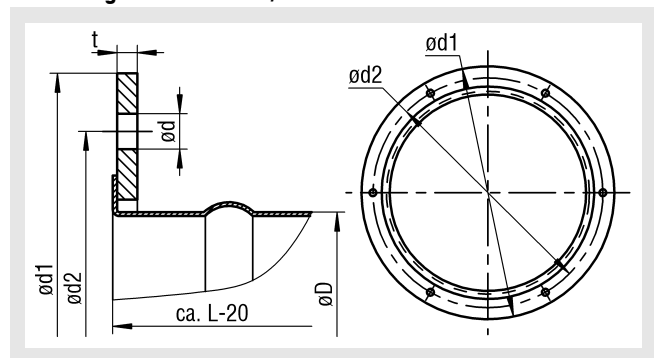

Available sizes (-DS/ -E)

Height H	Width B				
	200	300	400	500	600
100	X	X	-	-	-
150	-	X	-	-	-
200	-	X	X	X	X
250	-	-	X	X	X
300	-	-	X	X	X
400	-	-	X ^{1.)}	X ^{1.)}	X ^{1.)}

X = available

- = not available

LR = Air flow direction

1.) = including two control units

Available sizes flat flange (-FF)

NW	øD	L	ød1	ød2	ød	LOA	t
80	78	290	132	108	7	4	3
100	98	290	154	129	7	4	3
125	123	290	177	155	7	4	3
160	158	290	222	194	7	6	4
200	198	290	263	235	7	6	4
250	248	390	313	286	7	6	4
315	313	390	388	356	9,5	8	5
400	398	490	474	438	9,5	12	5

* Number of holes

Metu flange (-MF) / Counter flange (-GF) / Tension ring (-SR) on both sides (VM-PRO-R-Ex only)

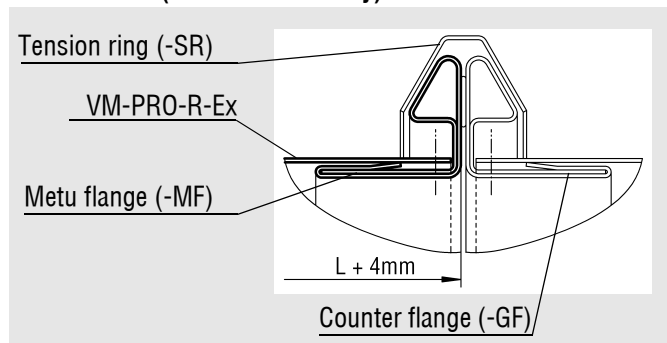

Rubber lip seal (-GD) (VM-PRO-R-Ex only)

Detail X

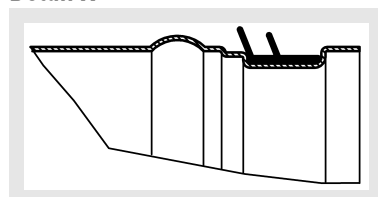

Zusatzbetriebsanleitung nach ATEX 94/9/EG für Volumenstromregler VM-PRO-Ex

Zertifikatsnummer EPS 14 ATEX 2 706X

Information regarding assembly and commissioning

Prior to being installed in the ventilation system, the volumetric flow controller must be checked for damage. Damaged volumetric flow controllers must not be installed.

The device may only be used in accordance with its designated use in air ventilation systems for supply air and return air.

The volumetric flow controller must be mounted only using approved fastening material.

No additional parts may be fastened on the volumetric flow controller.

The device must be connected to the ventilation duct network on both sides in electrically conducting manner.

In order to avoid the risk of static charges, the volumetric flow controller must be connected to the on-site equipotential bonding on the grounding connection provided for this purpose.

Make sure that the ventilation systems are not subjected to any anomalous operating conditions, such as vibrations, pressure surges or high proportions of solids in the medium.

For electrical connection diagrams, refer to the respective Schako additional information.

Electrical wiring and commissioning work must be performed by skilled personnel only.

Information regarding maintenance and inspection

Proper maintenance increases operational safety and the service life of the device. This is why the devices should be subjected to regular inspection.

If inspection dates are prescribed by law, they must be complied with.

The operating personnel must be informed, prior to starting maintenance and inspection work.

The personal safety measures must be looked up in the safety data sheet. Hazard caused by contact or inhaling hazardous substances must be excluded by taking appropriate safety measures.

Prior to maintenance or inspection, all system components up- and downstream of the device must be switched off and secured against being switched on again.

The following inspection criteria must be observed:

- Visual inspection of the device
- Check the fastening of the device
- Check the electrical connections
- Check the grounding connection for tight fit and good contact
- Functional check
- For additional inspections, please refer to the technical documentation or additional maintenance instructions



Attention:

Danger due to electrostatic charges.
Clean with moist cloth only.

Use and electrical connection of actuators in areas subject to explosion hazards

Only ATEX-approved electrical equipment according to ATEX Directive 94/9/EC for Zones 1, 2, 21, 22, such as actuators, terminal boxes and thermocouples as specified by SCHAKO may be used for devices from SCHAKO KG.

For the technical data and connection diagrams, please refer to the technical documentation.

The connection lines must be installed firmly and in such a way that they are sufficiently protected from mechanical and thermal damage.

Devices with explosion-protected drives and terminal boxes have to be attached over the external potential connecting terminal to the potential equalisation provided by the customer with at least 4 mm² cooper solid-core.

The electrical connection lines of the actuators must be connected in a terminal box according ATEX Directive 94/9/EC for Zones 1, 2, 21, 22 if the electrical connection is made in the area subject to explosion hazards.

The dimensioning of the conductor cross-sections must be observed.

The actuators are maintenance-free with respect to their function, but the relevant maintenance regulations according to ATEX directives or factory regulations must be observed.

For the technical data and connection diagrams, refer to the technical Schischeck documentation.

Zusatzbetriebsanleitung nach ATEX 94/9/EG Volumenstromregler VM-PRO-Ex Zertifikatsnummer EPS 14 ATEX 2 706X Certificate of conformity



(1) Konformitätsbescheinigung

- (2) Geräte und Schutzsysteme zur bestimmungsgemäßen Verwendung in explosionsgefährdeten Bereichen – Richtlinie 94/9/EG
- (3) Konformitätsbescheinigungsnummer
EPS 14 ATEX 2 706 X Revision: 0
- (4) Gerät: Volumenstromregler Typ: VM-PRO-R-Ex, VM-PRO-Q-Ex
- (5) Hersteller: Schako KG
- (6) Anschrift: Steigstraße 25 – 27, D-78600 Kolbingen
- (7) Die Bauart dieses Gerätes sowie die verschiedenen zulässigen Ausführungen sind in der Anlage zu dieser Konformitätsbescheinigung festgelegt.
- (8) Die Bureau Veritas Consumer Products Services Germany GmbH bescheinigt als Benannte Stelle Nr. 2004 nach Artikel 9 der Richtlinie des Rates der Europäischen Gemeinschaft vom 23. März 1994 (94/9/EG) aufgrund einer freiwilligen Prüfung die Erfüllung der grundlegenden Sicherheits- und Gesundheitsanforderungen für die Konzeption und den Bau von Geräten und Schutzsystemen zur bestimmungsgemäßen Verwendung in explosionsgefährdeten Bereichen gemäß Anhang II der Richtlinie. Die Ergebnisse der Prüfung sind in dem vertraulichen Prüfbericht 14TH0275 festgelegt.
- (9) Die grundlegenden Sicherheits- und Gesundheitsanforderungen werden erfüllt durch Übereinstimmung mit:

EN 13463-1:2009

- (10) Falls das Zeichen „X“ hinter der Bescheinigungsnummer steht, wird auf besondere Bedingungen für die sichere Anwendung des Gerätes in der Anlage zu dieser Bescheinigung hingewiesen.
- (11) Diese EG-Konformitätsbescheinigung bezieht sich nur auf Konzeption und Bau des festgelegten Gerätes gemäß Richtlinie 94/9/EG. Weitere Anforderungen dieser Richtlinie gelten für die Herstellung und das in Verkehrbringen dieses Gerätes.
- (12) Die Kennzeichnung des Gerätes muss die folgenden Angaben enthalten:



Ex II 2 G IIC T6
II 2 D T80°C

Türkheim, 03.09.2014

Seite 1 / 2

Bescheinigungen ohne Unterschrift haben keine Gültigkeit. Diese Bescheinigung darf nur unverändert weiterverbreitet werden. Auszüge oder Änderungen bedürfen der Genehmigung von Bureau Veritas Consumer Products Services Germany GmbH.

Zusatzbetriebsanleitung nach ATEX 94/9/EG für Volumenstromregler VM-PRO-Ex Zertifikatsnummer EPS 14 ATEX 2 706X



- (13) **Anlage**
- (14) **Konformitätsbescheinigung EPS 14 ATEX 2 706 X**
- (15) Beschreibung des Gerätes:

Der Volumenstromregler wird zur druckunabhängigen Regelung von Volumenströmen in Lüftungs- und Klimaanlage eingesetzt. Der Volumenstromregler arbeitet selbstständig ohne Hilfsenergie. Die zentrisch, kugelgelagerte Klappe wird von der Luftgeschwindigkeit bewegt. Eine Regeleinheit mit Regelkurve, Feder und Dämpfer ist außen am verzinkten Stahlblechgehäuse angebaut. Der vorgegebene Volumenstrom wird werkseitig eingestellt. Ein nachträgliches Verstellen des Volumenstroms ist möglich. Die Regeleinheit ist durch eine Abdeckhaube geschützt.

- (16) Prüfbericht: 14TH0275

- (17) Besondere Bedingungen:

Es muss sichergestellt werden, dass alle metallischen Teile sowie die leitfähigen Kunststoffe ordnungsgemäß und dauerhaft mit dem Erdpotential verbunden sind.

Die an- und eingebauten elektrischen Geräte müssen in geeigneter Weise explosionsgeschützt ausgeführt sein. Die Zusammenführung von elektrischen und nichtelektrischen Geräten muss erneut sicherheitstechnisch betrachtet werden.

Zur Vermeidung von Gleitstielbüschelentladungen muss bei den Gehäusen mit RAL Lack sichergestellt werden, dass die Luft im Lüftungssystem keine starke Belastung an nichtleitfähigen Partikeln aufweist.

- (18) Grundlegende Sicherheits- und Gesundheitsanforderungen:

Durch Normen abgedeckt.

Zertifizierungsstelle Explosionsschutz

Türkheim, 03.09.2014



D. Zitzmann

Seite 2 / 2

Bescheinigungen ohne Unterschrift haben keine Gültigkeit. Diese Bescheinigung darf nur unverändert weiterverbreitet werden. Auszüge oder Änderungen bedürfen der Genehmigung von Bureau Veritas Consumer Products Services Germany GmbH.

EPS 14 ATEX 2 706 X Rev. 0