



Smoke detection system

Model RMS



SCHAKO KG
Steigstraße 25-27
D-78600 Kolbingen
Telephone +49 (0) 74 63 - 980 - 0
Fax +49 (0) 74 63 - 980 - 200
info@schako.de
schako.com

Smoke detection system RMS

Contents

Description	3
Application	3
Advantages	3
RMS	4
Function (special scattered light method)	4
Construction	5
Accessories	5
Fastening	5
Dimensions	5
Technical data	8
Smoke detector (-RMS)	8
Relay module 4.00 (-RM)	8
Relay module 5.00 (-RM)	10
Maintenance / Inspection	12
Order details	13
Specification texts	13

Smoke detection system RMS

Description

Application

The SCHAKO smoke detection system consists of the smoke detector RMS and the relay module RM V4.00 or RM 5.00 and is used in places where, at the earliest possible stage of a fire (upon occurrence of cold smoke of $< 72\text{ °C}$), triggering and switching operations are to be controlled automatically. It can be fitted to ventilation ducts. If detected, the propagation of smoke in the air duct system is prevented for the most part by closing the fire or smoke dampers. The alarm message is transmitted via a potential-free contact and interrupts the electric circuit to the electric trigger devices (magnetic clamps, spring return actuators) or to pneumatic drives. **The connected fire dampers and smoke dampers are closed. Only trigger devices working by the "zero-current closed/ depressurised closed" working principle must be connected to the RMS system.** The smoke detectors and the connected trigger and switch devices are supplied jointly with power from a relay module 230 V AC and a secondary 24 V DC within a protection area. The smoke detectors remain in alarm condition after being triggered, even after the normal ambient conditions have been restored. The smoke detectors will not return to their monitoring status until the relay module is reset. The measurement takes place outside the smoke detector housing, thus **not requiring any detection chamber**. Approved for ventilation ducts of air velocities between 1 m/s and 20 m/s.

Advantages

- As no detection chamber is required for measurements, no medium flows through the smoke detector and deposits can only be formed on the safety glass, allowing easy cleaning.
- Fitted flush with the duct.
- Automatic tampering detection.
- Self-function test of the transmitter and receiver sensors. A defect is displayed.
- When a power, processor or system failure occurs, a fault message is displayed simultaneously with an alarm message.
- Includes system monitoring (watchdog).
- Bus connection possible via potential-free contacts.
- Connection to the communicative Signalling and Switching Bus System + Easy Bus possible.
- Maintenance required once a year

Industrial property rights owned by SCHAKO:

- Patent: DE 199 51 403 A1
- Registered utility model: 20023533.8
- Patent: EP 122 4641
- VdS approval for RMS: G209206

External monitoring is done by the VdS Schadensverhütung GmbH Köln (VdS Damage Prevention Branch, Cologne)

When integrating SCHAKO components into customer facilities, any compatibility problems are not our responsibility and must be eliminated by the customer.

Installation and mounting

Installation in duct

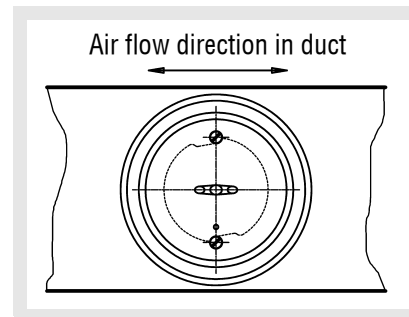

Fig. front side

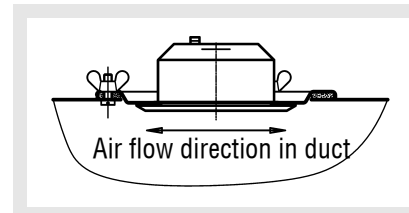

Fig. lateral side

The smoke detector must be installed such that it is permanently located in the air flow (**not in the inspection opening of the fire damper**).

Smoke detection system RMS

Installation arrangement and mounting

The smoke detector must be fitted free of vibration if possible. When charged with steam, disinfectant, dust, soot (exhaust gases) or dew, an alarm or fault message is triggered.

Assembly in ducts

1. Establish smoke detector position (not in the inspection opening of the fire damper), and mark the middle.
2. Cut out a hole of 120 mm in diameter.
3. Drill mounting holes (only when installed on site in the ventilation duct).
4. Insert the delivered insulating sleeves into the mounting holes.
5. Fit smoke detector with mounting frame and seal, fasten with thumb nuts or Parker screws.
6. During installation, observe air flow direction.
7. Carry out electrical wiring according to wiring diagram.
8. Before putting the RMS into operation, the duct system must be cleaned completely. Care must be taken that the glass front is sprayed again with an antistatic spray after wiping it clean with a damp cloth.

When fitting the RMS smoke detector, care must be taken that in a 100 mm radius around the detector, nothing can reflect the emitted sensor signals.

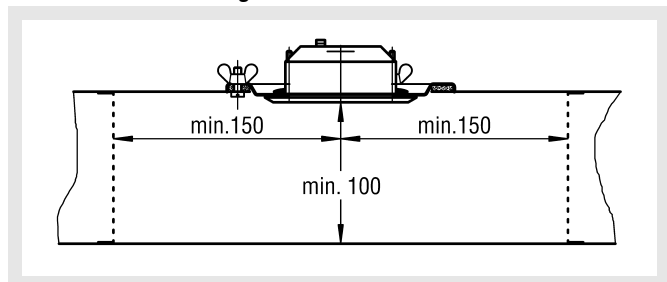

Connection

Connecting the power supply. When the output voltage is active, the orange operating indicator lamp will flash.

Note

Before the first startup of the smoke detector, the ducts must be cleaned so as to avoid any accidental alarm message.

The relay modules are equipped with a controller with power limiter and thermal protection. When a short-circuit occurs, the controller switches off the output voltage. An interruption in the mains supply voltage or the "+" output line will restore the function of the smoke detector.

After fitting the smoke detector RMS on site ready to operate, an acceptance test immediately prior to putting the fire damper or smoke detector into operation must establish that the installation conforms to the regulations and that the smoke detector functions properly, especially that all components interact correctly. The acceptance test must be documented by the building owner of the ventilation system. The documents must be filed by the building owner/operator of the ventilation system.

For maintenance, service, retrofitting, etc., inspection openings in sufficient number and size must be provided on site.

RMS

Function (scattered light principle)

Two sensors in the smoke detector send out a light beam and measure if the air on the front of the safety glass is contaminated with smoke or other particles. Before triggering an alarm, various measurement cycles must be carried out, during which the contamination in the air must be measured. If the contamination is not permanently present, then the internal measurement cycle counter is reset. The response sensitivity of the smoke detector is set inalterably ex works. The alarm output is a potential-free change-over contact. The smoke detector can be reset to the ready-to-operate mode by remote control.

A power failure at the smoke detector can be displayed at the central unit. In this case, the electric circuit for the release device is interrupted on the connected fire dampers, and the dampers are closed. Tampering with the smoke detector, for example by taping the sensors, is detected and, if required, reported to the central unit via a potential-free contact (error output). Deposits on the safety glass of the smoke detector are detected and evaluated. When a certain degree of soiling is exceeded, it is reported as a fault message to the switchboard via a potential-free contact. In this way, the smoke detection system monitors itself.

Smoke detection system RMS

Construction

Smoke detector base

- Polycarbonate

Connecting cable

- 2.0 m with 9-pin Sub D plug. The 9-pin Sub D terminal for the electric supply and trigger lines is located inside the base.

Individual display

- LED on duct exterior

Mounting frame

- Sheet steel, with seal

Accessories

Assembly part type EBT

- for installation flush with the duct, made of galvanised sheet steel.
- Housing leakage according to DIN EN 1751, class B, at a duct pressure of up to 1000 Pa.

Assembly part (-REBT / -REBTF)

- for installation in round ducts, made of galvanised sheet steel.
- Housing leakage according to DIN EN 1751, class B, at a duct pressure of up to 1000 Pa.
- Model
 - without flange (-REBT), with rubber lip seal made of special rubber.
 - with flange (-REBTF), on both sides, to EN 12220.

Fastening

Screw connection

- with thumb nuts or Parker screws

Dimensions

Smoke detection system RMS

for installation in rectangular ducts **without** assembly part!

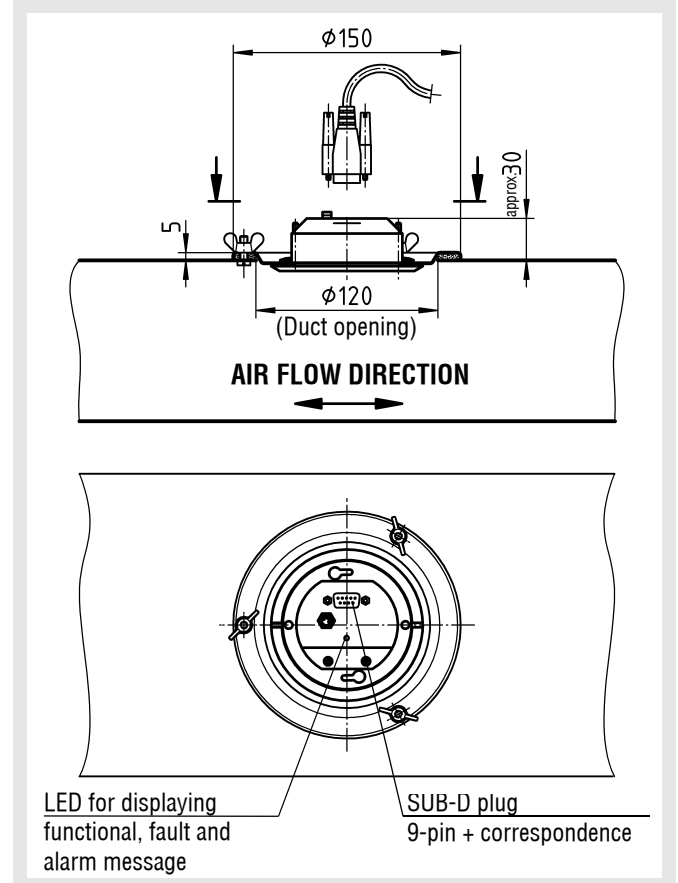

Smoke detection system RMS

Accessories

with assembly part (-EBT), for fire damper installation
 - Installation in duct topside

- Installation in duct side wall

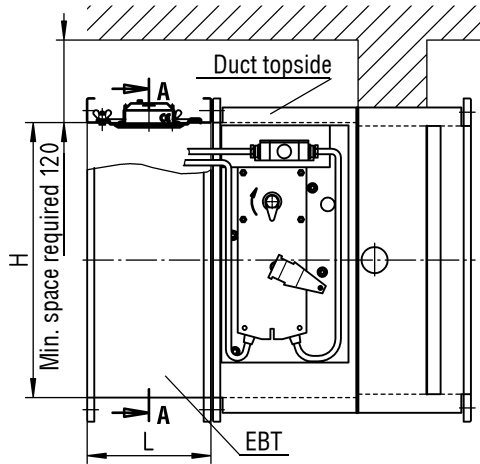

Section A-A / centre assembly
 for $B \leq 700$

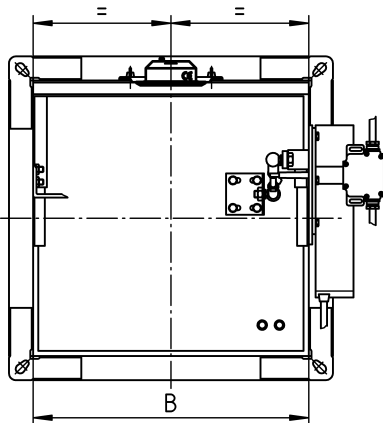

Section A-A / off-centre assembly
 for $B > 700$

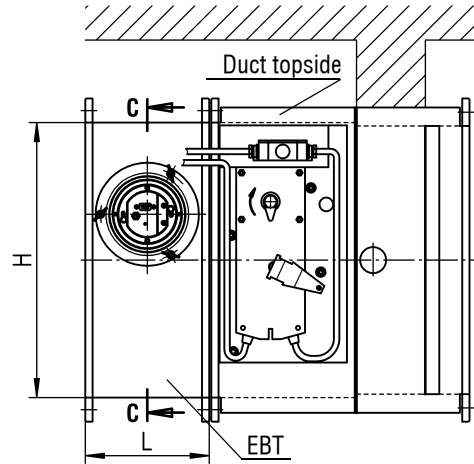
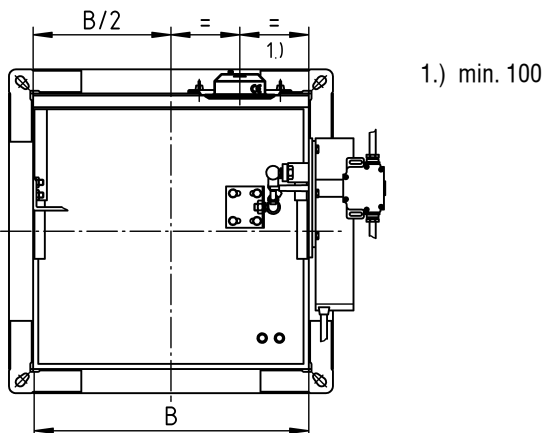

Section C-C

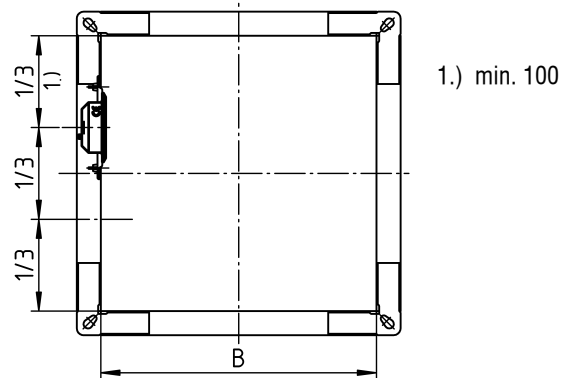

The dimension L depends on the height H (mm).

H (mm)	L (mm)
200 - 750	180
800	210

The smoke detector must always be assembled in the assembly part type EBT on the operator side (trigger device, drive) (not in the inspection opening of the fire damper).

Smoke detection system RMS

Technical data

Smoke detector (-RMS)

Operating voltage:	24 V DC (+15% -20%)
Residual ripple:	< 20%
Max. current consumption:	25 mA
Switching contacts:	- 1 alarm output (potential-free change-over contact) - 1 fault output (potential-free change-over contact)
Max. switching voltage:	100 V DC / 125 V AC
Max. switching current:	1.0 A
Max. switching power:	30 W / 62.5 V A
Operating temperature and ambient temperature:	0 °C to +60 °C
Protection type according to DIN 40050:	IP 40
Weight:	0.2 kg
Storage temperature:	max. 75°C
Relative humidity:	10 - 90%

Individual display - LED display:

- flashing orange = Function
- permanently red = Alarm
- permanently orange = Fault / Soiling

Connection assignment of the 9-pin SUB-D plug:

Assignment	Relay		Meaning
	de-energised	operating	
1	-	-	GND
2			Relay contact work contact fault
3			Relay contact centre contact fault
4			Relay contact rest contact fault
5	-	-	Test switch to GND
6			Relay contact rest contact alarm
7			Relay contact centre contact Alarm
8			Relay contact work contact alarm
9	-	-	+24 V

The relays drop off when an alarm / a fault or a power cut occurs.

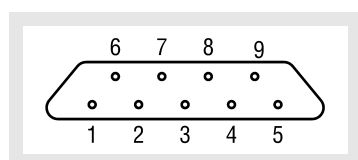

Relay module 4.00 (-RM)

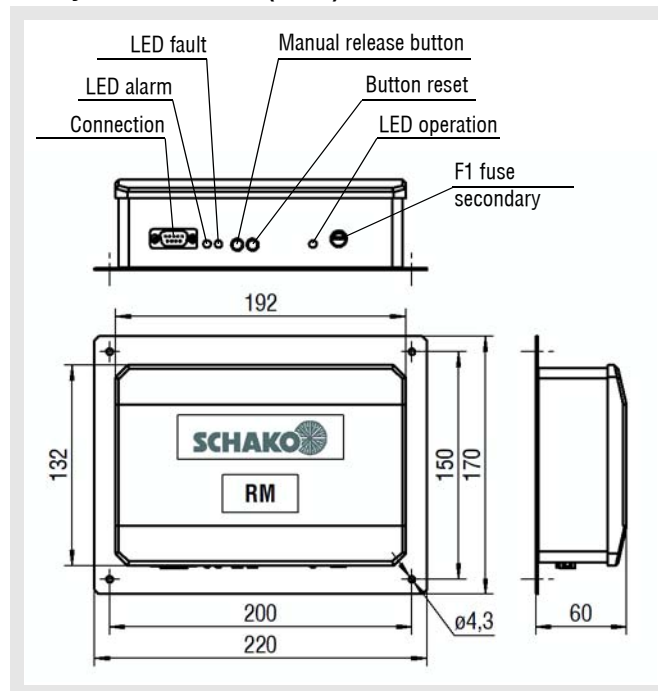

The RMS is connected to the power supply by means of a relay module 4.00 (9-pin SUB-D socket). Moreover, the reset button RST and the test switch have already been mounted on the relay module. This makes it easier to check the fire damper closing function via the test switch and/or to reset the alarm message via the reset button RST. Additional terminal strips for spring return actuator and / or fan disconnection or other switching operations will shorten the installation time and prevent wrong wiring.

A 24 V spring return actuator can be activated via the 3-pin AMP plug (standard Belimo BLF, BF, BFG).

RM 4.00

Operating voltage:	230 V AC, 50 Hz
Dimensioning:	23 VA
Ambient temperature:	0-40°C
Relative humidity:	0-90%
Degree of protection:	IP 30

Smoke detection system RMS

Circuit diagram of relay module 4.00

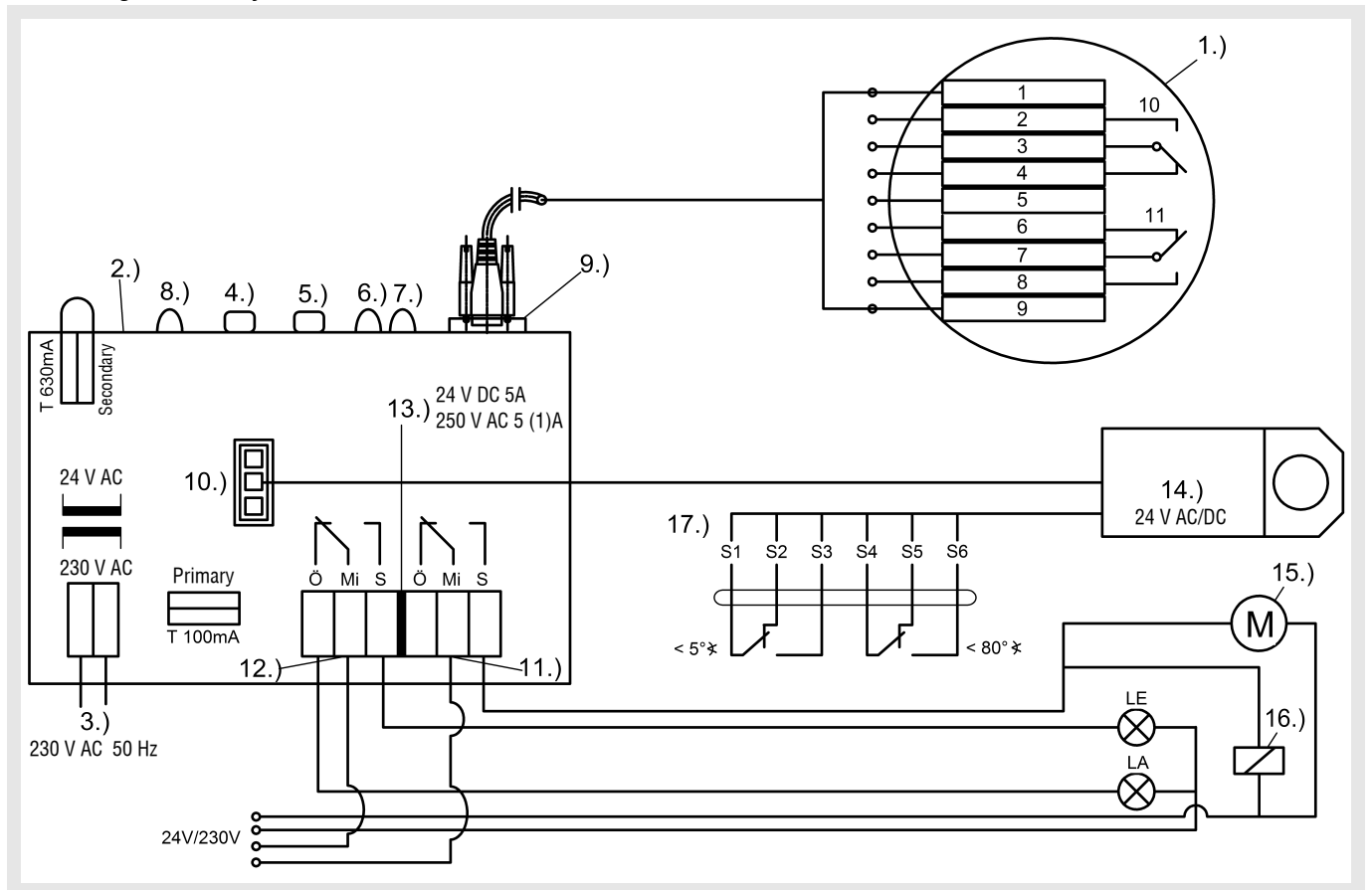

- 1.) Smoke detectors
- 2.) Relay module
- 3.) Mains connection
- 4.) Reset button
- 5.) Manual release
- 6.) LED fault
- 7.) LED alarm
- 8.) LED operation
- 9.) Connection RMS
- 10.) AMP plug for 24V AC/DC actuators (max. 10 VA)
- 11.) Selector switch 1, e.g., actuator
- 12.) Selector switch 2, e.g., light
- 13.) Contact load of the selector switches
- 14.) Spring return actuator 24 V AC/DC for fire damper. SCHAKO product or external product (for the technical data, please refer to the motor data sheet)
- 15.) Spring return actuator 24 V AC/DC / 230 V AC SCHAKO product or external product (optional) (for the technical data, please refer to the motor data sheet)
- 16.) Magnetic clamp / pneumatic valve (optional)
- 17.) Limit switch spring return actuator (connection is fitted in a T-piece socket on-site)

Contact assignment RMS:

- | | |
|----|----------------------------|
| 1 | GND |
| 2 | Work contact |
| 3 | Centre contact |
| 4 | Rest contact |
| 5 | Test switch / RST |
| 6 | Rest contact |
| 7 | Centre contact |
| 8 | Work contact |
| 9 | +24 V |
| 10 | FAULT |
| 11 | Alarm |
| Ö | = NC contact |
| Mi | = Centre contact |
| S | = NO contact |
| LA | = Ventilation OFF (option) |
| LE | = Ventilation ON (option) |

The de-energised state is shown. For relay module, also the alarm or fault condition.

Smoke detection system RMS

Relay module 5.00 (-RM)

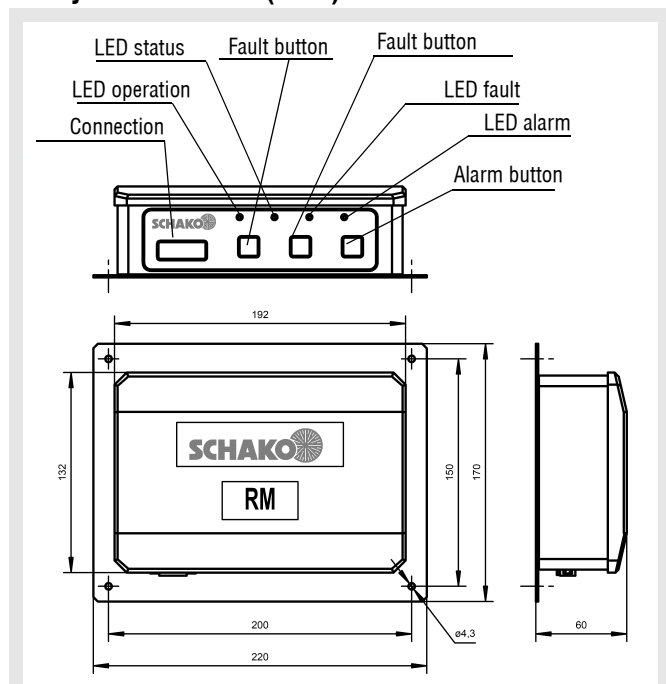

The relay module 5.00 – together with the smoke detector RMS – controls and monitors fire dampers and smoke dampers. In addition, alarms and faults can be forwarded to the building management system (BMS), fire alarm centre or to the ventilation unit to shut down the ventilation system. The status of the end positions can be evaluated and also forwarded. In case of smoke detection or fault, the power supply to the connected damper and the ventilation unit is interrupted. The relay module has a reset button and a test switch (manual trigger button). The relay module must close the fire damper or other shut-off device against fire and smoke in the following cases:

- smoke detection by the smoke detector
- fault (e.g. cable break, missing smoke detector, short circuit)
- very heavy contamination, when smoke detection is no longer possible
- power supply failure
- return of the power supply after having been triggered previously (smoke detection and/or fault)
- pressing the button for the manual triggering

After a power supply failure with subsequent return of the power supply without previous triggering (smoke detection and/or fault), the relay module with smoke detector automatically returns to operational readiness.

The input voltage is either 230 V AC or 24 V AC. The RM 5.00 supplies the smoke detector RMS with the operating voltage of 24 V DC. The spring return motor of the fire damper or smoke damper, which can be connected as an option, is supplied with an operating voltage of 230 V AC, 24 V AC or 24 V DC (3-pin AMP plug). Motors with 230 V AC can only be operated if the relay module is connected to a 230 V AC power supply. With 24 V AC motors, the relay module must be connected to a 24 V AC power supply. In addition, the jumper for operating a

24 V AC motor may only be set on configuration interface 19.) position A. Accordingly, for the operation of a 24 V DC motor, the jumper may only be set on configuration interface 19.) position B. Terminal strips for spring return actuator and / or fan disconnection or other switching operations will shorten the installation time and prevent wrong wiring.

The signal for switching off the ventilation system is provided via the potential-free contacts 26.) for alarm and 27.) for fault. These contacts must be connected in series to switch off the ventilation system in case of smoke detection or fault.

RM V 5.00

Power supply:	230 V AC 50 Hz (202-253V) 24 V AC (23-26V)
Ambient temperature:	0-40°C
Relative humidity:	0-90%
Degree of protection:	IP 30
Dimensioning	24 V DC (23-26 V) 0.35 A 24 V AC (23-26 V) 0.5 A 230 V AC 50 Hz (202-253 V) 0.5 A

Detail jumper setting

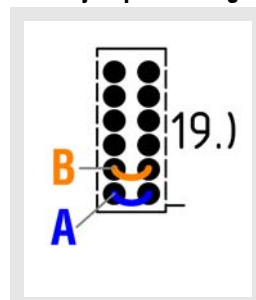

24 V DC motor	Set jumper at B
24 V AC motor	Set jumper at A
230 V AC motor	Set jumpers at A and B

Smoke detection system RMS

Circuit diagram of relay module 5.00

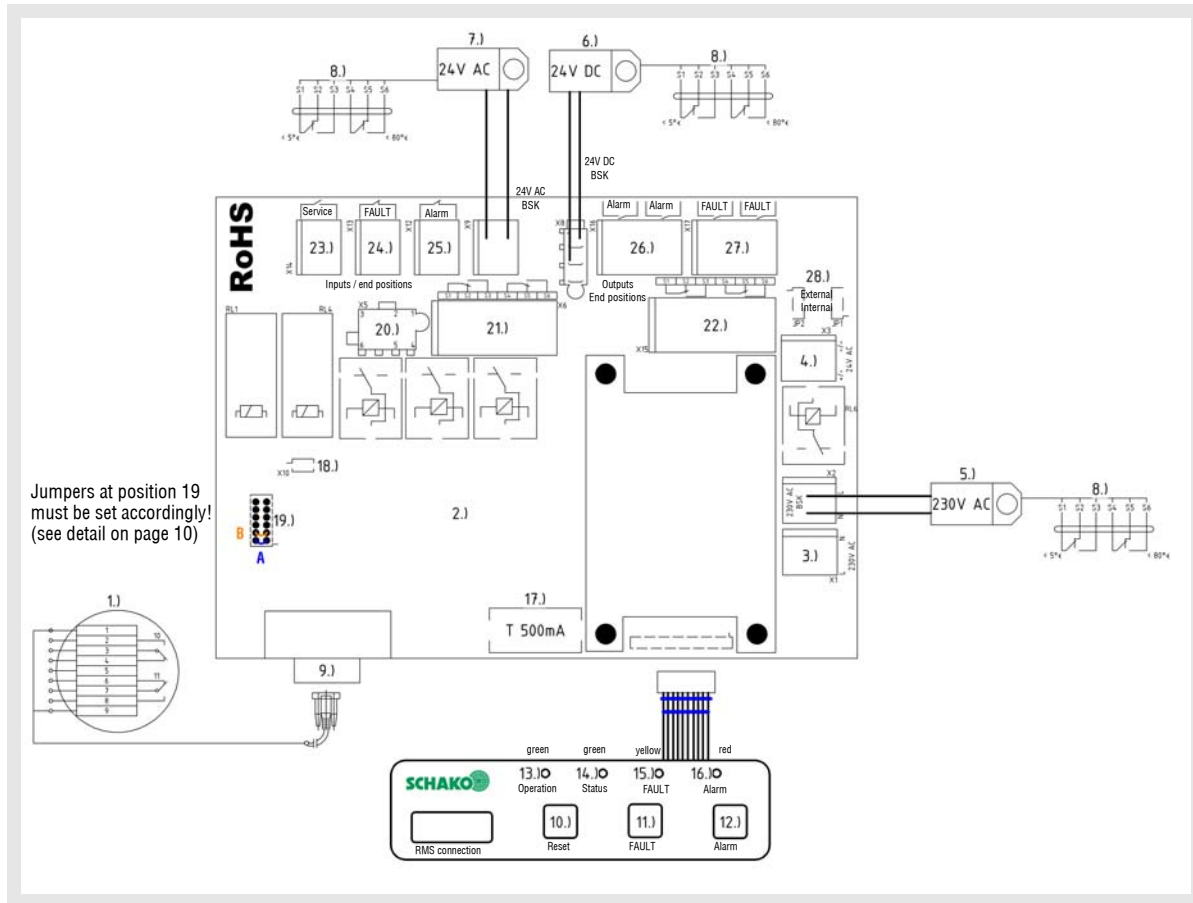

- | | |
|--|---|
| 1.) Smoke detectors | 23.) Service input (NO contact) |
| 2.) Relay module | 24.) Remote fault input (NC contact) |
| 3.) Power supply 230 V AC | 25.) Remote alarm input (NC contact) |
| 4.) Power supply 24 V AC | 26.) Output for looping through an alarm (open when the alarm is active) |
| 5.) Spring return actuator 230 V AC | 27.) Output for looping through a fault (open when the fault is active) |
| 6.) Spring return actuator 24 V DC | 28.) Jumper for selecting the supply voltage 24 V AC for spring return actuator |
| 7.) Spring return actuator 24 V AC | |
| 8.) Limit switch spring return actuator | |
| 9.) SUB-D connection of smoke detector | |
| 10.) Reset key | |
| 11.) Remote fault button | |
| 12.) Remote alarm button | |
| 13.) Operation LED | |
| 14.) Status LED | |
| 15.) Fault LED | |
| 16.) Alarm LED | |
| 17.) Microfuse | |
| 18.) X10 With closed contacts, the remote inputs 24.) and 25.) are blocked | |
| 19.) Configuration interface | |
| 20.) Input for end positions 8.) | |
| 21.) Input for end positions 8.) | |
| 22.) Output for looping through the end positions | |

Contact assignment RMS:

- 1.) GND
- 2.) Work contact
- 3.) Centre contact
- 4.) Rest contact
- 5.) Test switch / RST
- 6.) Rest contact
- 7.) Centre contact
- 8.) Work contact
- 9.) +24 V
- 10.) FAULT
- 11.) Alarm

The de-energised state is shown. For relay module, also the alarm or fault condition.

Smoke detection system RMS

Maintenance / Inspection

Maintenance of the smoke detection device for fire and smoke dampers must be carried out once a year or after a fault message, due to contamination.

Note

Installation and wiring must be carried out by authorised electricians only. The agreed regulations of the technician, safety and accident prevention regulations as well as the VDE guidelines, regulations of the local EVU's and the wiring instructions and connection plans of the manufacturer, must be adhered to when installing, wiring and commissioning. When wiring the junction boxes, make sure to earth the shielding. The smoke detector must be used according to this brochure description.

Maintenance instructions

The SCHAKO smoke detector type RMS permanently monitors itself and sends a fault message to the central unit if there is a mechanical or electrical defect or if it is too contaminated. When a power failure of the smoke detector occurs, a fault message is also sent to the central unit. This permanent self-monitoring allows a yearly maintenance interval.

Maintenance includes the following actions:

1. The type of use and installation situation must be checked for the first time during commissioning and then after modification.
2. The electrical connections must be checked for correct connection and perfect condition.
3. Checking whether the diode on the fitted smoke detector or relay module flashes orange, thus signalling ready operating state.
4. Electrical functionality control
The power supply of the smoke detector must be disconnected by removing the 9-pin Sub-D plug or by pressing the reset button on the relay module. This causes the smoke detector to send an alarm to the connected locking device, which will close automatically. The diode on the smoke detector or relay module is no longer lit. As soon as the power supply has been restored and the alarm has been acknowledged by pressing the reset button, the smoke detector must return to the ready operating state, and the diode on the smoke detector and / or relay module must flash orange.
5. Fault control
On the smoke detector RMS, the transmitter and receiver sensors must be covered. The diode on the smoke detector lights up permanently in orange. The fault contact reports a fault. After that, the cover must be removed again. The smoke detector must again return to the ready operating state, and the fault message is reset at the central unit.

6. Functionality control using test aerosols
When the smoke detector is fitted to ducts, a test aerosol must be applied to the smoke detector through an inspection opening.. This must be done by applying the test aerosol to the smoke detector increasingly in pulsed form for about 10 sec. When the alarm threshold values is exceeded, an alarm message will be triggered, and the connected locking devices must close automatically. The diodes on the smoke detector and on the relay module must light up in red. After the test aerosol components in the surrounding air of the smoke detector have decomposed to such an extent that the value drops again below the alarm threshold value, the alarm message is still displayed on the smoke detector and on the relay module. This is why the smoke detector must be activated again by pressing the reset button on the relay module. As soon as the diode on the smoke detector type RMS flashes in orange again and the red LED on the relay module goes out, the smoke detector is ready to operate again.
7. Elimination of defects
If defects have been detected during maintenance, they must be eliminated immediately. Defective components may only be replaced with original parts delivered by SCHAKO. Repair of the smoke detector and of the relay module must be carried out only by the appliance manufacturer. If any of the connected shut-off devices are not closing, even when the smoke detector and the relay module operate faultlessly, then the shut-off devices themselves must be checked.
8. If the maintenance and inspection instructions of this technical documentation are used for the annual check of the functioning of the SCHAKO smoke detection system (RMS), the smoke detector can remain in use until an inadmissible deviation is detected.

Inspection instructions

The SCHAKO smoke detector type RMS permanently monitors itself and sends a fault message to the central unit if there is a mechanical or electrical defect or if it is too contaminated. When a power failure of the smoke detector occurs, a fault message is also sent to the central unit.

Smoke detection system RMS

Order details

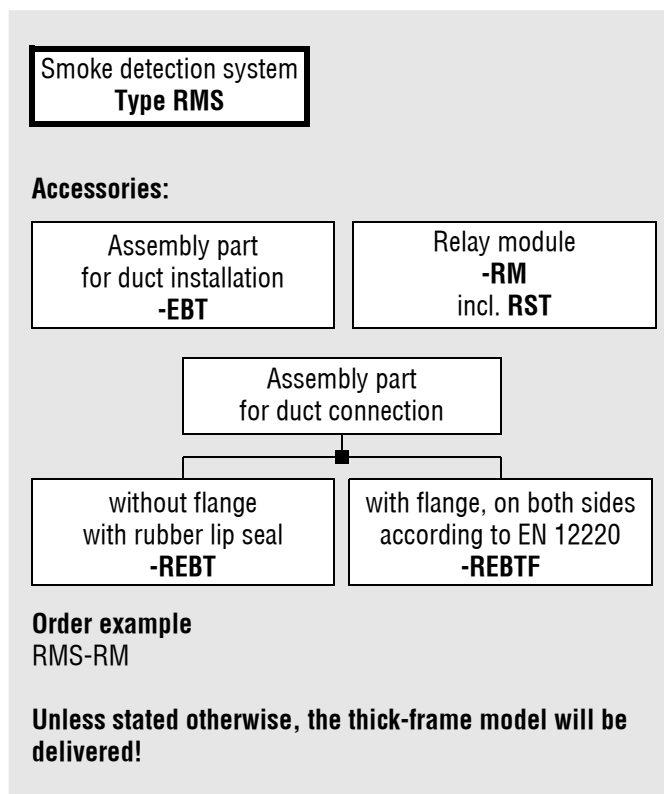

Specification texts

Smoke detection system **type RMS**, with annual maintenance, for installation flush with the duct or fire damper installation with assembly part type EBT (extra charge), with maintenance cover. Consisting of a housing, base, cover plate, similar to RAL 9010 (white), a mounting frame made of sheet steel with seal and with connecting cable 2.0 m long with Sub-D 9-pin connection. For use on fire and smoke dampers, with electric or pneumatic release devices working by the zero-current closed / depressurised closed functional principle, and with magnetic clamp and lifting magnet.

Two sensors self-monitoring permanently for correct functioning measure the air contamination due to smoke with a special scattered light procedure outside the housing, without using a detection chamber. They measure the degree of contamination at two points on the surface of the safety glass. Alarm and fault messages each take place via a potential free change-over contact. Manual triggering of the smoke detector possible via a reset button (at an extra charge).

Fastening with screw mounting (SM) (with thumb nuts or Parker screws).

Includes relay module (-RM) for supplying power and for alarm transmission incl. test switch and reset button

- with transformer for connection to 230 V AC 50 Hz or connection 24 V AC.

Product: SCHAKO **type RMS**

Accessories:

- Assembly part (-EBT) for simple duct installation in front of the fire damper. Consisting of galvanised sheet steel with connection flanges. Housing leakage according to DIN EN 1751, class B, at a duct pressure of up to 1000 Pa
- Assembly part (-REBT / -REBTF) for simple installation in round ducts in front of the fire damper. Consisting of galvanised sheet steel. Housing leakage according to DIN EN 1751, class B, at a duct pressure of up to 1000 Pa.
 - without flange (-REBT), with rubber lip seal made of special rubber.
 - with flange (-REBTF), on both sides, to EN 12220.