



# Displacement diffuser PUSH



SCHAKO KG  
Steigstraße 25-27  
D-78600 Kolbingen  
Telephone +49 (0) 74 63 - 980 - 0  
Fax +49 (0) 74 63 - 980 - 200  
[info@schako.de](mailto:info@schako.de)  
[schako.com](http://schako.com)

# Displacement Diffuser Model PUSH

## Contents

<b>Description</b> .....	<b>3</b>
Construction .....	4
Model .....	4
Accessories .....	4
Fastening .....	4
Quick selection (horizontal throw) .....	5
Operating range of volumetric flow .....	5
<b>Models and dimensions</b> .....	<b>5</b>
Air throw pattern .....	5
Dimensions .....	7
Installation options .....	10
<b>Technical data</b> .....	<b>11</b>
Pressure loss and noise level .....	11
Maximum end velocity of jet .....	14
Jet path .....	16
Vertical throw (in heating mode) .....	18
Induction ratio .....	20
Connection diagrams of electric actuators .....	21
Technical data of electric actuators .....	21
<b>Legend</b> .....	<b>21</b>
<b>Order code PUSH</b> .....	<b>22</b>
<b>Specification texts</b> .....	<b>24</b>

## Displacement Diffuser Model PUSH

### Description

Industrial plants with high levels of harmful emissions are usually ventilated using displacement ventilation, displacing harmful emissions from the occupied area towards the return air openings. The air is usually delivered via large capacity displacement diffusers located at floor level. This type of diffuser, however, wastes a lot of space in the occupied area and restricts the freedom of movement.

The displacement diffuser type PUSH has been developed to **prevent this waste of space**. This diffuser is **installed at a height of 3 - 4 m**, i.e., 1 - 2 m above the occupied area and can **disperse air volumes between 600 and 13000 m<sup>3</sup>/h**, allowing **temperature differences of -10 K during cooling and +25 K during heating**.

Via a chain, the **air throw pattern can be adjusted individually** by hand. However, a **centrally controlled motorised adjustment of the air throw pattern is also possible**.

The following air throw patterns are possible:

- horizontal throw (cooling mode):  
PUSH-1A/-1B/-02/-03/-04/-5B/-06
- diagonally downward throw (isothermal)  
PUSH-1A/-1B/-02/-04/-06
- vertical throw (heating mode):  
PUSH-02/-03/-04/-5B/-06

In the "horizontal throw" air throw pattern (cooling mode), the air is discharged diagonally upwards in horizontal direction. After a jet path of 2 - 3 m, the air jet slowly descends into the occupied zone at velocities of  $\leq 0.15$  m/s and displaces the room air towards the return air openings. In the "diagonally downward throw" air throw pattern (isothermal), the air displaces the room air in the proximity of the diffuser towards the return air openings. To effectively bring the warm air downward into the occupied area, in the "vertical throw" air throw pattern (heating mode), the air is discharged in vertical direction. Owing to the stable air throw pattern, a large penetration depth is reached. This allows the room to be heated quickly and economically. In designs in which the floor is closed, the sizes that can be used go only up to 315 mm for the heating mode. With larger sizes, the impulse is not sufficient for achieving large penetration depths.

The displacement diffusers allows the air throw pattern to be adjusted easily and precisely according to individual customer requirements. Intermediate positions allow the jet path in horizontal direction or the penetration depth in vertical direction to be changed. This is done by means of:

- PUSH-1A/-02/-03/-04: a locking mechanism (-AA) on the diffuser casing or the locking plate (-AW) on walls / columns.
- PUSH-1B: a Magura lever mounted on the impact ring axis (standard)
- PUSH-5B: with thermocouple
- PUSH-06: with adjustment rod

The direction of the baffle plate or base plate can be adjusted on site by means of screws to suit the on-site construction.

The diffuser can either be suspended freely (-F) or fixed to a wall / column (-W). For wall and column mounting, the air throw angle can be lowered from 360° to 270°. This is possible at a later stage by means of the accessory "1/4 cover" (-AD1/-AD2).

The standard length of the chain/cable for adjustment in the case of PUSH-1A/-02/-03/-04 is 3 m from the bottom edge of the diffuser. If a longer chain/cable is required, this must be indicated in the order (at an extra charge).

For air volume regulation, an adjustable damper (-DV1) can be fitted to the diffuser which can also be adjusted using a side-mounted lever when mounted.

A rubber gasket (GD1) and / or a honeycomb air flow straightener (-WG1/-DV2) can also be fitted to the connection side of the diffuser or the damper type DV1 at an extra charge. The honeycomb air flow straightener allows direct connection to junctions and bends.

### Adjustment by means of a thermal cylinder

The thermocouple adjusts the baffle plate and thus the air throw direction automatically as a function of the supply air temperature. This ensures optimum air distribution in the cooling and heating modes.

Please make sure that the thermocouple does not make contact with supply air of more than 40°C. This may deform the piston rod and thus result in damage and accidents!

The thermocouple for the model PUSH-5 B is suitable for supply air temperatures of approx. 15°C to max. 40°C.

For maintenance, service, retrofitting, etc., inspection openings in sufficient number and size must be provided on site.

## Displacement Diffuser Model PUSH

### Construction

Locking mechanism (-AA, für PUSH-1A/-02/-03/-04)

- Galvanised sheet steel (-SV, standard) at the diffuser casing
- Stainless steel 1.4301 (-V2) at the diffuser casing

Diffuser casing

- Galvanised sheet steel, 360° perforated (-SV-...-360, standard)
- Galvanised sheet steel, 270° perforated (-SV-...-270)
- Stainless steel 1.4301 (-V2)

Base plate and baffle plate

- Galvanised sheet steel (-SV, standard)
- Stainless steel 1.4301 (-V2)

Chain (for PUSH-1A/-02/-03/-04)

- Galvanised steel (-SV, standard)
- Stainless steel 1.4301 (-V2)

Damper leaf seal (for PUSH-02/-03/-04/-5B/-06)

- made of PUR, silicone-free
- for tight sealing of the base plate

Thermocouple

- for PUSH-5 B suitable for supply air temperatures of approx. 15°C to max. 40°C.

Adjustment rod

- for PUSH-06

### Model

- PUSH-1A - upper baffle plate adjustable by chain, closed base.
- PUSH-1B - upper baffle plate with Magura lever (mounted directly to impact ring axis) adjustable, closed base.
- PUSH-02 - upper baffle plate and base plate individually adjustable by chain.
- PUSH-03 - upper baffle plate and base plate jointly adjustable by chain.
- PUSH-04 - upper baffle plate adjustable by chain and base plate by electric actuator.
- PUSH-5B - Base plate adjustable by thermocouple and upper baffle plate fixed.
- PUSH-06 - upper baffle plate and base plate individually adjustable by adjustment rod.
- PUSH-...-360-... - Diffuser casing with a 360° perforation
- PUSH-...-270-... - Diffuser casing with a 270° perforation
- PUSH-...-F-... - Suspended installation
- PUSH-...-W-... - Wall/column installation

### Accessories

1/4 cover

- Galvanised sheet steel (-AD1)
- Stainless steel 1.4301 (-AD2)

Locking plate (-AW, for PUSH-1A/-02/-03/-04)

- Galvanised sheet steel (-SV, standard)
- Stainless steel 1.4301 (-V2)

Bowden cable (-BZ)

- for PUSH-1A/-02/-03/-04

adjustable damper (-DV1)

- Galvanised sheet steel (-SV, standard)
- Stainless steel 1.4301 (-V2)

Rubber lip seal (-GD1)

- Special rubber

Honeycomb air flow straightener (-WG1)

- Plastic

electric actuator (for PUSH-04)

- E048, 230 V AC, 3-point activation
- E047, 24 V AC, 3-point activation

METU flange UF

- Galvanised sheet steel (-MF1)
- Stainless steel 1.4301 (-MF2)

Tension ring, loose

- to connect Metu flange to counter flange
- made of galvanised steel (-SR1)
- made of stainless steel V2A / 1.4301 (-SR2)

Counter flange, loose

- for Metu flange.
- made of galvanised steel (-GF1)
- made of stainless steel V2A / 1.4301 (-GF2)

Flat flange to DIN 24154 / 5

- Galvanised sheet steel (-FF1)
- Stainless steel 1.4301 (-FF2)

### Fastening

Standard

- The displacement diffuser can be fitted directly to the ductwork.

## Displacement Diffuser Model PUSH

### Quick selection (horizontal throw)

NW	250	315	350/ 355	400	450	560	630
$L_{WA}$ [dB(A)]	45	45	45	45	45	45	45
$\Delta p_t$ (Pa)	48	41	32	28	32	32	39
$V_{zu}$ (m <sup>3</sup> /h)	730	1400	1450	1900	2400	3600	4500
$V_{zu}$ [l/s]	200	390	400	530	670	1000	1250

### Operating range of volumetric flow

NW	250	315	350/ 355	400	450	560	630
$V_{zu}$ min. (m <sup>3</sup> /h)	600	1200	1200	1500	2000	3000	3800
$V_{zu}$ max. (m <sup>3</sup> /h)	2200	4300	4500	6000	6800	11000	13000
$V_{zu}$ min. [l/s]	170	330	330	420	560	830	1060
$V_{zu}$ max. [l/s]	610	1190	1250	1670	1890	3060	3610

## Models and dimensions

### Air throw pattern

#### horizontal throw (cooling mode)

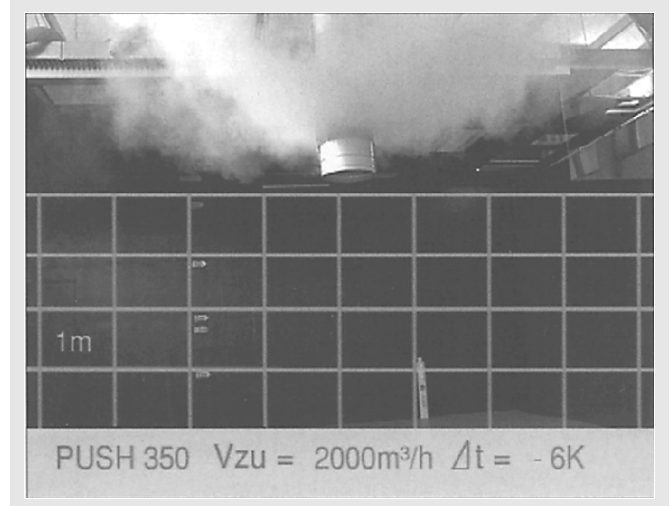

#### diagonally downward throw (isothermal)

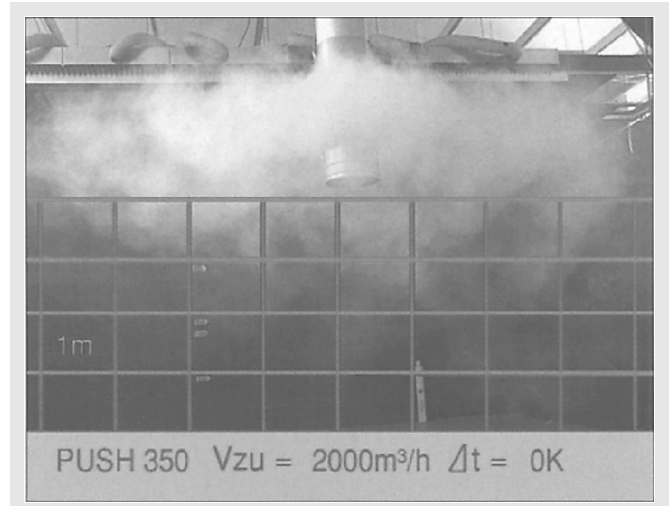

#### vertical throw (heating mode):

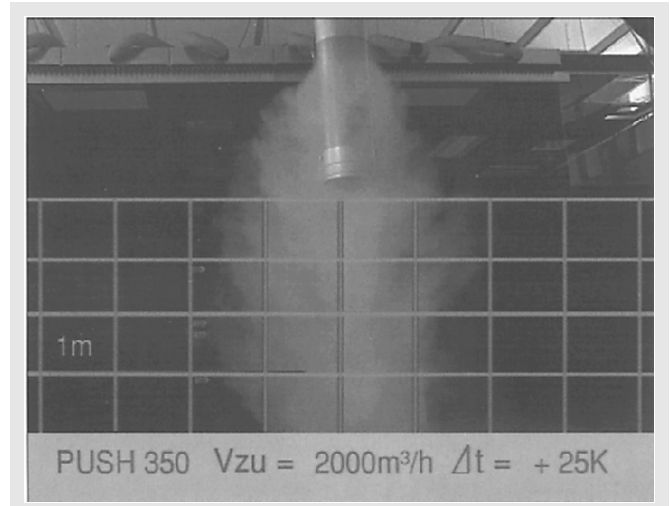

## Displacement Diffuser Model PUSH

Possible settings of the air throw pattern

	Air throw pattern					
PUSH-1A	↖	↗	↙	↘		
PUSH-1B	↖	↗	↙	↘		
PUSH-02	↖	↗	↙	↘	↓	↓
PUSH-03	↖	↗			↓	↓
PUSH-04	↖	↗	↙	↘	↓	↓
PUSH-5B	↖	↗			↓	↓
PUSH-06	↖	↗	↙	↘	↓	↓

Different throw patterns are achieved by rotating the adjustable baffle plate or base plate into different directions by means of the chain. Intermediate positions are also possible.

**horizontal throw: cooling mode**

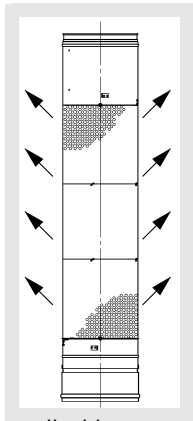

applicable to:  
PUSH-1A/-1B/-02/-03/  
-04/-5B/-06

**Vertical throw: Heating mode**

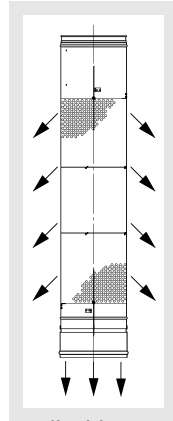

applicable to:  
PUSH-02/-03/-04/-5B/-06

**diagonally downward throw: isothermal**

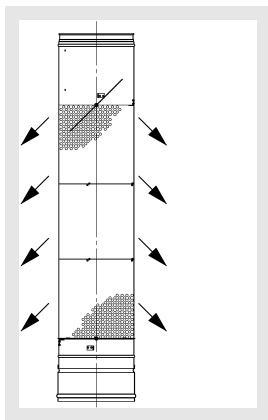

applicable to:  
PUSH-1A/-1B/-02/-04/-06

# Displacement Diffuser Model PUSH

## Dimensions

**PUSH-1A**

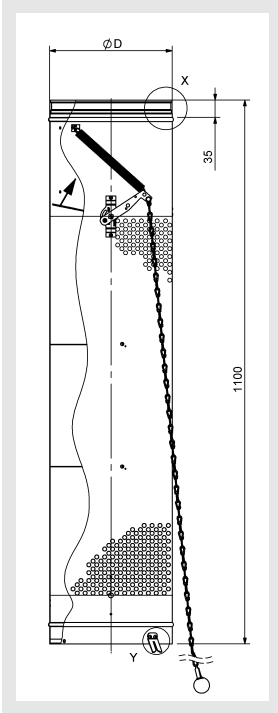

**PUSH-1B**

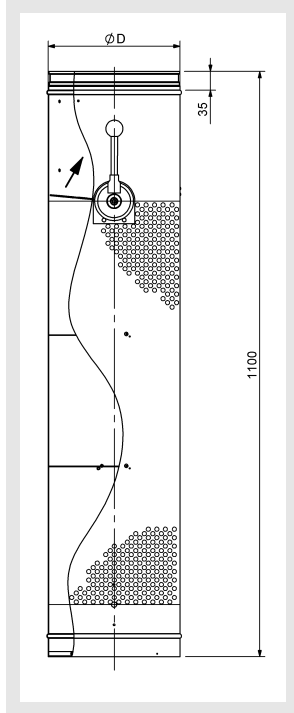

**PUSH-02**

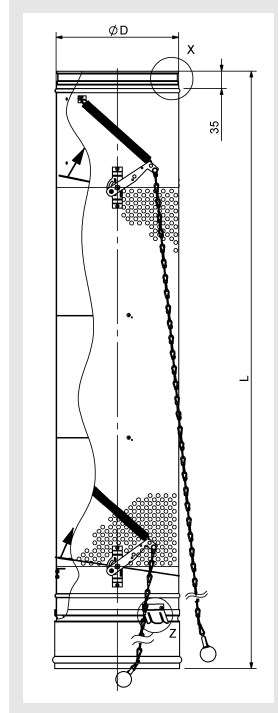

**PUSH-03**

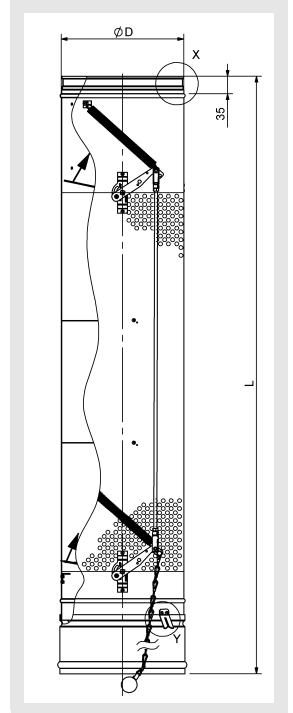

**PUSH-04**

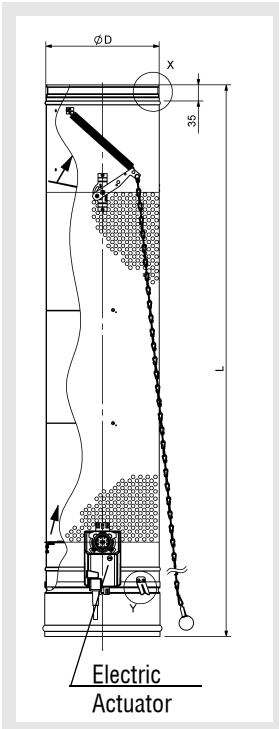

**PUSH-5B**

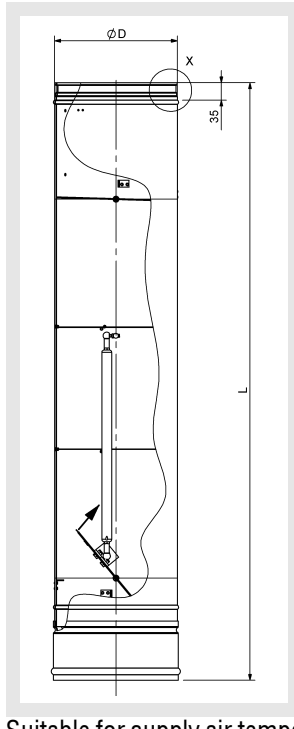

**PUSH-6**

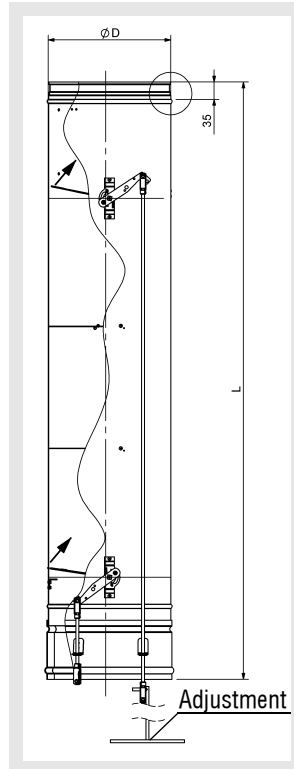

Suitable for supply air temperatures of approx. 15°C to max. 40°C.

### Available sizes

NW	250	315	350	355	400	450	560	630
$\varnothing D$	248	313	348	353	398	448	558	628
L	1220			1250		1300	1350	

## Displacement Diffuser Model PUSH

### Actuators for PUSH-04

	Actuator
-E048	Belimo NM230A-F
-E047	Belimo NM24A-F

### Locking mechanism (-AA)

#### Detail Y

for PUSH-1A/-03/-04

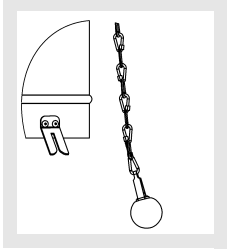

#### Detail Z

for PUSH-02

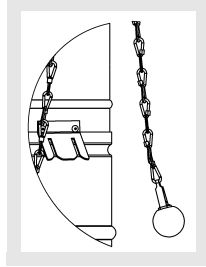

### Locking plate (-AW)

for PUSH-1A/-02/-03/-04

on walls / columns

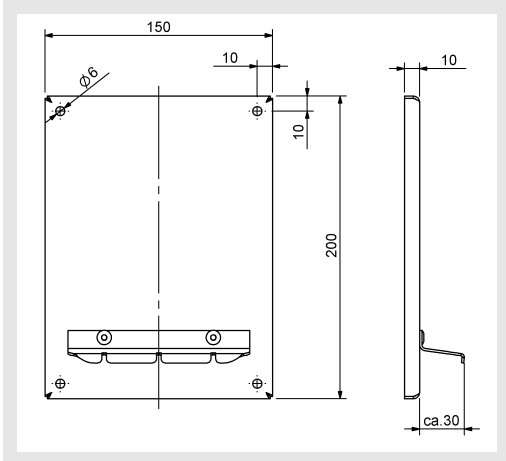

### Bowden cable (-BZ)

for PUSH-1A/-02/-03/-04

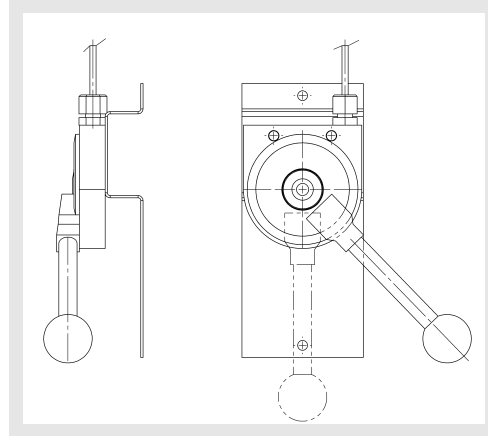

### Air throw setting (for PUSH-1A/-02/-03/-04):

#### at the diffuser casing (with locking mechanism -AA):

- Adjustable by chain. 3 m long from bottom edge of diffuser.

#### On walls / columns (with locking plate -AW / with Bowden cable -BZ):

- Adjustable by chain / cable. 3 m long from bottom edge of diffuser. Chain approx. 30 cm long.



# Displacement Diffuser Model PUSH

## Accessories - dimensions

adjustable damper (-DV1)  
or adjustable damper with honeycomb air flow straightener (-DV2)

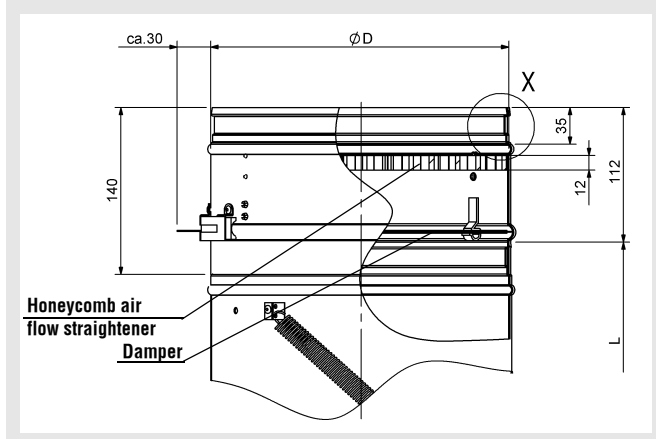

With adjustable damper with honeycomb air flow straightener (-DV2), the honeycomb air flow straightener is fitted directly into the damper.

## Honeycomb air flow straightener (-WG1)

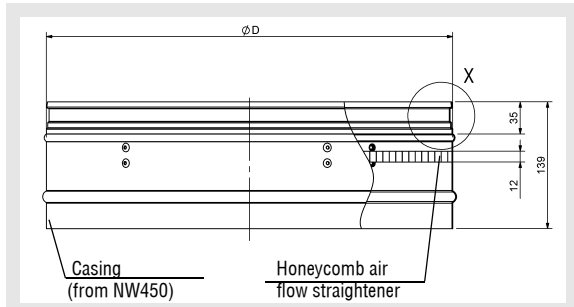

If the honeycomb air flow straightener (-WG1) is ordered without damper, up to and including NW 450, it is fitted into the diffuser. From NW 450 upwards, it is fitted into a separate casing.

## Free cross-section (-DV1)



"OPEN" position: FQ approx. 75%

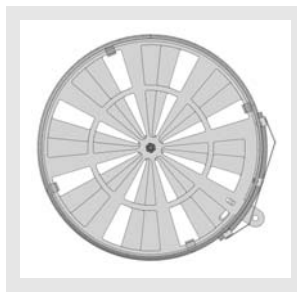

"CLOSED" position: FQ approx. 25%

## Rubber lip seal (-GD1)

Detail X

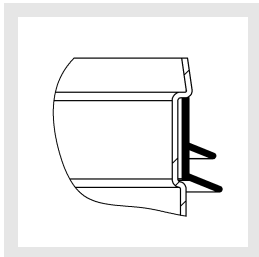

## 1/4 cover (-AD1/-AD2)

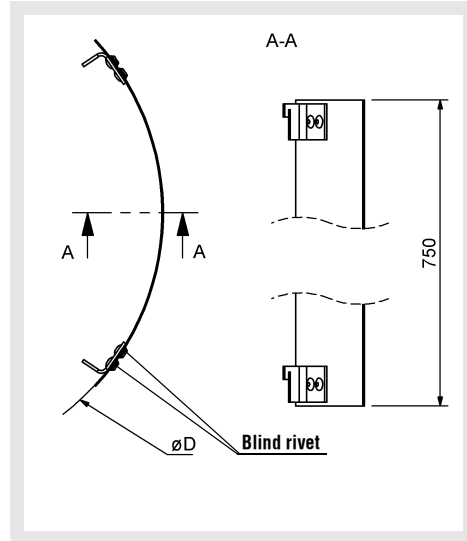

For subsequent change of the air throw angle from 360° to 270° (for PUSH-...-360-... throw only).

After mounting the cover plate correctly, the M8 screws have to be screwed into the perforation of the PUSH diffuser for security!

## METU flange

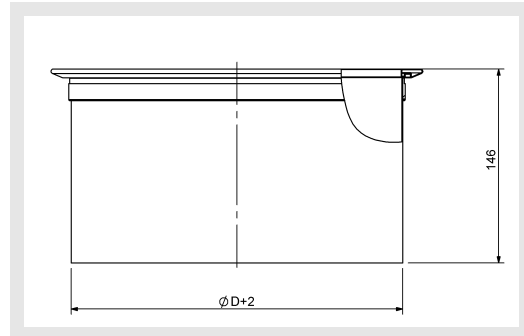

- Galvanised sheet steel (-MF1)
- Stainless steel 1.4301 (-MF2)

Please note!

Tension ring and counter flange must be ordered separately!

## Flat flange

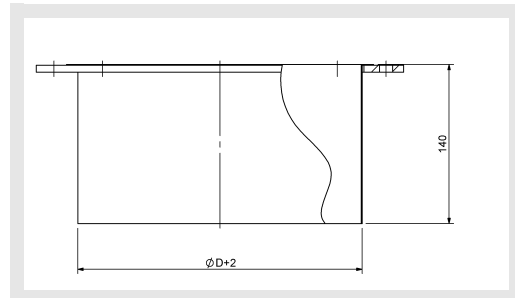

- Galvanised sheet steel (-FF1)
- Stainless steel 1.4301 (-FF2)

## Displacement Diffuser Model PUSH

### Installation options

Suspended installation (-F) (standard)

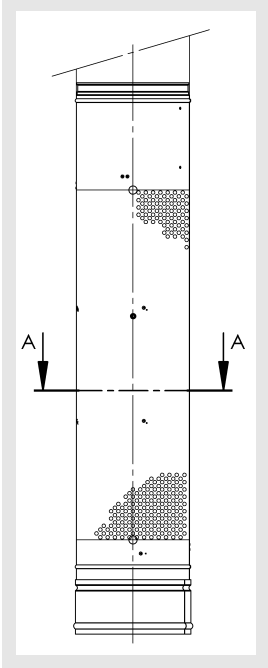

Section A-A

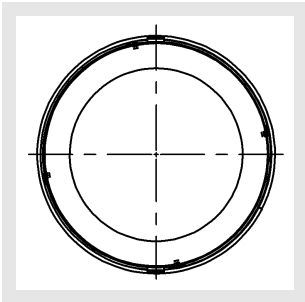

Wall / column installation (-W)

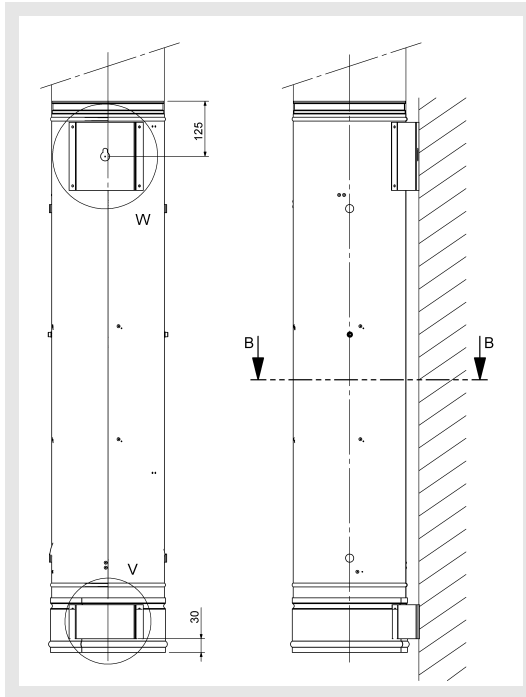

Section B-B

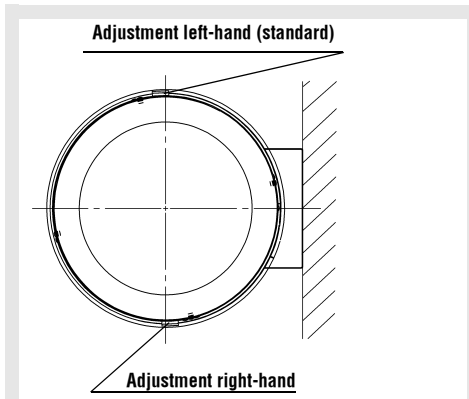

Adjustment for type PUSH-1A/-1B/-02/-03/-04/-06.

Detail W

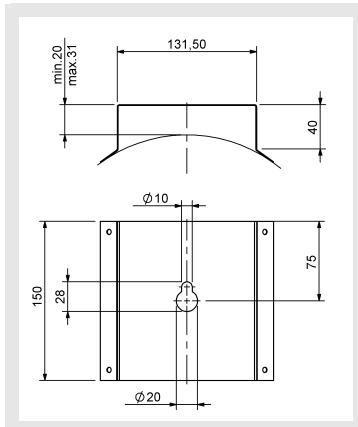

Detail V

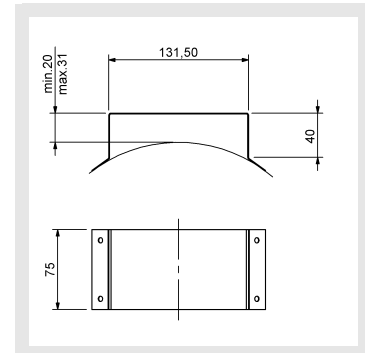

# Displacement Diffuser Model PUSH

## Technical data

### Pressure loss and noise level

#### PUSH-...-250-...

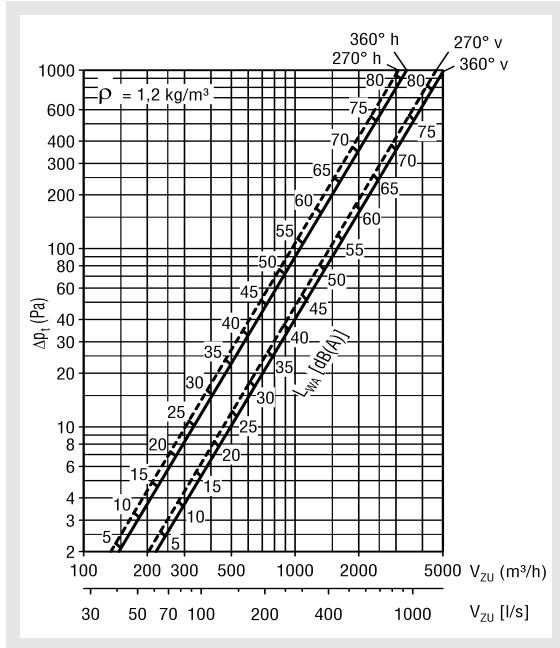

#### PUSH-...-350/355-...

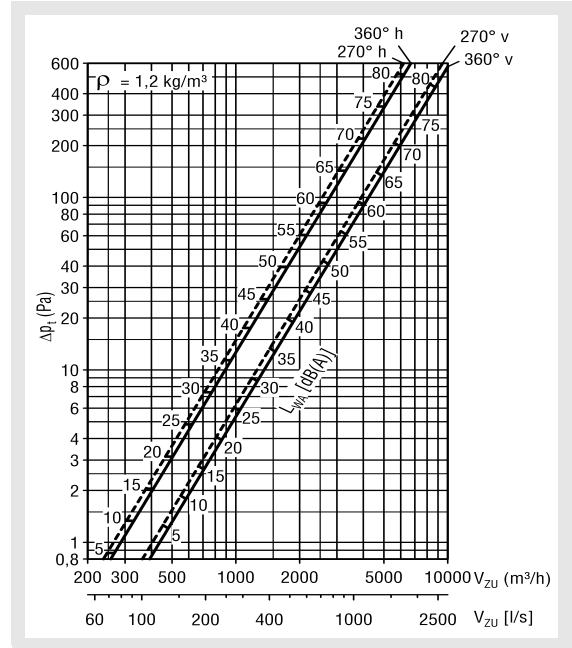

#### PUSH-...-315-...

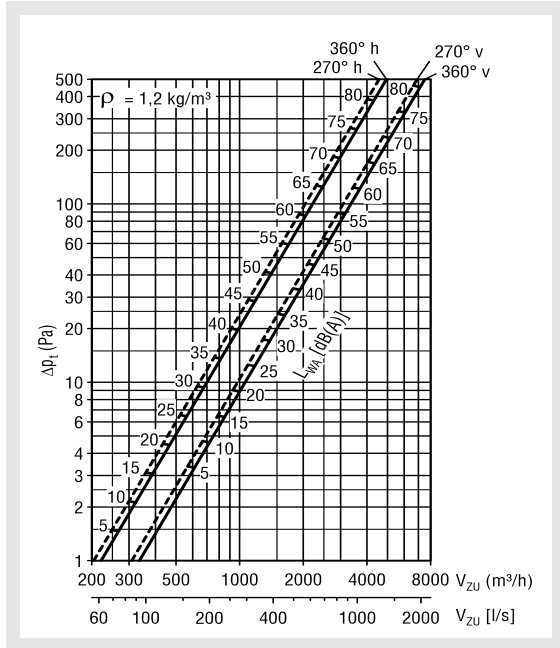

#### PUSH-...-400-...

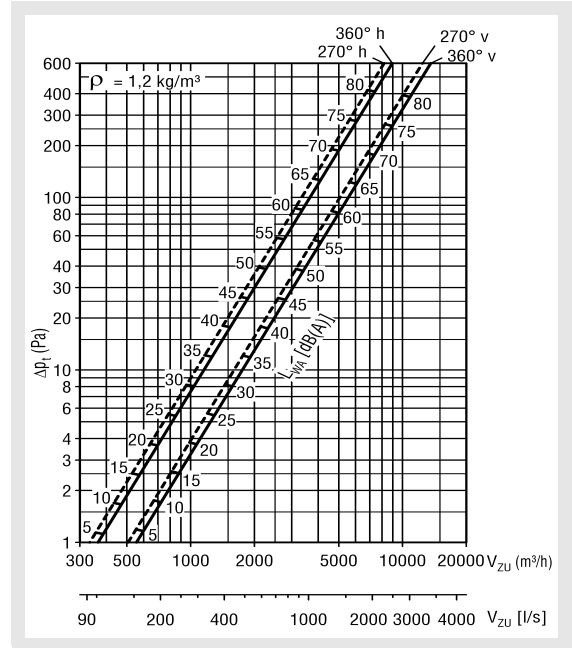

h = horizontal  
v = vertical

--- 270° throw for wall / column installation

# Displacement Diffuser Model PUSH

PUSH-...-450-...

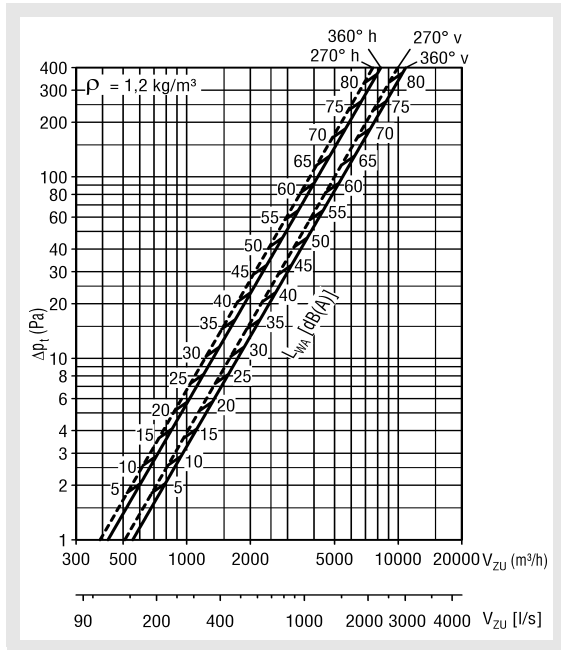

PUSH-...-630-...

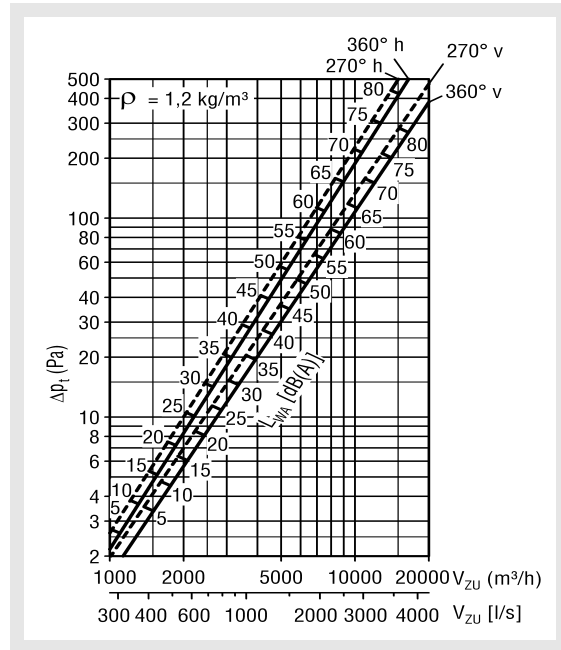

PUSH-...-560-...

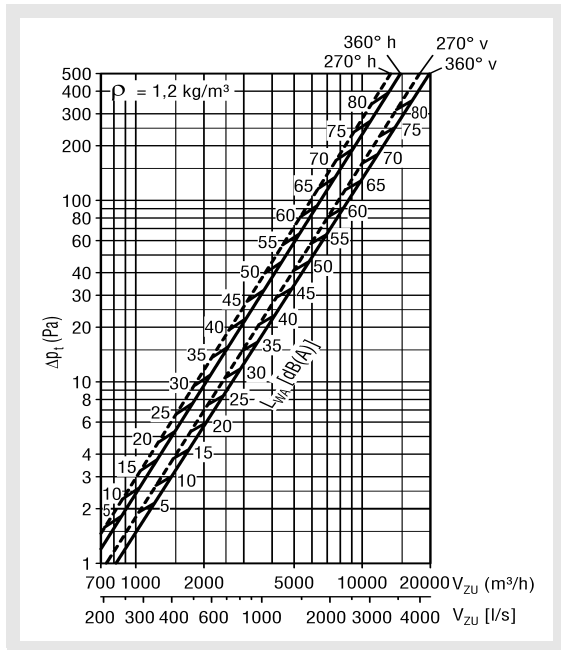

Correction factor for damper adjustment (-DV1)

	NW	250	315	350/355	400	450	560	630
100%	L <sub>WA</sub>	x1.2	x1.2	x1.3	x1.3	x1.4	x1.4	x1.5
	Δp <sub>t</sub>	x2.3	x3.0	x3.5	x3.8	x4.0	x4.2	x4.3
66%	L <sub>WA</sub>	x1.4	x1.5	x1.5	x1.6	x1.6	x1.7	x1.7
	Δp <sub>t</sub>	x6.4	x6.8	x7.1	x7.3	x7.4	x7.5	x7.5
33%	L <sub>WA</sub>	x1.7	x1.9	x2.1	x2.4	x2.6	x2.8	x3.0
	Δp <sub>t</sub>	x10	x13	x14	x15	x15	x15	x15

The correction factors refer to the sound power level L<sub>WA</sub> with horizontal air throw pattern.  
Damper position OPEN in %

h = horizontal  
v = vertical  
- - - - 270° throw for wall / column installation

## Displacement Diffuser Model PUSH

Relative sound power spectrum:

<b>PUSH in all variants and sizes, without damper</b>														
Relative sound power spectrum														
	<b>horizontal</b>							<b>vertical</b>						
Frequency Hz	125	250	500	1000	2000	4000	8000	125	250	500	1000	2000	4000	8000
Correction value KL	0,4	2,0	-0,5	-5,0	-9,3	-19,7	-22,6	3,4	2,1	-0,6	-8,1	-16,4	-21,9	-24,1

<b>PUSH in all variants and sizes, with damper</b>														
Relative sound power spectrum														
	<b>horizontal</b>							<b>vertical</b>						
	<b>33%</b>							<b>33%</b>						
Frequency Hz	125	250	500	1000	2000	4000	8000	125	250	500	1000	2000	4000	8000
Correction value KL	-0,3	0,6	-3,0	-6,2	-11,0	-16,3	-21,5	-3,3	-1,1	-3,3	-5,5	-9,8	-15,8	-21,3
	<b>66%</b>							<b>66%</b>						
Frequency Hz	125	250	500	1000	2000	4000	8000	125	250	500	1000	2000	4000	8000
Correction value KL	3,8	3,0	-1,6	-8,1	-14,2	-18,9	-23,3	0,6	1,4	-3,0	-6,9	-11,3	-15,2	-21,5
	<b>100%</b>							<b>100%</b>						
Frequency Hz	125	250	500	1000	2000	4000	8000	125	250	500	1000	2000	4000	8000
Correction value KL	3,4	3,1	-0,5	-8,2	-15,6	-20,9	-23,9	2,4	2,5	-1,6	-7,2	-13,6	-18,6	-22,7

# Displacement Diffuser Model PUSH

## Maximum end velocity of jet

### PUSH-...-250-...

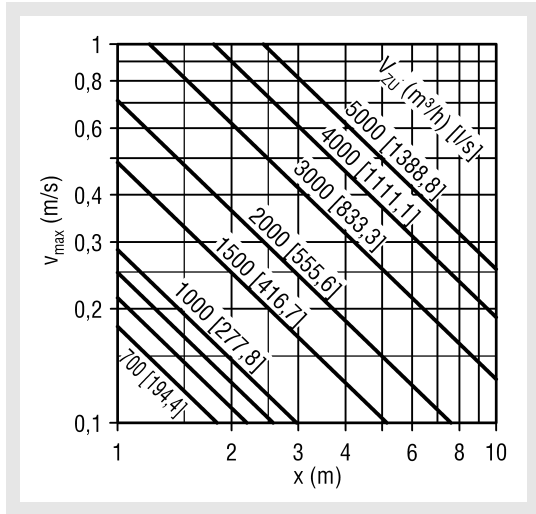

270° throw for wall / column installation:

$$V_{max\ 270^\circ} = V_{max} \times 1.8$$

### PUSH-...-350/355-...

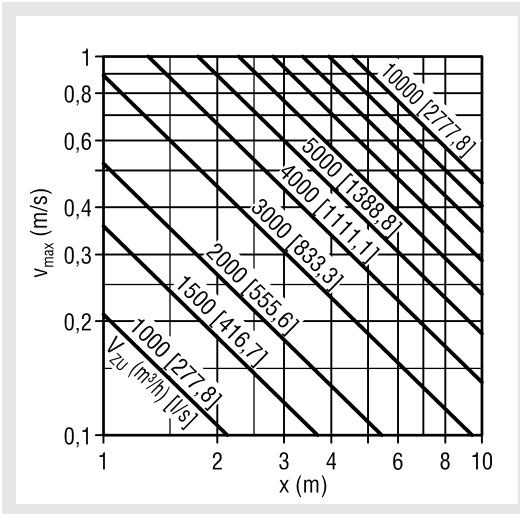

270° throw for wall / column installation:

$$V_{max\ 270^\circ} = V_{max} \times 1.8$$

### PUSH-...-315-...

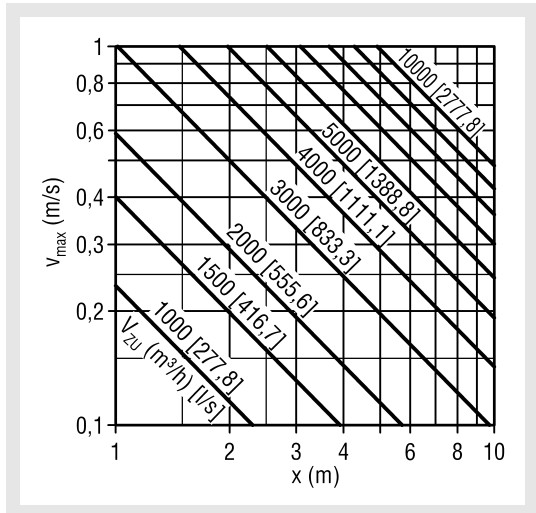

270° throw for wall / column installation:

$$V_{max\ 270^\circ} = V_{max} \times 1.8$$

### PUSH-...-400-...

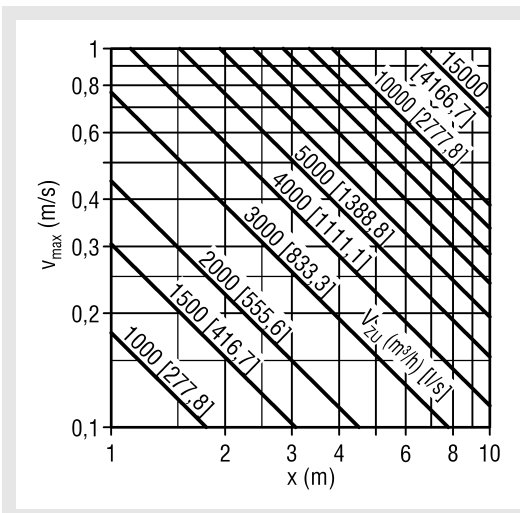

270° throw for wall / column installation:

$$V_{max\ 270^\circ} = V_{max} \times 1.8$$

# Displacement Diffuser Model PUSH

## PUSH-...-450-...

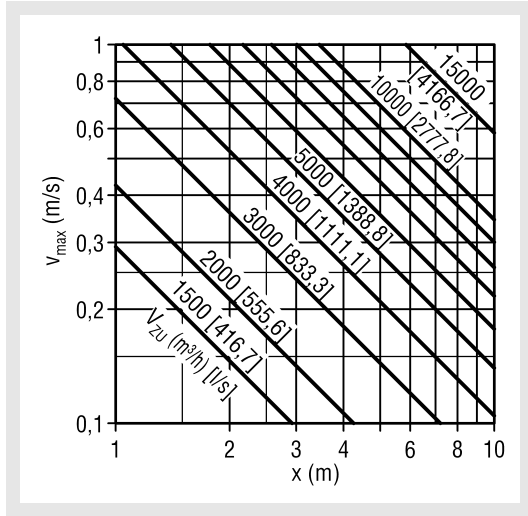

270° throw for wall / column installation:

$$V_{max\ 270^\circ} = v_{max} \times 1$$

## PUSH-...-630-...

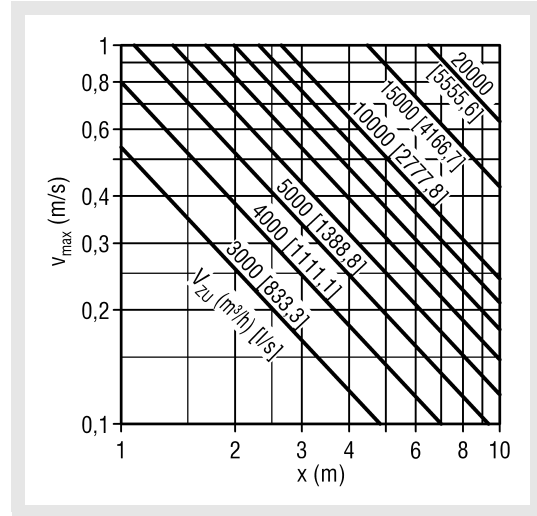

270° throw for wall / column installation:

$$V_{max\ 270^\circ} = v_{max} \times 1.8$$

## PUSH-...-560-...

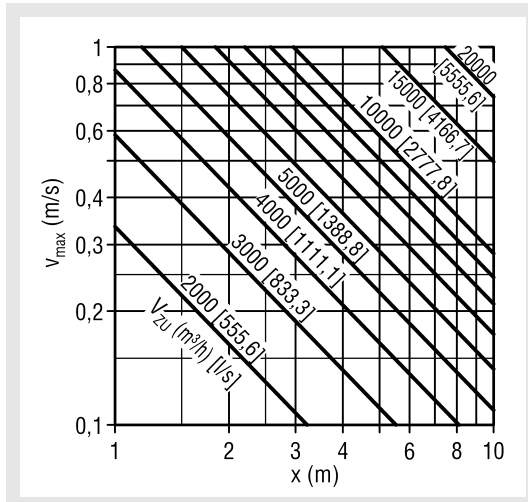

270° throw for wall / column installation:

$$V_{max\ 270^\circ} = v_{max} \times 1.8$$

# Displacement Diffuser Model PUSH

## Jet path

Suspended installation (-F), 360° throw (cooling mode)

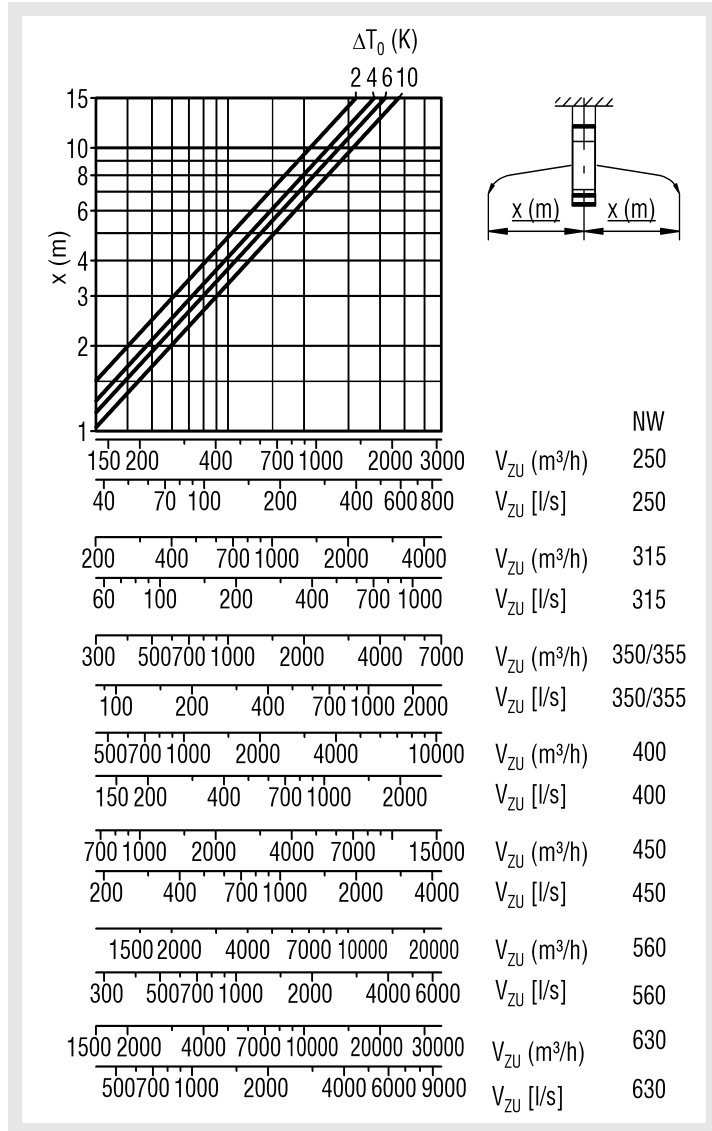



# Displacement Diffuser Model PUSH

Wall / column installation (-W), 270° throw (cooling mode)

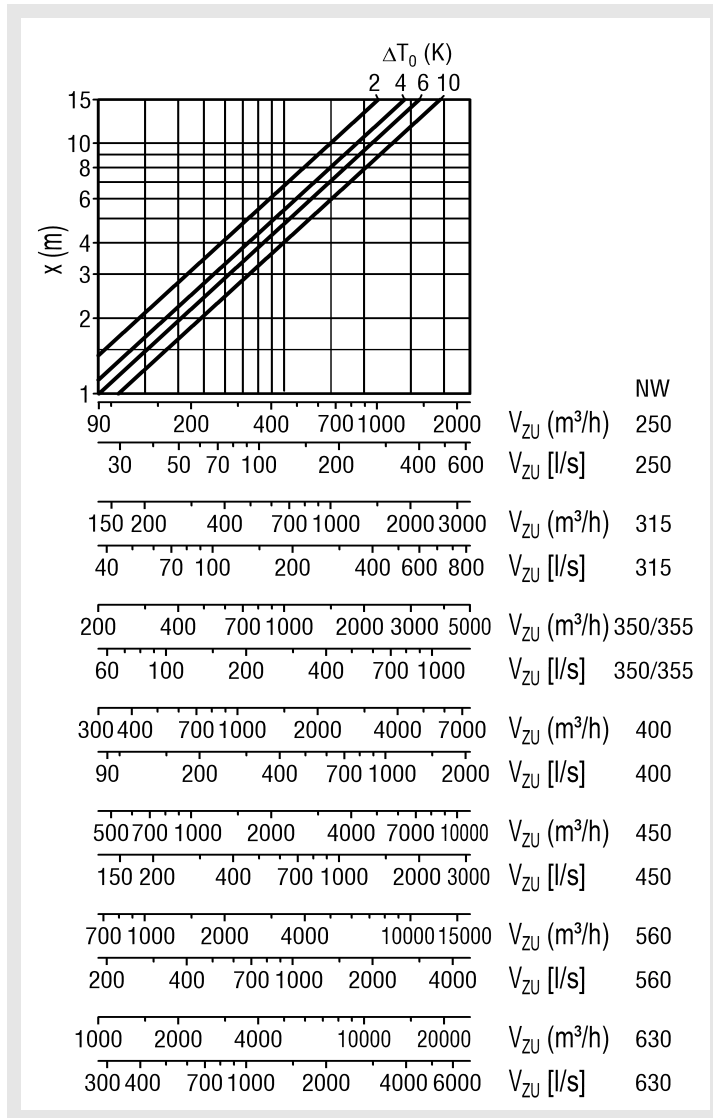

NW

V<sub>ZU</sub> (m³/h) 250

V<sub>ZU</sub> [l/s] 250

V<sub>ZU</sub> (m³/h) 315

V<sub>ZU</sub> [l/s] 315

V<sub>ZU</sub> (m³/h) 350/355

V<sub>ZU</sub> [l/s] 350/355

V<sub>ZU</sub> (m³/h) 400

V<sub>ZU</sub> [l/s] 400

V<sub>ZU</sub> (m³/h) 450

V<sub>ZU</sub> [l/s] 450

V<sub>ZU</sub> (m³/h) 560

V<sub>ZU</sub> [l/s] 560

V<sub>ZU</sub> (m³/h) 630

V<sub>ZU</sub> [l/s] 630

## Displacement Diffuser Model PUSH

### Vertical throw (in heating mode)

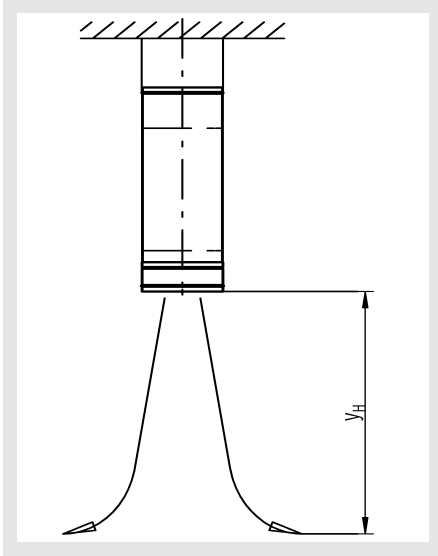

PUSH-...-250-...

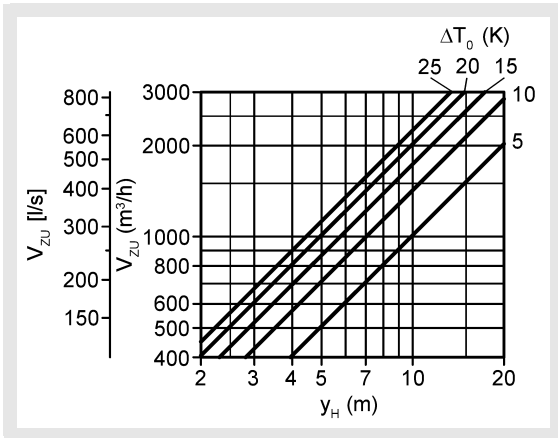

PUSH-...-350/355-...

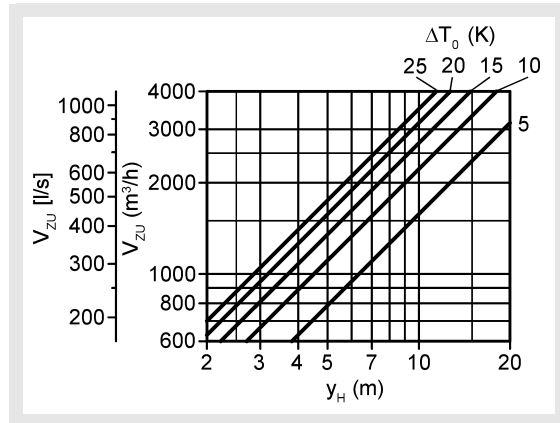

PUSH-...-315-...

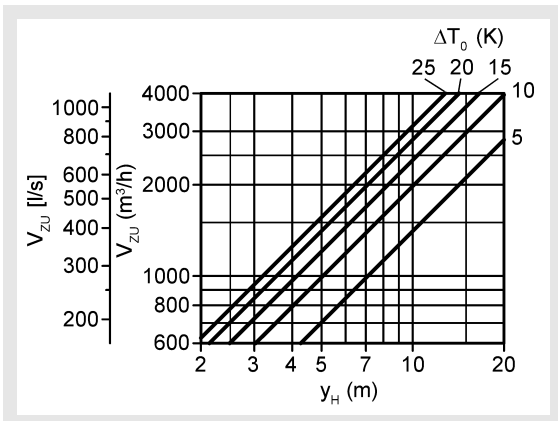

PUSH-...-400-...

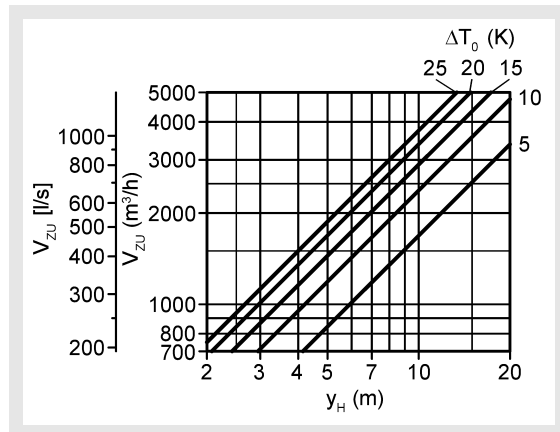

# Displacement Diffuser Model PUSH

**PUSH-...-450-...**

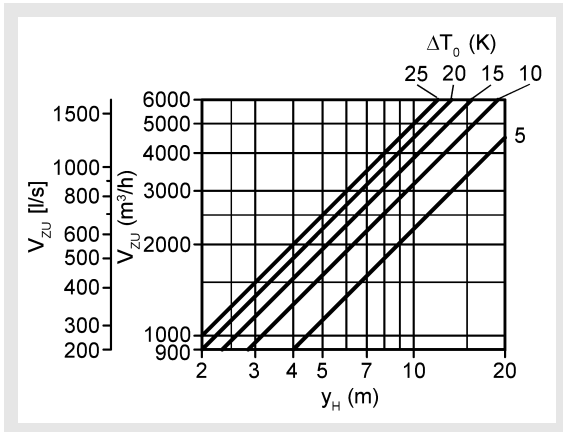

**PUSH-...-630-...**

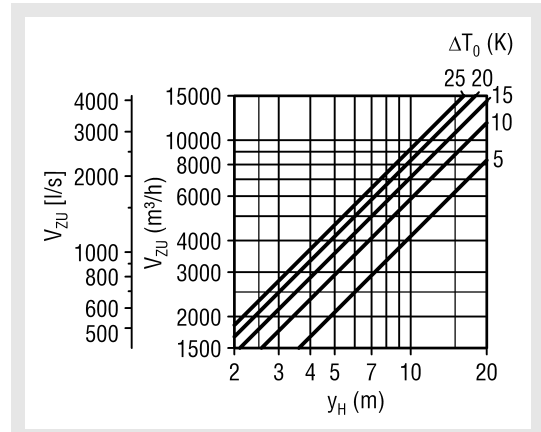

**PUSH-...-560-...**

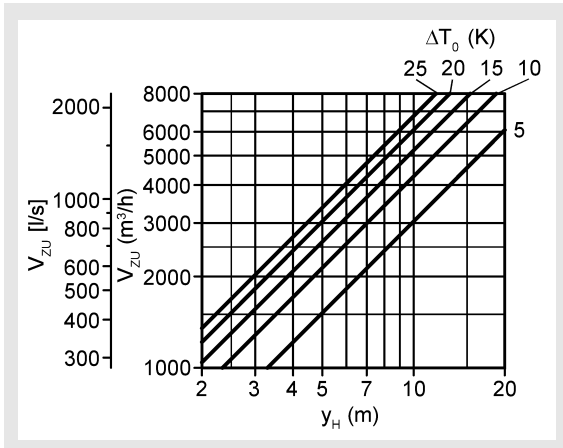

## Displacement Diffuser Model PUSH

### Induction ratio

(only applicable with horizontal throw)

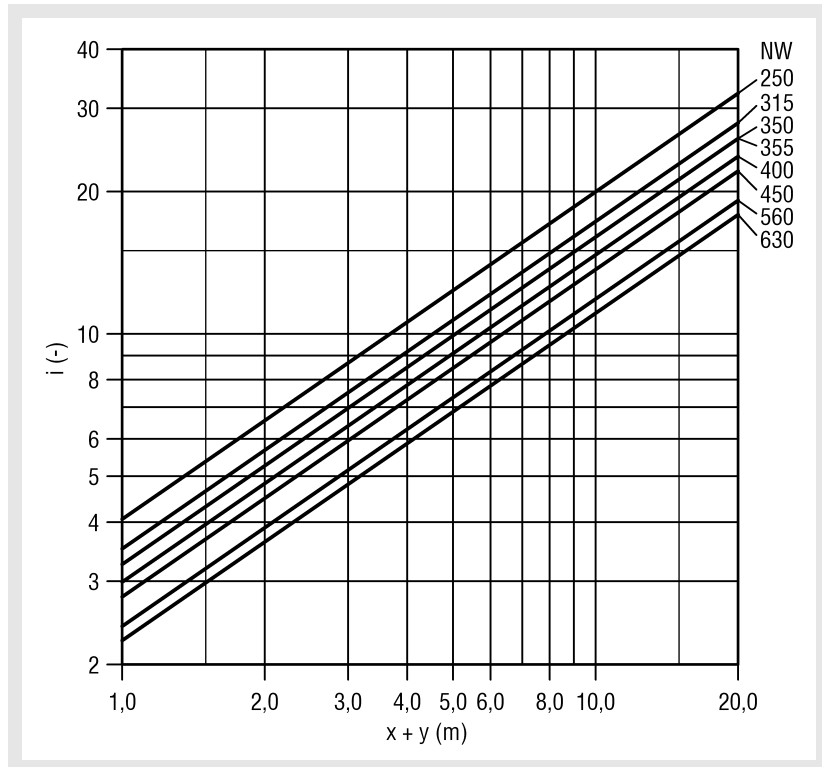

Correction factor for 270° throw =  $i(-) \times 0.714$

### Temperature ratio

(only applicable with horizontal throw)

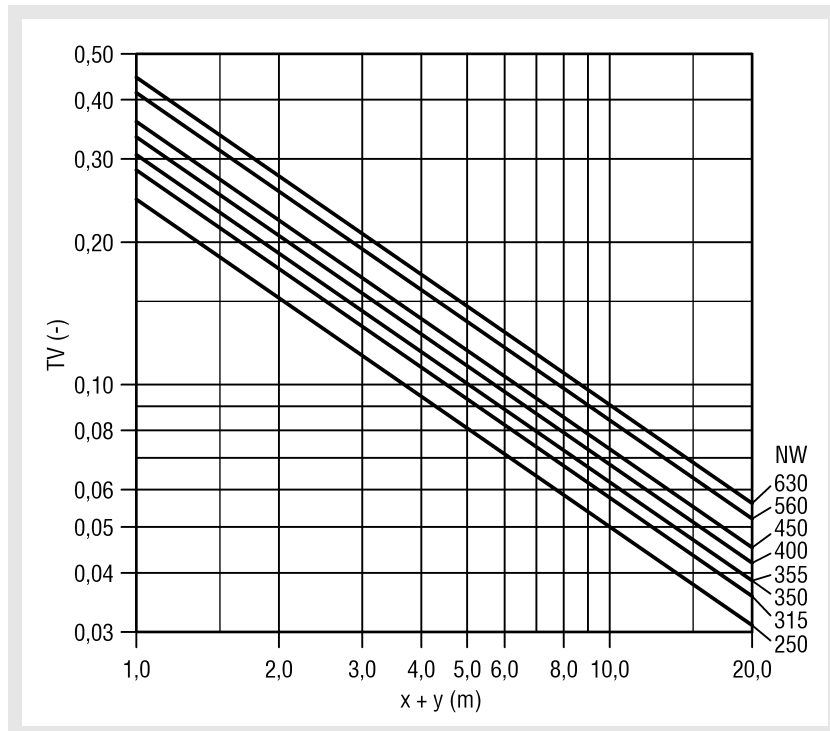

Correction factor for 270° throw =  $TV(-) \times 1.4$

## Displacement Diffuser Model PUSH

### Connection diagrams of electric actuators

Make Belimo

-E048 (NM230A-F) / -E047 (NM24A-F)

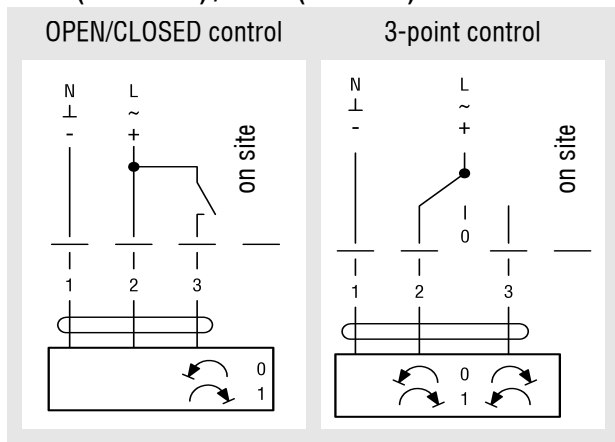

### Legend

$V_{ZU}$ (m <sup>3</sup> /h)	= Supply air volume
$V_{ZU}$ [l/s]	= Supply air volume
$\Delta T_0$ (K)	= Temperature difference between supply air temperature and room temperature ( $\Delta T_0 = t_{ZU} - t_R$ )
$t_{ZU}$ (°C)	= Air supply temperature
$t_R$ (°C)	= Room temperature
$y_H$ (m)	= Maximum penetration in heating mode
$x$ (m)	= horizontal throw
$v_{max}$ (m/s)	= Maximum end velocity of jet
$v_{mittel}$ (m/s)	= Average end velocity of jet ( $v_{mittel} = v_{max} \times 0.5$ )
$\Delta p_t$ (Pa)	= Pressure loss
$L_{WA}$ [dB(A)]	= A-weighted sound power level
$\rho$ (kg/m <sup>3</sup> )	= Density
$h$ (-)	= horizontal
$v$ (-)	= vertical
NW (mm)	= Nominal width

### Technical data of electric actuators

-E048 product Belimo (NM230A-F)

Rated voltage:	AC 100 ... 240 V, 50 / 60 Hz
Functional range:	AC 85 ... 265 V
Power consumption	
- Operation:	2.5 W @ nominal torque
- Idle position:	0.6 W
- Dimensioning:	5.5 VA
Torque	
(rated torque):	Min. 10 Nm at the rated voltage
Running time:	150 s / 90°
Sound power level:	max. 35 dB (A)
Protection class:	II protective insulation <input checked="" type="checkbox"/>
Degree of protection:	IP54 in all mounting positions
EMC:	CE according to 89 / 336 / EEC
Low voltage directive:	CE according to 73 / 23 / EEC
Ambient temperature:	-30 ... +50°C

-E047 product Belimo (NM24A-F)

Rated voltage:	AC 24 V / DC 24 V, 50 / 60 Hz
Functional range:	AC / DC 19.2 ... 28.8 V
Power consumption	
- Operation:	1.5 W @ nominal torque
- Idle position:	0.2 W
- Dimensioning:	3.5 VA
Torque	
(rated torque):	Min. 10 Nm at the rated voltage
Running time:	150 s / 90°
Sound power level:	max. 35 dB (A)
Protection class:	III safety extra low voltage
Degree of protection:	IP54 in all mounting positions
EMC:	CE according to 89 / 336 / EEC
Ambient temperature:	-30 ... +50°C

## Displacement Diffuser Model PUSH

### PUSH order code

01	02	03	04	05	06
Type	Model	Nominal width	Material	Paint	Air throw angle
<b>Example</b>					
PUSH	-1A	-250	-SV	-9010	-360

07	08	09	10	11	12
Installation	Air flow direction adjustment	Actuator	Damper	Duct connection	Cover
-W	-AA	-E000	-DV1	-GD1	-AD0

All fields must be filled when ordering.

#### Sample

**PUSH-1A-250-SV-9010-360-W-AA-E000-DV1-GD1-AD0**

Displacement diffuser PUSH | upper baffle plate adjustable by chain, closed base | ø248 mm | galvanised sheet steel | painted to the RAL colour 9010 (white) | 360° throw | wall / column installation | with locking mechanism on diffuser casing | without electric actuator | with adjustable damper for air volume regulation with side adjustment lever | with rubber lip seal | without ¼ cover

#### Order details

##### 01 - Type

PUSH = Displacement Diffuser Model PUSH

##### 02 - Model

- 1A = upper baffle plate adjustable by chain, closed base
- 1B = upper baffle plate adjustable with Magura lever, bottom closed
- 02 = upper baffle plate and base plate individually adjustable by chain
- 03 = upper baffle plate and base plate jointly adjustable by chain
- 04 = upper baffle plate adjustable by chain and base plate by electric actuator
- 5B = base plate adjustable by thermocouple and upper baffle plate fixed
- 06 = upper baffle plate and base plate individually adjustable by adjustment rod

##### 03 - Nominal width

- 250 = ø248 mm
- 315 = ø313 mm
- 350 = ø348 mm
- 355 = ø353 mm
- 400 = ø398 mm
- 450 = ø448 mm
- 560 = ø558 mm
- 630 = ø628 mm

##### 04 - Material

- SV = galvanised sheet steel
- V2 = stainless steel 1.4301 (V2A)

##### 05 - Paint

- 0000 = Without paint (standard)
- SAND = Painted in the colour sand silver (standard for stainless steel)
- xxxx = RAL colour can be freely selected (always with 4 digits)

##### 06 - Air throw angle

- 270 = 270° throw
- 360 = 360° throw (standard)

##### 07 - Installation

- F = Suspended installation (standard)
- W = Wall / column installation

##### 08 - Air flow direction adjustment

- A0 = without locking mechanism
- AA = with locking mechanism at the diffuser casing (standard)
- AW = with locking plate on walls / columns (only PUSH-1A/-02/-03/-04)
- BZ = with Bowden cable on walls / columns (only PUSH-1A/-02/-03/-04)

## Displacement Diffuser Model PUSH

### 09 - Actuator

- E000 = without electric actuator
- E047 = with electric actuator 24V AC, (only PUSH-04)
- E048 = with electric actuator 230V AC, (only PUSH-04)

### 10 - Air volume regulation

- DV0 = Without damper (standard)
- DV1 = with adjustable damper for air volume regulation, with side adjustment lever
- DV2 = with adjustable damper for air volume regulation, with side adjustment lever with honeycomb air flow straightener
- WG1 = with honeycomb air flow straightener

### 11 - Duct connection

- KA0 = without rubber lip seal / without flange (standard)
- GD1 = with rubber lip seal
- FF1 = with flat flange, galvanised sheet steel
- FF2 = with flat flange, stainless steel 1.4301
- MF1 = with METU flange, galvanised sheet steel
- MF2 = with METU flange, stainless steel 1.4301

Please note!

Tension ring and counter flange must be ordered separately and are supplied loose!

### 12 - Cover

- AD0 = without ¼ cover (standard)
- AD1 = with ¼ cover for subsequent change of the air throw angle from 360° to 270°, galvanised sheet steel
- AD2 = with ¼ cover for subsequent change of the air throw angle from 360° to 270°, stainless steel 1.4301

## Displacement Diffuser Model PUSH

### Specification texts

Displacement diffuser type PUSH suitable for ventilation and air-conditioning of industrial plants and assembly shops. For optimum use of space, a mounting height of 3-4 m is recommended. Installation at floor level is possible. The diffuser can be mounted freely suspended in rooms or mounted to walls or columns. With isothermal supply air pattern, the displacement diffuser can be used both for cooling at a temperature difference of max. -10 K and for heating at a temperature difference of max. +25 K. In cooling mode and with isothermal supply air pattern, the diffuser works with low exit velocities and is distinguished by laminar displacement flow. In heating mode, the diffuser guarantees an efficient heating phase with the base plate open. The adjustment of the aerodynamically shaped baffle plate and the optional adjustment of the base plate allow the throw pattern to be adjusted to individual requirements. Air throw patterns ranging from diagonally upwards to horizontal, diagonally downwards and vertical are possible.

The optionally adjustable base plate with damper leaf seal made of PUR can be closed air-tight, in order to prevent a vertical throw of cold supply air in cooling mode. The diffuser can be connected directly to round ductwork.

It consists of a perforated diffuser casing, adjustable baffle and base plates made of galvanised sheet steel.

#### Models:

- PUSH-1A: upper baffle plate adjustable by chain, closed base.
- PUSH-1B: Upper baffle plate with Magura lever mounted to impact ring axis adjustable, closed base.
- PUSH-02: upper baffle plate and base plate with damper leaf seal individually adjustable by chain.
- PUSH-03: upper baffle plate and base plate with damper leaf seal jointly adjustable by chain.
- PUSH-04: upper baffle plate adjustable by chain and base plate with damper leaf seal adjustable by electric actuator (3-point activation).  
-E048: 230 V AC  
-E047: 24 V AC
- PUSH-5B: Base plate with damper leaf seal adjustable by thermocouple, upper baffle plate fixed Thermocouple suitable for supply air temperatures of approx. 15°C to max. 40°C.
- PUSH-06: upper baffle plate and base plate with damper leaf seal individually adjustable by adjustment rod.

Air throw setting (for PUSH-1A/-02/-03/-04):

- at the diffuser casing with locking mechanism (-AA)
- on walls / columns:
  - with locking plate (-AW)
  - with self-locking Bowden cable (-BZ)

Installation situation:

- Suspended installation (-F), 360° throw, standard
- Wall / column installation (-W)
  - 360° throw (-360)
  - 270° throw (-270)

Product: SCHAKO type PUSH

#### Accessories:

- Adjustable damper (-DV1) for air volume regulation, with side adjustment lever made of galvanised sheet steel
- Adjustable damper (-DV2) with honeycomb air flow straightener for air volume regulation, with side adjustment lever made of galvanised sheet steel
- Plastic honeycomb air flow straightener (-WG1)
- Rubber lip seal (-GD1), made of special rubber.
- Metu flange duct flange UF with tension ring SR (-MF1/-MF2)
- Tension ring to connect Metu flange and counter flange, loose.
  - made of galvanised steel (-SR1)
  - made of stainless steel V2A / 1.4301 (SR2)
- Counter flange for Metu flange, loose.
  - made of galvanised steel (-GF1)
  - made of stainless steel V2A / 1.4301 (GF2)
- Flat flange to DIN 24154 / 5 (-FF1/-FF2)
- ¼ cover (-AD1/-AD2) for subsequent change of the air throw angle from 360° to 270° (for PUSH-...-360 throw only)

#### Please note!

**Tension ring and counter flange must be ordered separately and are supplied loose!**