



# Ceiling impulse diffuser

## Model PIL



SCHAKO KG  
Steigstraße 25-27  
D-78600 Kolbingen  
Telephone +49 (0) 74 63 - 980 - 0  
Fax +49 (0) 74 63 - 980 - 200  
[info@schako.de](mailto:info@schako.de)  
[schako.com](http://schako.com)

# Ceiling Impulse Diffuser Model PIL

## Contents

<b>Description</b> .....	<b>3</b>
Construction .....	4
Model .....	4
Fastening .....	4
Accessories .....	5
<b>Models and dimensions</b> .....	<b>6</b>
Dimensions .....	6
Accessories - dimensions .....	8
Fastening methods .....	9
<b>Technical data of PIL-N-...</b> .....	<b>10</b>
Pressure loss and noise level .....	10
Maximum end velocity of jet .....	12
Critical throw .....	13
PIL-N-...-Z-... induction ratio .....	14
PIL-N-...-Z-... temperature ratio .....	14
<b>Technical data of PIL-G-...</b> .....	<b>15</b>
Pressure loss and noise level .....	15
Maximum end velocity of jet .....	16
Critical throw .....	17
PIL-G-...-Z-... induction ratio .....	18
PIL-G-...-Z-... temperature ratio .....	18
<b>Legend</b> .....	<b>18</b>
<b>Order code PIL</b> .....	<b>19</b>
<b>Order code SK</b> .....	<b>20</b>
<b>Specification texts</b> .....	<b>22</b>

## Ceiling Impulse Diffuser Model PIL

### Description

The ceiling impulse diffuser type PIL-... has been specially designed for use **in clean rooms, operating theatres and comfort rooms up to heights of 4m**. It produces a **pulsating horizontal jet stream**. The supply air is discharged along the ceiling and, upon reaching the critical throw length, gradually sinks into the occupied zone at low velocity. The pulsating air pattern results in an **efficient reduction of the velocity and of the temperature difference in the air jet**. A displacement flow is created near the diffuser, which means the ceiling and diffuser itself are less prone to particles depositing on the outlet or near the ceiling. An integrated air guide funnel ensures that the supply air is discharged uniformly across the whole face of the diffuser. The diffuser can be used for cooling with a maximum temperature difference of -15K. A freely suspended installation is possible for sizes 500 and 600/625 up to a  $\Delta T$  of -4K. Size 400 needs a size 500 faceplate for freely suspended installation. The air guide funnel of PIL-G has been modified to allow a throughput of much **higher air volumes** (about +50%), compared with PIL, at the **same noise level** and at **lower pressure losses** (about -30%). This means a **saving** on ceiling impulse diffusers in case of a similar supply air volume. Reducing the number of diffusers automatically reduces the mounting and regulation costs.

The regular cleaning of the air diffuser required in clean rooms and operating theatres can be done easily and quickly due to the smooth surface of the front plate. The ceiling impulse diffuser can be used for supply and exhaust air. The ceiling impulse diffuser is connected to the duct system with a plenum box type SK-Q-... for the square model or type SK-R-... for round models. The supply air plenum box is fitted with an equalising grid, to ensure a certain admission pressure for optimal air distribution. A damper, adjustable from underneath, used for air volume control, can be installed (even when already installed) for both supply and return air versions at an extra charge. For plenum boxes type SK-R-..., the ceiling diffuser must be removed, before the damper can be adjusted. Alternatively, a cable-operated adjustment can be ordered at an extra charge, which allows the damper to be adjusted on the room side even with mounted diffuser.

The ceiling diffuser is fitted to the plenum box with a central screw for a masked assembly (concealed mounting). The funnel shaped VM holder on the traverse makes assembly of the ceiling diffuser much easier. A volumetric flow meter can be integrated in the connection spigot of the plenum box at an extra charge. The measurement error of the volumetric flow meter is  $\pm 5\%$  at a connection spigot velocity of 2-5 m/s and a straight flow pattern of at least  $1 \times D$ . The measurement is carried out with dismantled diffuser. By adjusting the throttle damper, the required air volume of each diffuser can be set quickly and correctly.

With the ROB model of the SK-Q-... plenum box the diffuser plate, damper and volumetric flow meter can be removed to allow duct cleaning robots into the ductwork from room side.

For square and round supply air models with SM mounting or for installation in grid ceilings, the ceiling impulse diffuser is

connected to ductwork via a reduction piece type RF.

The ceiling impulse diffuser has been tested successfully by TÜV SÜD in accordance with the following regulations:

- VDI 6022 Sheet 1: Hygienic requirements of ventilation and air-conditioning systems
- VDI 6022 Sheet 2: Hygienic requirements of ventilation and air-conditioning systems - Measurement methods and investigations during hygienic controls and hygienic inspections
- DIN 1946 Sheet 2: Air-conditioning technology - Health requirements

### Minimum volumetric flow range $V_{min}$ ( $\Delta T = -12 K$ )

NW	$V_{min}$			
	PIL-N-...		PIL-G-...	
	(m <sup>3</sup> /h)	(l/s)	(m <sup>3</sup> /h)	(l/s)
310	80	22	-	-
400	100	28	150	42
500	150	42	200	56
600 / 625	300	83	350	97

### Attention!

**The correct functioning of the ceiling impulse diffuser type PIL-... is only guaranteed in connection with the plenum box type SK-... suitable for PIL- diffusers!**

### Comparison of PIL-G with PIL-N for NW 600/625

	PIL-N-...	PIL-G-...	Difference
$L_{WA}$ [dB(A)]	35	35	
$\Delta p_t$ (Pa)	26	18	-32%
$V_{ZU}$ (m <sup>3</sup> /h)	500	760	+52%

## Ceiling Impulse Diffuser Model PIL

### Square designs

PIL-...-QV-...

V drill pattern

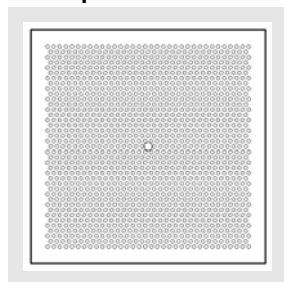

PIL-...-QS-...

S drill pattern

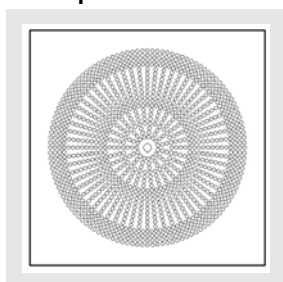

PIL-...-QK-...

K drill pattern

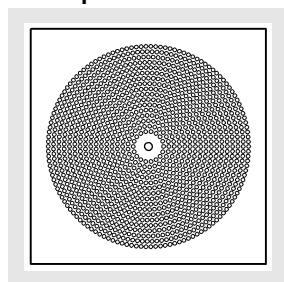

### Round designs

PIL-...-RV-...

V drill pattern

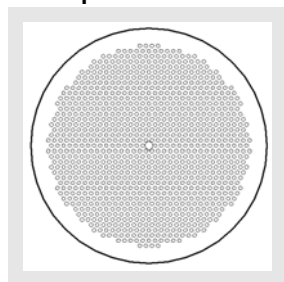

PIL-...-RS-...

S drill pattern

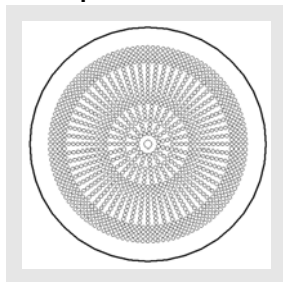

PIL-...-RK-...

K drill pattern

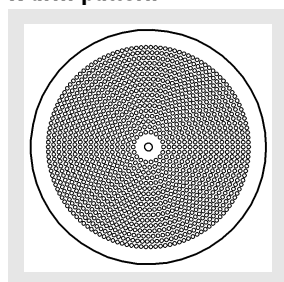

**Note:** Only the square model with V drill pattern is available in aluminium.

## Construction

Faceplate

- perforated sheet steel painted RAL 9010 (white)
- perforated natural colour anodised aluminium (available only for PIL-...-QV-... model)

baffle plate

- Sheet steel painted to RAL 9005 (black), only for supply air model

Funnel

- Sheet steel painted to RAL 9005 (black), only for supply air model

## Model

PIL-N-... - for standard air volumes, supply air and return air

PIL-G-... - for large air volumes, only for supply air

PIL-...-QV-... - square front plate, offset perforations

PIL-...-QS-... - square design, star-shaped perforations (not possible in aluminium)

PIL-...-QK-... - square design, circular perforation (not possible in aluminium)

PIL-...-RV-... - round front plate, displaced perforations

PIL-...-RS-... - round design, star-shaped perforations (not possible in aluminium)

PIL-...-RK-... - round design, circular perforation (not possible in aluminium)

PIL-...-Z-... Supply air

PIL-...-A-... Return air (not for PIL-G)

## Fastening

Concealed mounting (-VM)

- Traverse fixing, by means of M6 cylinder screw (to DIN EN ISO 4762) at the plenum box.

Screw mounting (-SM)

- only for models with ball-impact guard or in combination with a reduction piece
- with raised countersunk head tapping screws (on site)

## Ceiling Impulse Diffuser Model PIL

### Accessories

Plenum box SK-Q-... and SK-R-...)

- Galvanised sheet steel, with integrated perforated straightener (supply air model only) and fixing lugs.

Damper (-DK1)

- Damper fastening made of plastic
- Galvanised sheet steel

Damper (-DK2)

- DK1 with cable-operated adjustment

Rubber lip seal (-GD1)

- Special rubber

Volumetric flow meter (-VME1)

- Aluminium connections
- Measuring sensor made of plastic
- holder made of galvanised sheet steel

ROB version (-ROB1)

- only possible for SK-Q-... plenum box
- Removable diffuser plate, damper and volumetric flow meter

Ball-impact guard (-BS)

- only possible for PIL-...-Q...-... with SM mounting.
- Steel painted to RAL 9010 (white), other RAL colours possible at an extra charge.

Internal insulation (-li)

- thermal insulation at the inside of the plenum box

External insulation (-la)

- thermal insulation at the outside of the plenum box

Reduction piece (-RF)

- Galvanised sheet steel
- for connection to ducts without plenum box
- for supply air models with SM mounting only or for installation in grid ceilings (not possible for PIL-G-...)

# Ceiling Impulse Diffuser Model PIL

## Models and dimensions

### Dimensions

PIL-...-Q...-Z... with SK-Q...-Z... (for supply air)

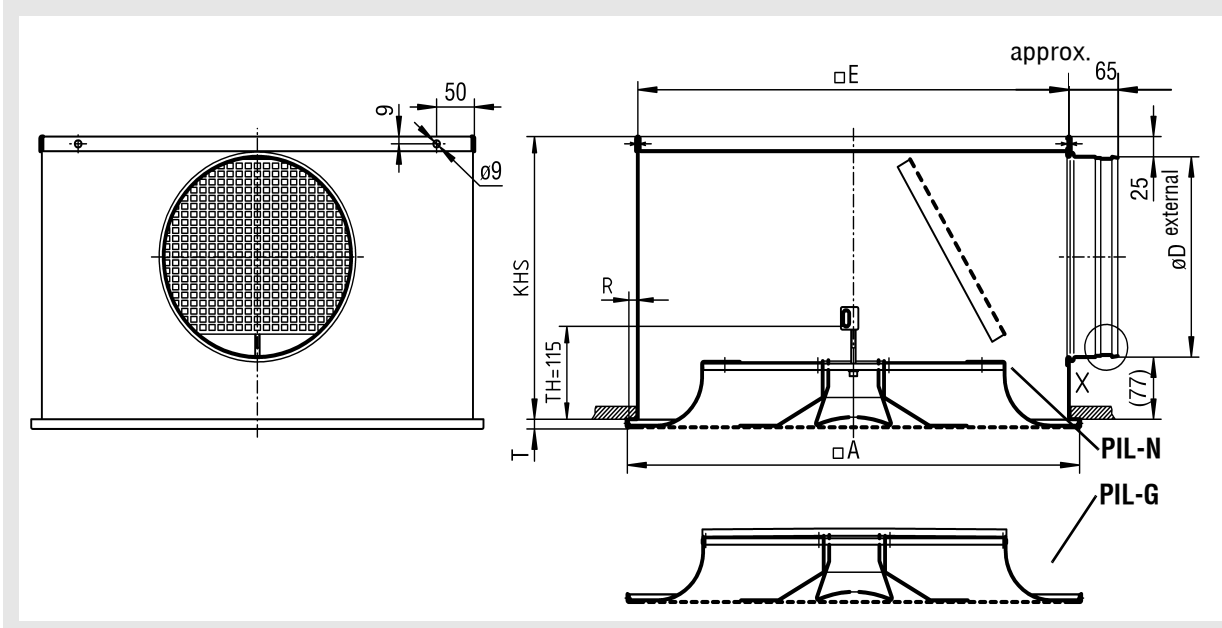

PIL-N-Q...-A... with SK-Q...-A... (for return air)

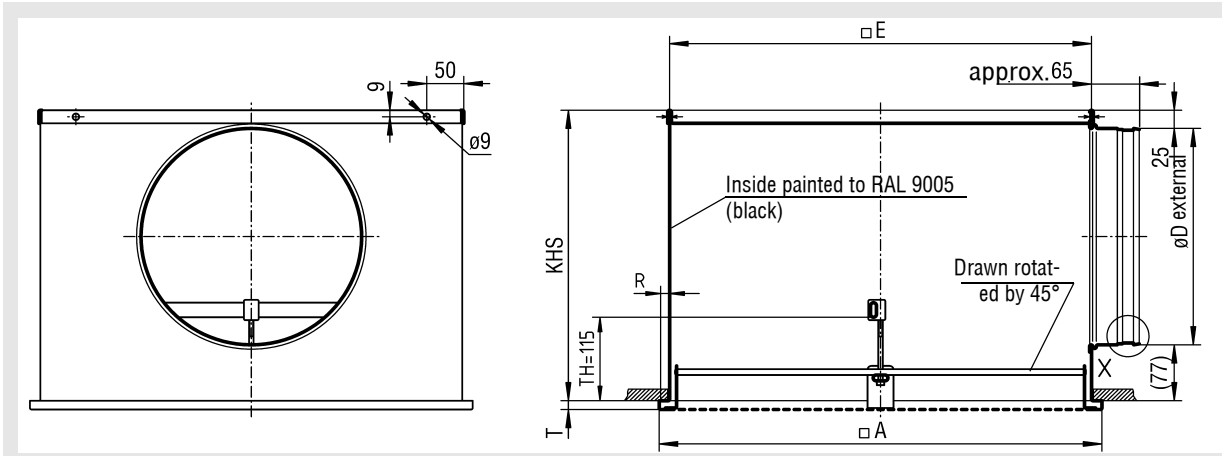

### Available sizes

NW	□A	□E	T	R	PIL-N-Q...-Z		PIL-G-Q...-Z		PIL-N-Q...-A		øD <sub>max</sub> for ...-S5
					KHS	øD	KHS	øD	KHS	øD	
310	308	290	12	8	260	158	-	-	300	198	98
400	398	370		12	260	158	300	198	300	198	138
500	498	470		12	300	198	350	248	350	248	198
600	598	570		12	350	248	415	313	400	298	248
625	623	570		24	350	248	415	313	400	298	248

### Spigot position

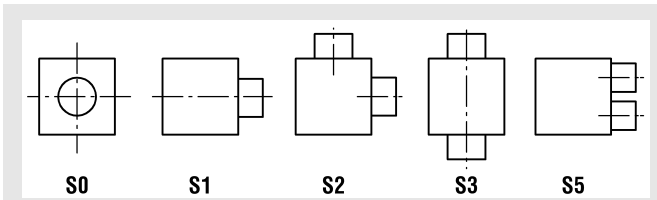

KHS= standard height of plenum box  
Special height of plenum box = øD + 102mm, but at least 200mm

## Ceiling Impulse Diffuser Model PIL

PIL-...-R...-Z... with SK-R...-Z... (for supply air)

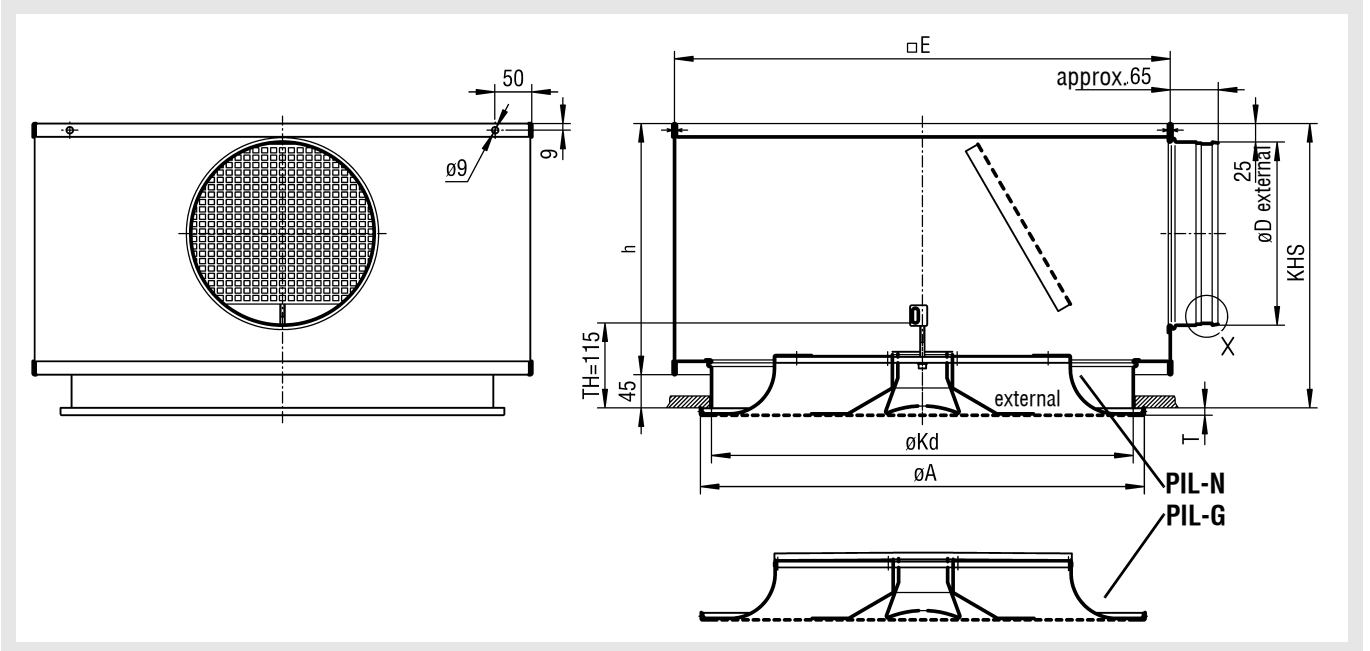

PIL-N-R...-A... with SK-R...-A... (for return air)

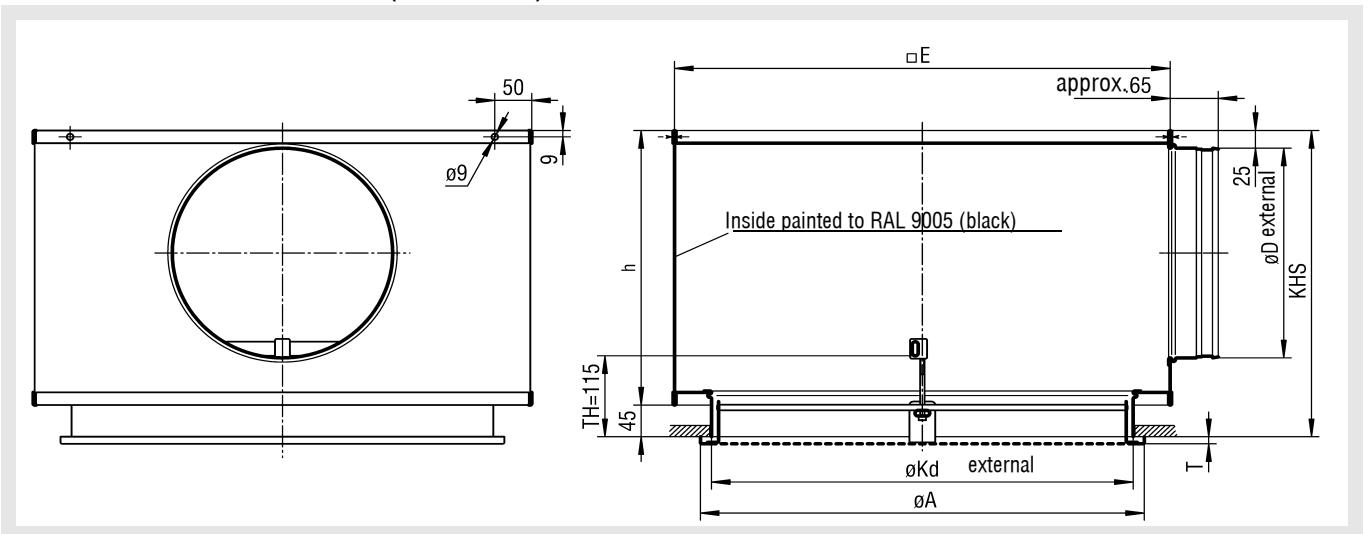

### Available sizes

NW	øA	øKd	□E	T	PIL-N-R...-Z			PIL-G-R...-Z			PIL-N-R...-A			øD <sub>max</sub> for ...-S5
					KHS	øD	h	KHS	øD	h	KHS	øD	h	
310	310	298	405	10	295	158	250	-	-	-	335	198	290	158
400	400	370	445		295	158	250	335	198	290	335	198	290	178
500	500	470	545		335	198	290	385	248	340	385	248	340	198
600	600	570	670		385	248	340	450	313	405	435	298	390	298
625	625	570	670		385	248	340	450	313	405	435	298	390	298

### Spigot position

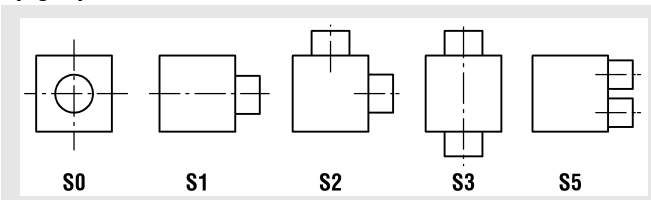

KHS= standard height of plenum box  
Special height of plenum box = øD + 137 mm, but at least 235 mm

## Ceiling Impulse Diffuser Model PIL

### Accessories - dimensions

(at an extra charge)

#### Damper (-DK1)

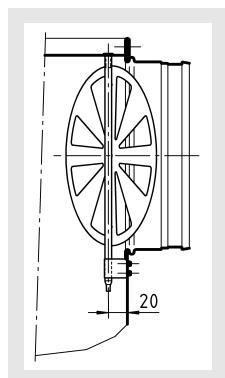

#### Damper (-DK2) with cable-operated adjustment

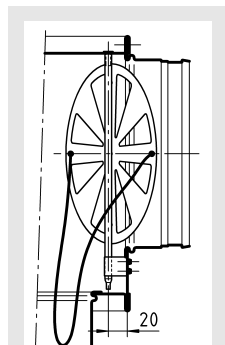

#### Rubber lip seal (-GD1)

Detail X

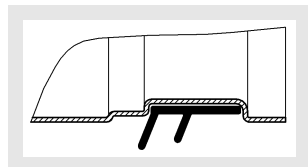

#### Volumetric flow meter (-VME1)

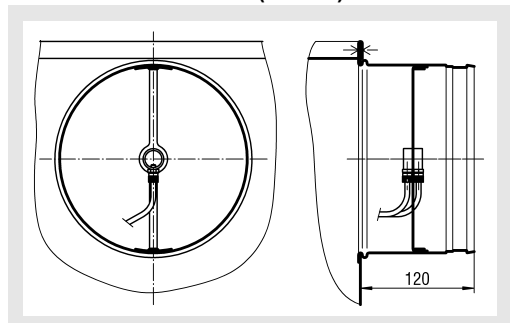

#### Insulation for SK-Q-...

internal (-li)

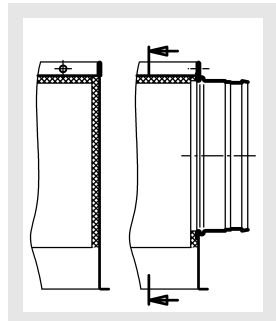

external (-la)

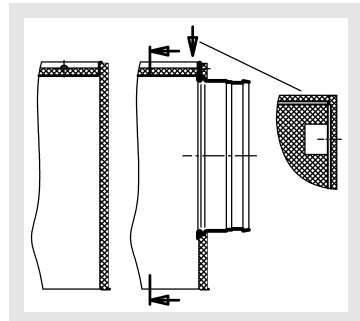

#### Insulation for SK-R-...

internal (-li)

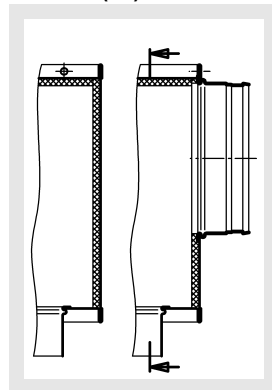

external (-la)

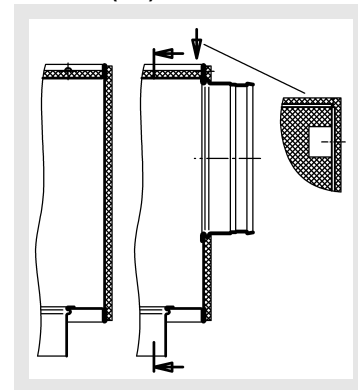

#### Reduction piece for connection ductwork (-RF)

(not possible for PIL-G-...)

For supply air model with screwed mounting only or for installation in grid ceilings

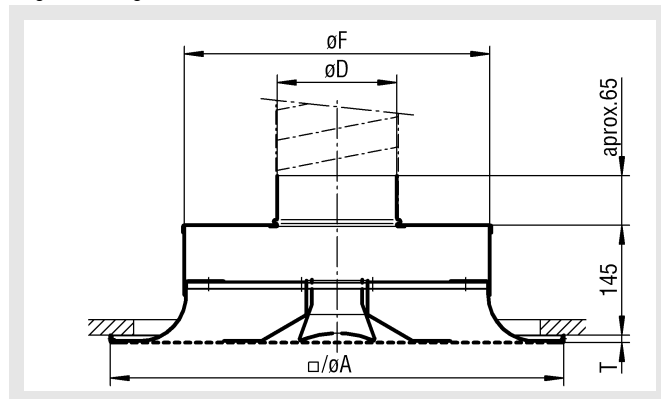

The technical data and the function are the same as those of the supply air models with plenum box and damper (100% open).

#### Available sizes

NW	$\square A$ PIL-N- Q...-...	$\varnothing A$ PIL-N- R...-...	$\varnothing F$	T PIL-N- Q...-...	T PIL-N- R...-...	$\varnothing D$
310	308	310	126	12	10	98
400	398	400	254			158
500	498	500	319			198
600	598	600	404			248
625	623	625	404			248



# Ceiling Impulse Diffuser Model PIL

## Ball-impact guard (-BS)

(only possible for PIL-...-Q...-... with SM mounting)

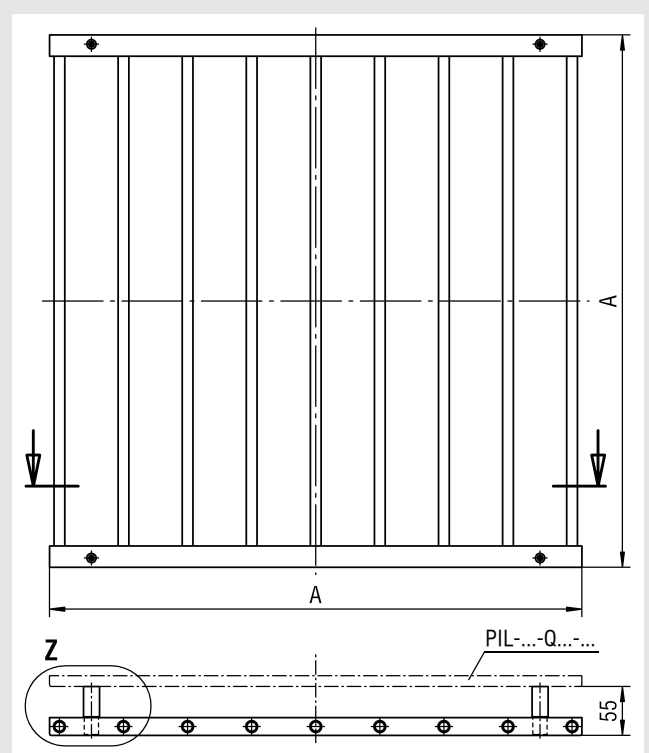

### Detail Z

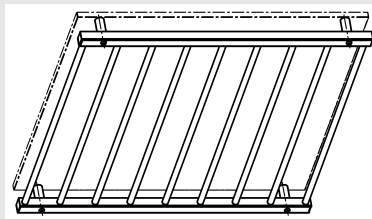
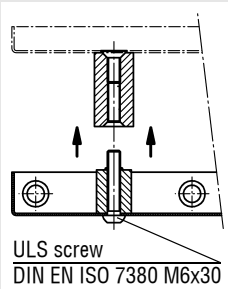

### Available sizes

NW	□ A
310	308
400	398
500	498
600	598
625	623

## Fastening methods

### Screw mounting (-SM) (only PIL-...-Q...-...)

only for models with ball-impact guard or in combination with a Reduction piece

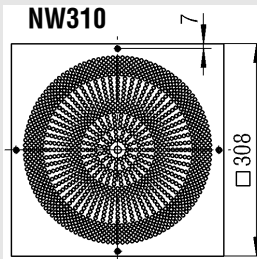

with indentation for slotted shallow-raised countersunk-head tapping screw (on-site)

- NW 310:  
DIN ISO 7051 pitch 3.9
- NW 400-625:  
DIN ISO 7051 pitch 4.8

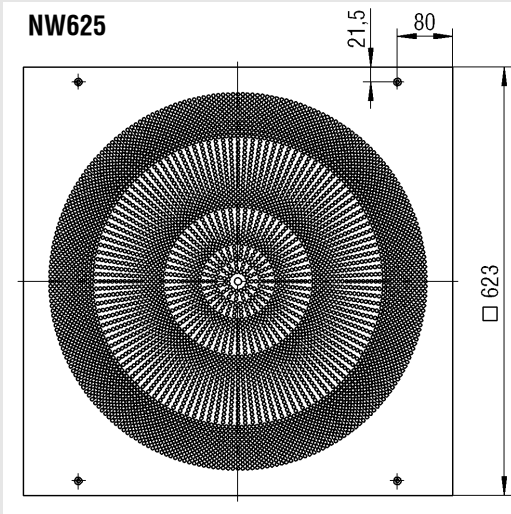
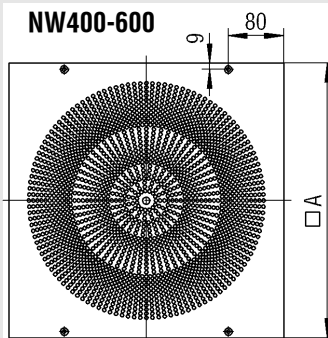

### Concealed mounting (-VM)

In concealed mounting, the ceiling impulse diffuser type PIL-... is fixed to the plenum box by means of a pole brace and an M6 cylinder head screw (to DIN EN ISO 4762).

**Attention: The max. torque of the fastening screw is 0.4 Nm**

## Ceiling Impulse Diffuser Model PIL

### Technical data of PIL-N-...

#### Pressure loss and noise level

##### PIL-N-...-Z-310-...

Supply air model square / round

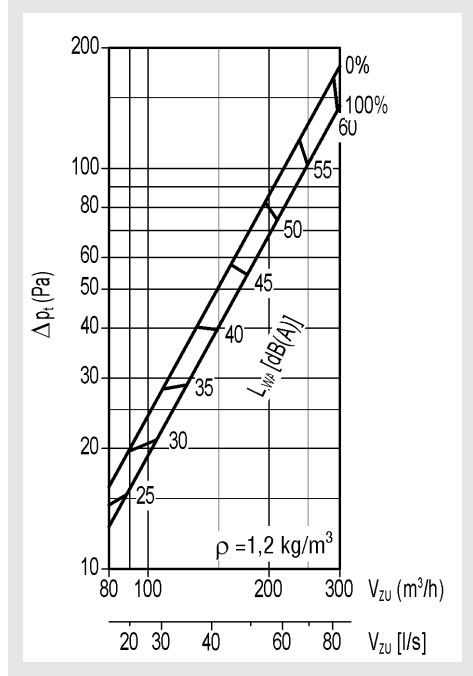

##### PIL-N-...-Z-400-...

Supply air model square / round

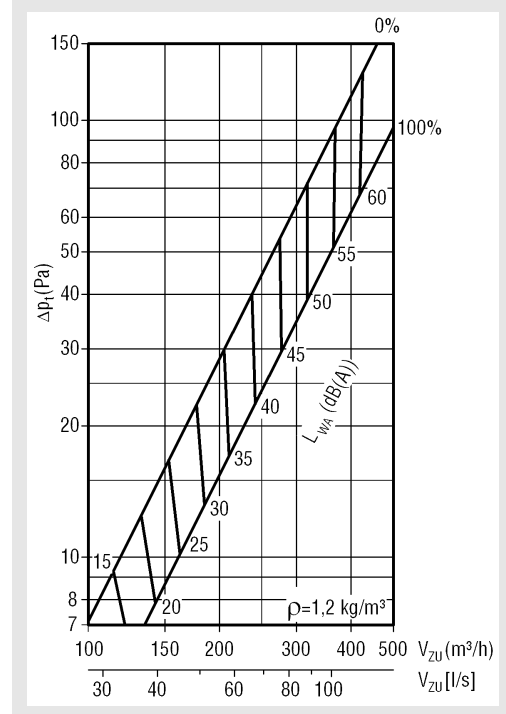

##### PIL-N-...-Z-500-...

Supply air model square / round

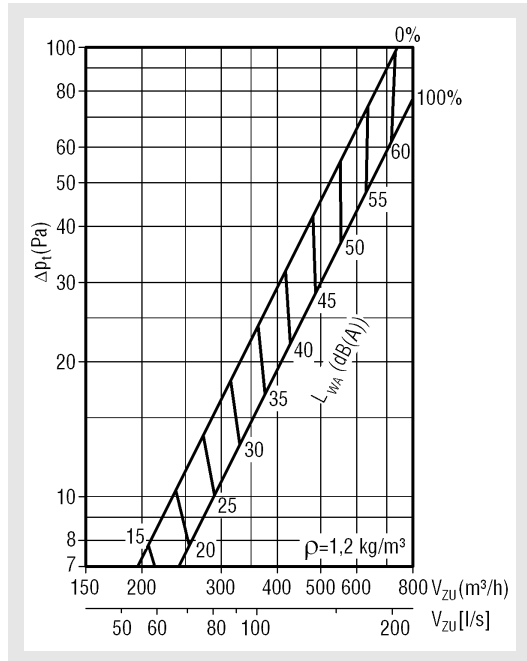

##### PIL-N-...-Z-600/625-...

Supply air model square / round

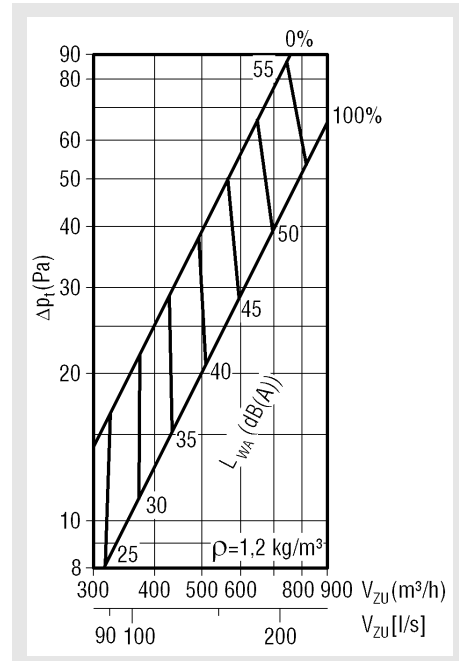

(Supply air) with plenum box, pole brace and damper

Damper position:

OPEN = 100%

CLOSED = 0%

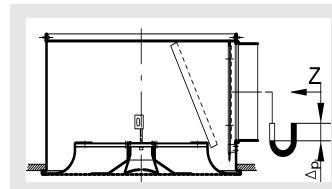

## Ceiling Impulse Diffuser Model PIL

PIL-N-...-A-310-...

Return air model square / round

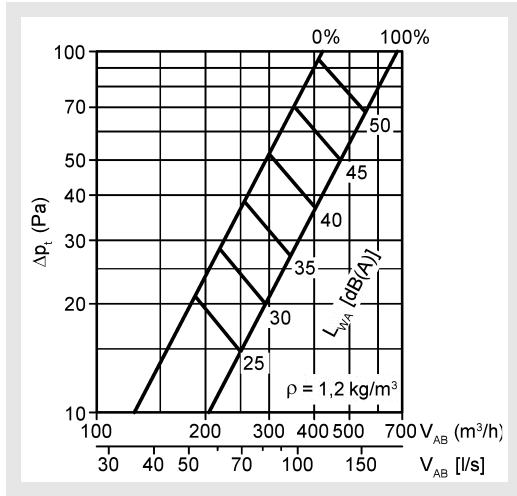

PIL-N-...-A-400-...

Return air model square / round

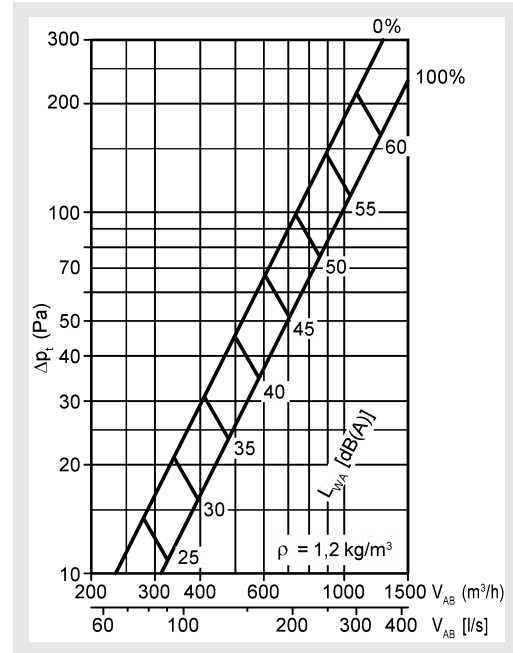

PIL-N-...-A-500-...

Return air model square / round

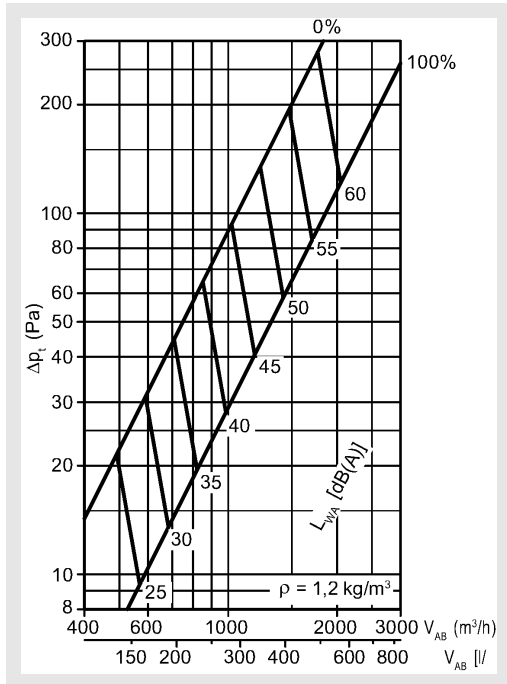

PIL-N-...-A-600/625-...

Return air model square / round

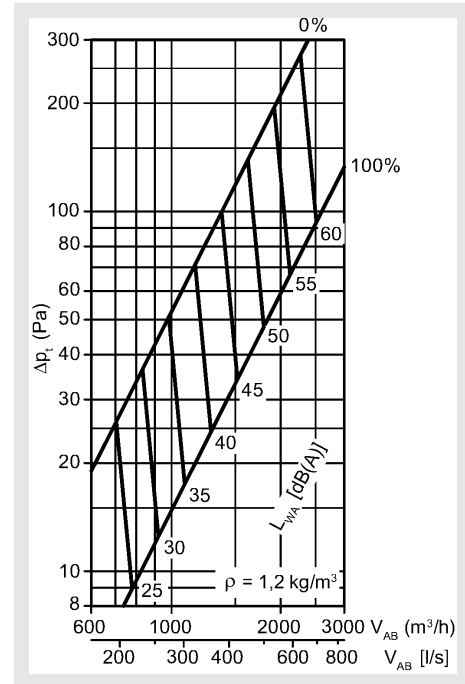

(return air) with plenum box, traverse and damper

Damper position:

OPEN = 100%

CLOSED = 0%

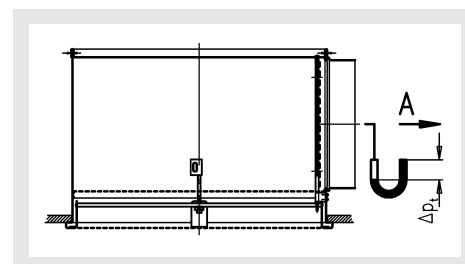

# Ceiling Impulse Diffuser Model PIL

## Maximum end velocity of jet

PIL-N-...-Z-310-...

Supply air model square / round

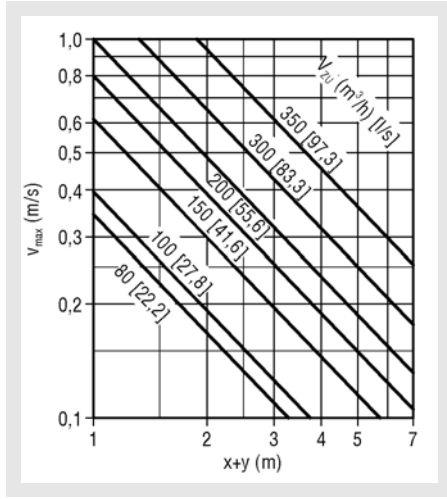

PIL-N-...-Z-400-...

Supply air model square / round

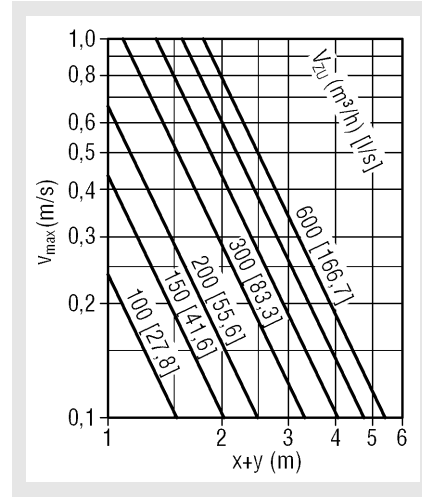

PIL-N-...-Z-500-...

Supply air model square / round

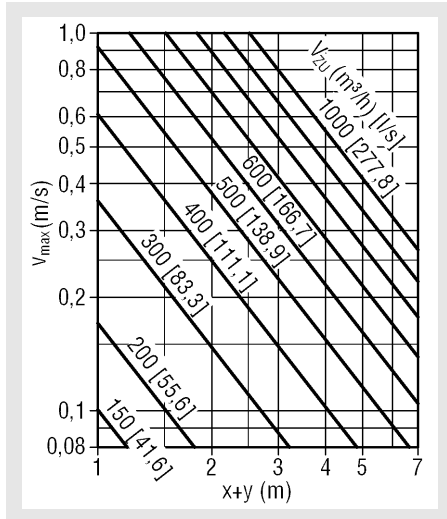

PIL-N-...-Z-600/625-...

Supply air model square / round

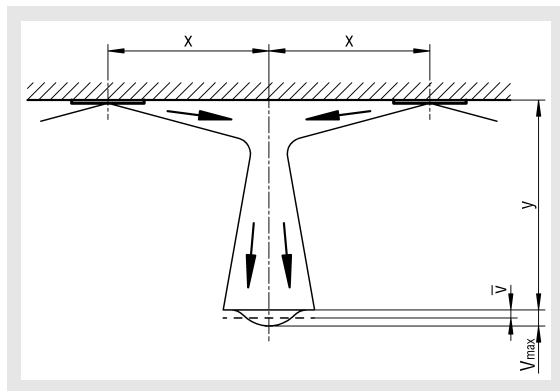
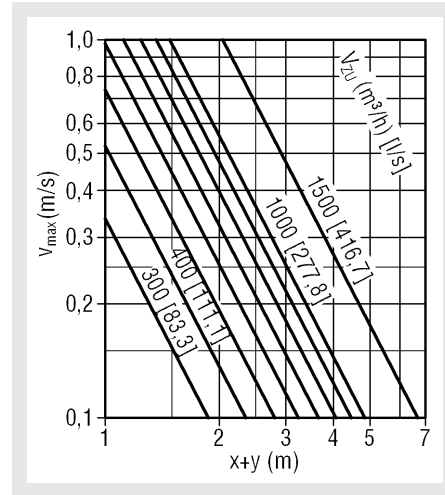

isothermal, with coanda effect / with plenum box

# Ceiling Impulse Diffuser Model PIL

## Critical throw

PIL-N-...-Z-310-...

Supply air model square / round

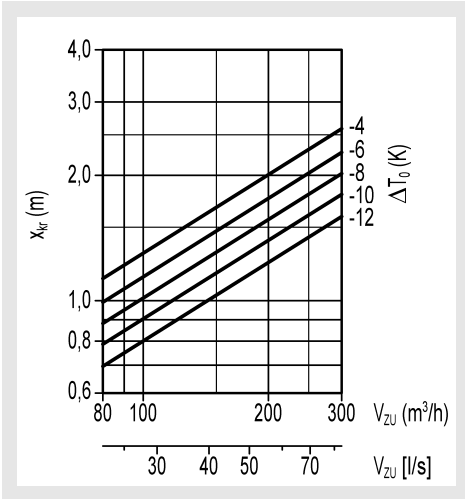

PIL-N-...-Z-400-...

Supply air model square / round

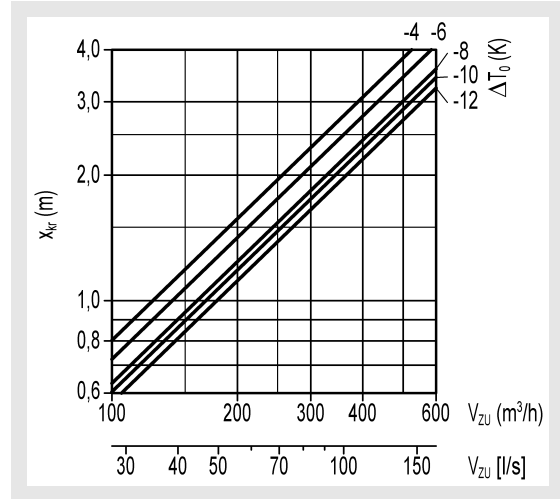

PIL-N-...-Z-500-...

Supply air model square / round

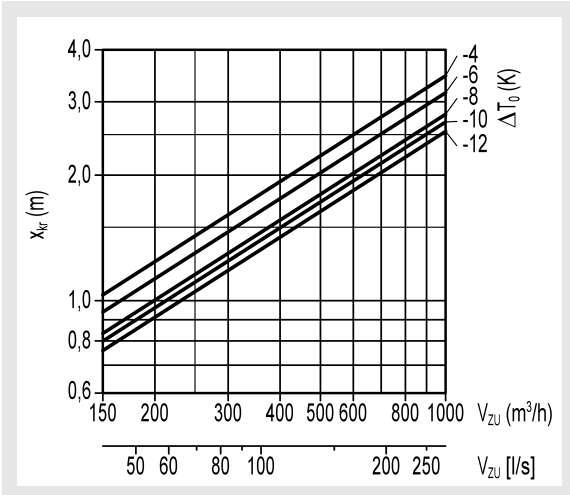

PIL-N-...-Z-600/625-...

Supply air model square / round

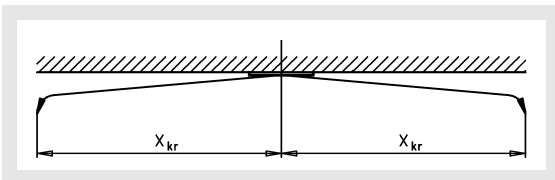
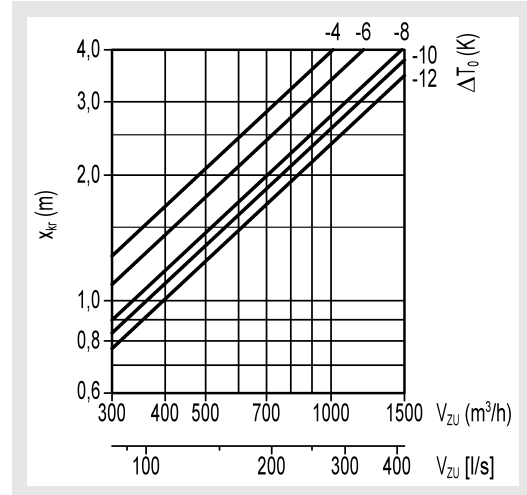

## Ceiling Impulse Diffuser Model PIL

### PIL-N-...-Z-... induction ratio

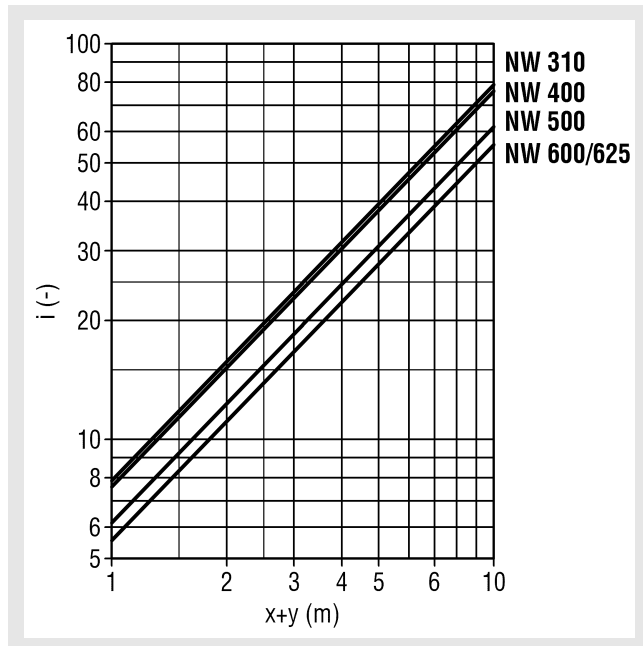

### PIL-N-...-Z-... temperature ratio

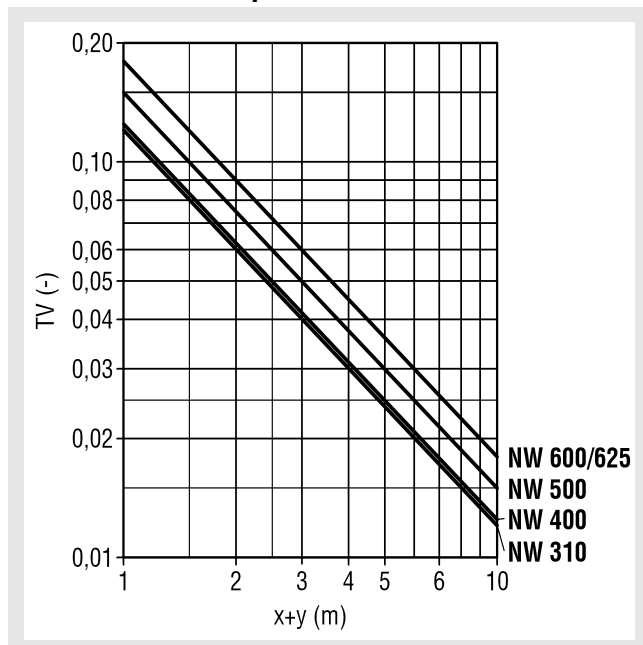

# Ceiling Impulse Diffuser Model PIL

## Technical data of PIL-G-...

### Pressure loss and noise level

#### PIL-G-...-Z-400-...

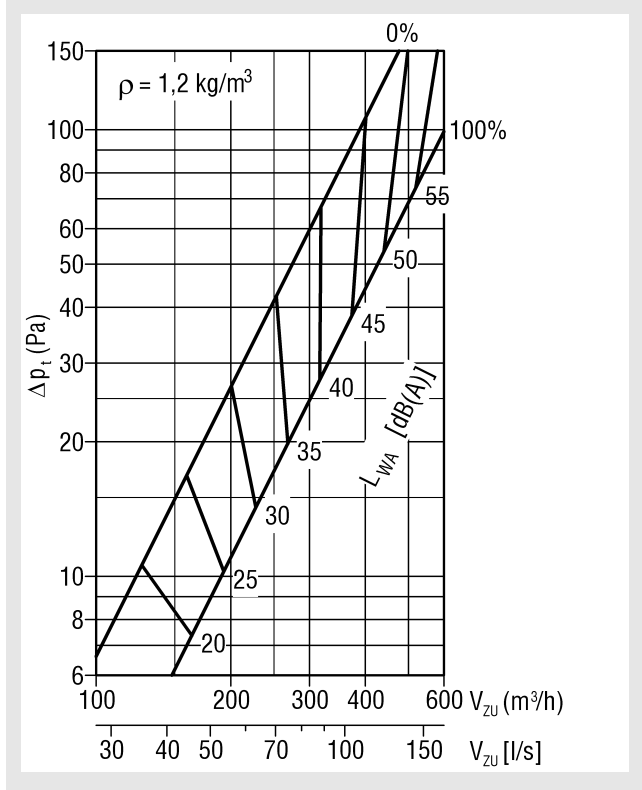

#### PIL-G-...-Z-500-...

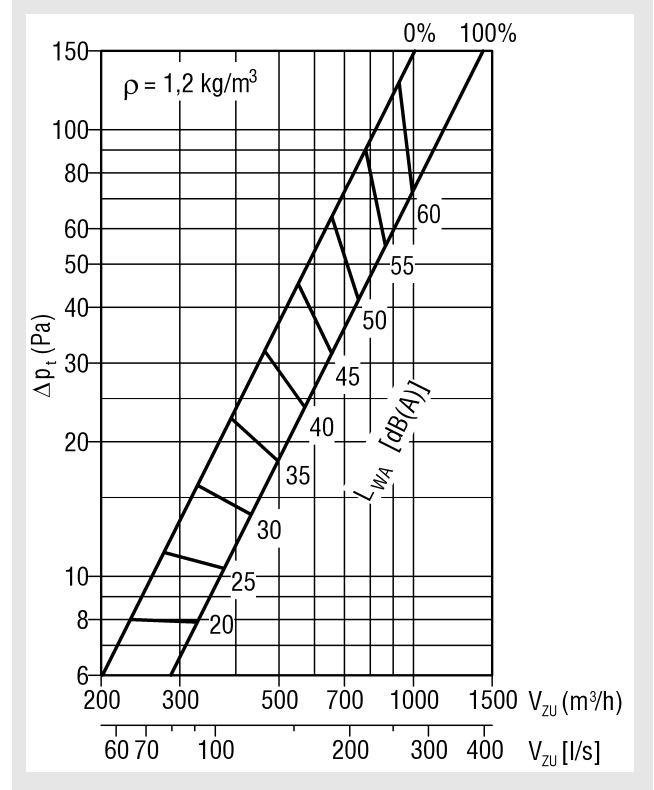

#### PIL-G-...-Z-600-...

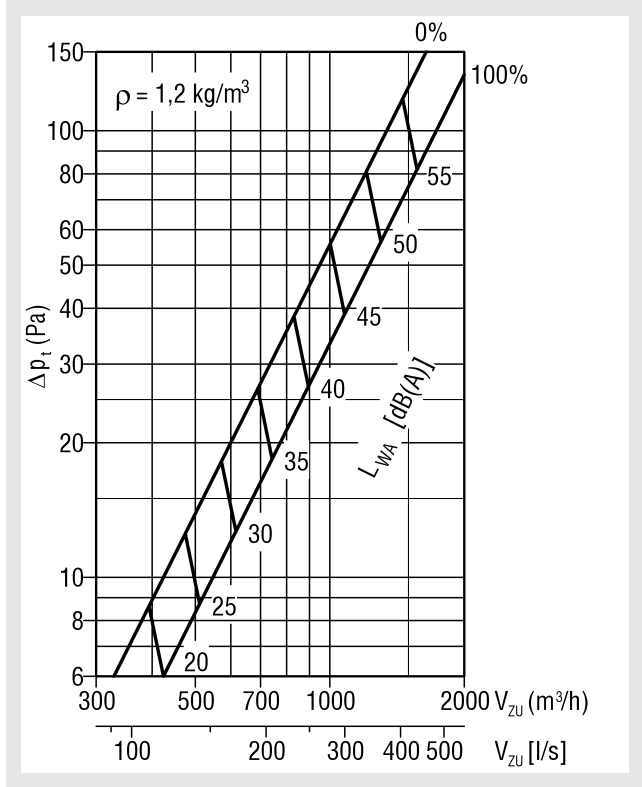

(Supply air) with plenum box, pole brace and damper

Damper position:

OPEN = 100%

CLOSED = 0%

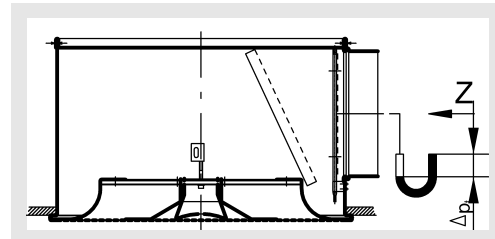

**Note:** The sound and pressure loss data always apply to the standard plenum boxes.

## Ceiling Impulse Diffuser Model PIL

### Maximum end velocity of jet

PIL-G-...-Z-400-...

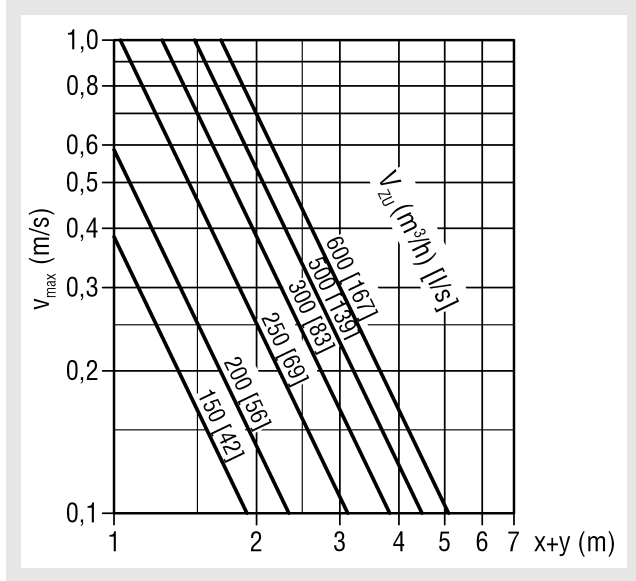

isothermal, with coanda effect / with plenum box

PIL-G-...-Z-500-...

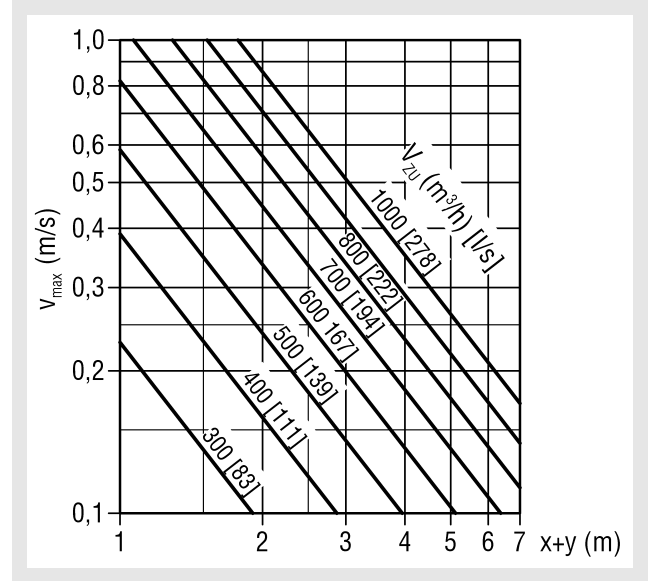

PIL-G-...-Z-600-...

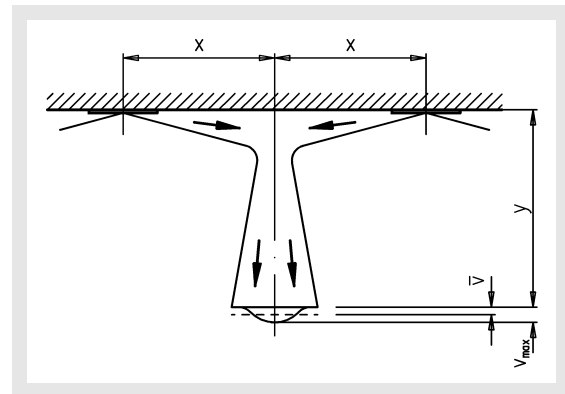
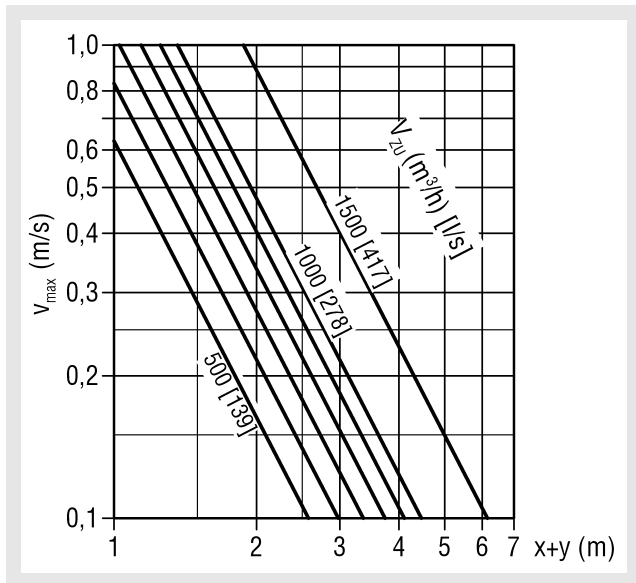



# Ceiling Impulse Diffuser Model PIL

## Critical throw

PIL-G-...-Z-400-...

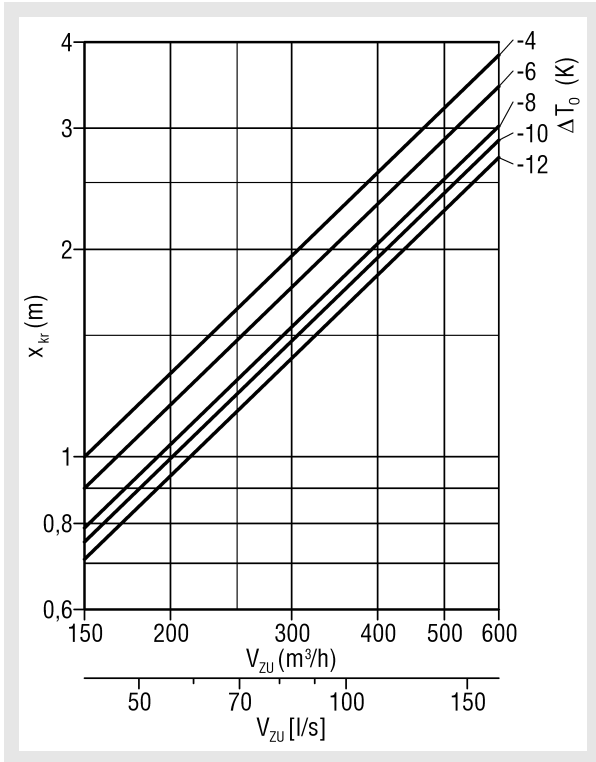

PIL-G-...-Z-500-...

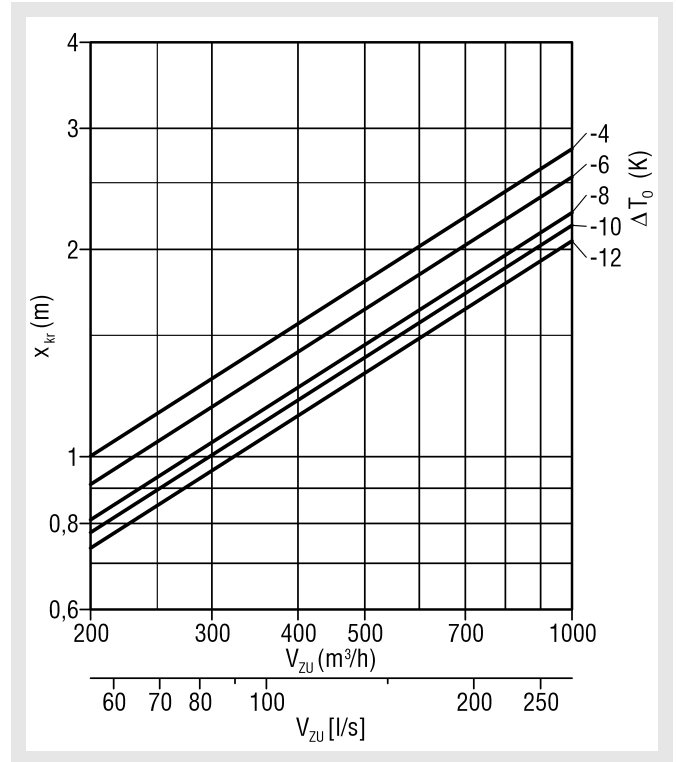

PIL-G-...-Z-600-...

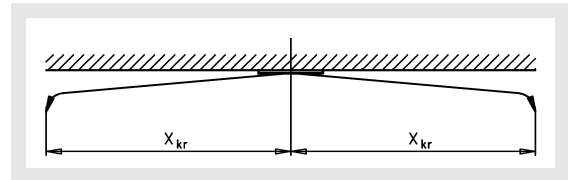
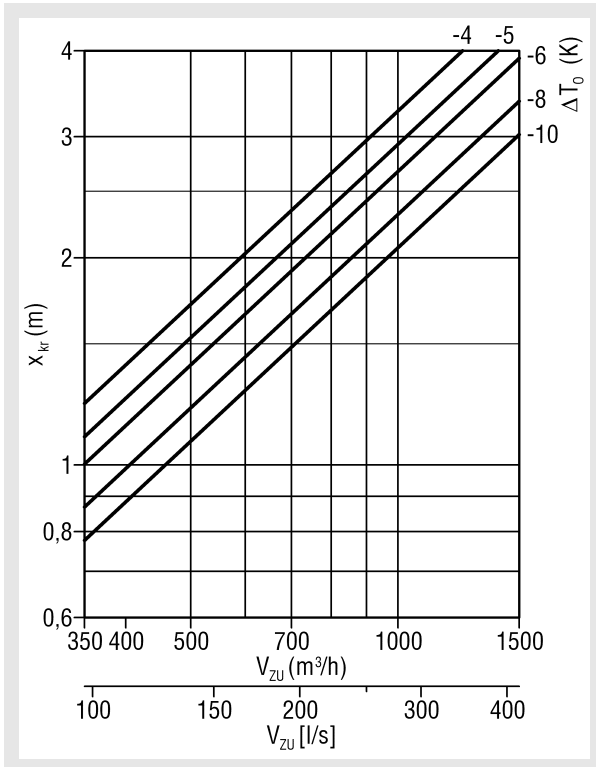

## Ceiling Impulse Diffuser Model PIL

### PIL-G-...-Z-... induction ratio

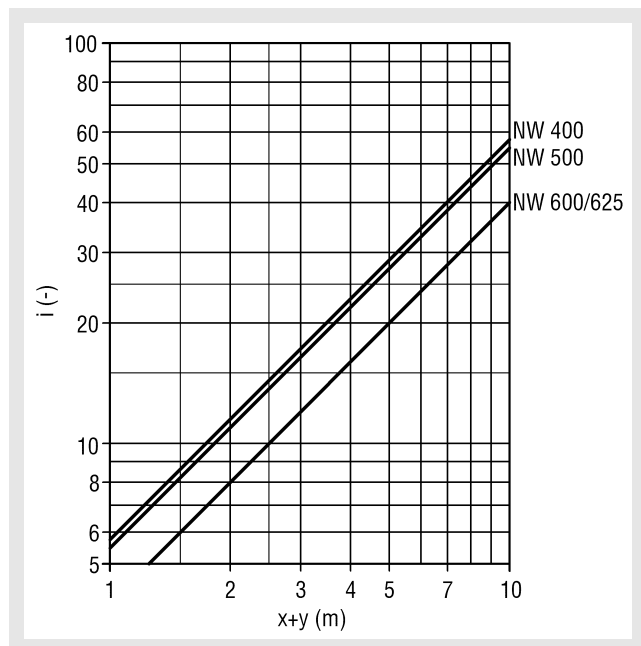

### Legend

$V_{ZU}$	(m <sup>3</sup> /h) [l/s]	= Supply air volume
$V_{AB}$	(m <sup>3</sup> /h) [l/s]	= Return air volume
$V_x$	(m <sup>3</sup> /h) [l/s]	= total air jet volume at point x
$\Delta p_t$	(Pa)	= Pressure loss
$L_{WA}$	[dB(A)]	= A-weighted sound power level
$\rho$	(kg/m <sup>3</sup> )	= Density
A		= Return air
Z		= Supply air
x	(m)	= horizontal throw
y	(m)	= vertical throw
x+y	(m)	= Horizontal + vertical throw
$v_{max}$	(m/s)	= Maximum end velocity of jet
$v_{mittel}$	(m)	= Average end velocity of jet ( $v_{mittel} = v_{max} \times 0.5$ )
$x_{kr}$	(m)	= Critical throw
$\Delta T_0$	(K)	= Temperature difference between supply air temperature and room temperature ( $\Delta T_0 = t_{ZU} - t_R$ )
$\Delta T_x$	(K)	= Temperature difference at point x
$t_{ZU}$	(°C)	= Supply air temperature
$t_R$	(°C)	= Room temperature
TV	(-)	= Temperature ratio (TV = $\Delta T_x / \Delta T_0$ )
i	(-)	= Induction ratio ( $i = V_x / V_{ZU}$ )
NW	(mm)	= Nominal width

### PIL-G-...-Z-... temperature ratio

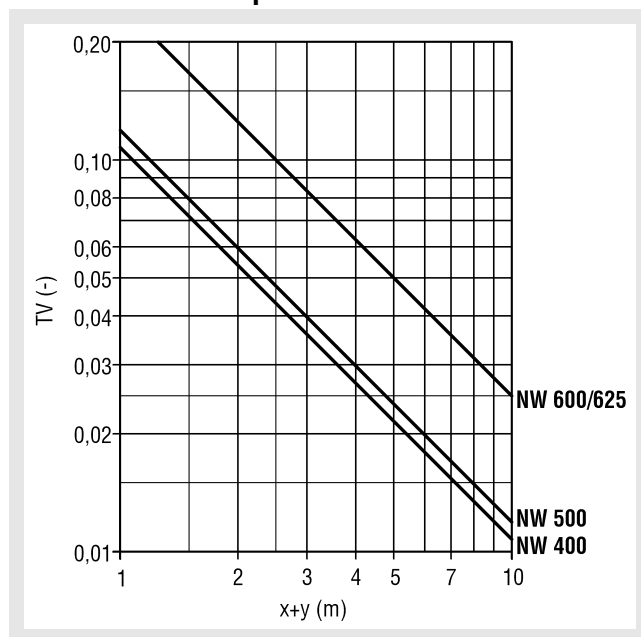

## Ceiling Impulse Diffuser Model PIL

### Order code PIL

01	02	03	04	05	06	07	08	09	10	11
Type	Air volume	Model	Air throw	Nominal size	Material	Paint	Drill pattern reduced	Mounting	Ball-impact guard	Reduction piece
<b>Example</b>										
PIL	-N	-QV	-Z	-500	-SB	-9010	-000	-VM	-B0	-R0

#### Sample

#### **PIL-N-QV-Z-500-SB-9010-000-VM-B0-R0**

Ceiling impulse diffuser type PIL | for standard air volume | square faceplate, drill pattern V (standard) | supply air | NW500 | faceplate made of sheet steel | RAL 9010 white | drill pattern not reduced | concealed mounting | without ball-impact guard | without reduction piece

#### Order details

##### 01 - Type

PIL = Ceiling impulse diffuser

##### 02 - Air volume

N = Normal

G = Large

##### 03 - Model

QV = Square faceplate, drill pattern V (standard)

QS = Square faceplate, drill pattern S

QK = Square faceplate, drill pattern K

RV = round faceplate, drill pattern V

RS = round faceplate, drill pattern V S

RK = round faceplate, drill pattern K

Only -QV model is available in aluminium.

##### 04 - Air throw

Z = Supply air

A = Return air (not possible for PIL-G-...)

##### 05 - Nominal size

310 = NW 310 (not possible for PIL-G-...)

400 = NW 400

500 = NW 500

600 = NW 600

625 = NW 625

##### 06 - Material

SB = Sheet steel (standard)

AL = Aluminium (natural colour anodised) (for PIL-...-QV-... only)

##### 07 - Paint

9010 = RAL colour white (standard)

xxxx = RAL colour can be freely selected

ELOX = natural colour anodised (only possible for aluminium)

The RAL colours are also possible for aluminium.

##### 08 - Drill pattern reduced

000 = Drill pattern not reduced (standard)

310 = reduced drill pattern 310 (not possible for PIL-G-...)

400 = reduced drill pattern 400

500 = reduced drill pattern 500

The drill pattern selected must be smaller than the nominal size selected.

##### 09 - Mounting

VM = Concealed mounting (standard)

SM = Screw mounting (only in combination with ball-impact guard or reduction piece)

##### 10 - Ball-impact guard

B0 = without ball-impact guard (standard)

BS = with ball-impact guard painted to the same colour as the faceplate (for square model only)

##### 11 - Reduction piece

R0 = without reduction piece (standard)

RF = with reduction piece for connection to ductwork (for supply air model with SM mounting only or for installation in grid ceilings, not possible for PIL-G-...).

## Ceiling Impulse Diffuser Model PIL

### Order code SK

01	02	03	04	05	06	07
Plenum box	Model	Air diffuser	Type of air	Nominal size	Fastening	Material
<b>Example</b>						
SK	-Q	-03	-Z	-500	-VM	-SV

08	09	10	11	12	13	14	15
Damper	Rubber lip seal	Volumetric flow meter	ROB Model	Insulation	Height of plenum box	Spigot diameter	Spigot position
-DK1	-GD1	-VME1	-ROB0	-I0	-KHS	-SDS	-S1

### Sample

**SK-Q-03-Z-500-VM-SV-DK1-GD1-VME1-ROB0-I0-KHS-SDS-S1**

Plenum box, square design I for square air diffusers I air diffuser PIL-G I supply air I NW500 I with concealed mounting I galvanised sheet steel I with damper I with rubber lip seal I with volumetric flow meter I without ROB model I without box insulation I standard height of plenum box I standard spigot diameter I 1 lateral spigot

### Order details

#### 01 - Plenum box

SK = Plenum box, square design

#### 02 - Model

Q = for square air diffusers

R = for round air diffusers with round diffuser support

#### 03 - Air diffuser (must be ordered separately)

02 = suitable for PIL-N-... (for standard air volumes)

03 = suitable for PIL-G-... (for large air volumes)

#### 04 - Type of air

Z = Supply air

A = Return air (not possible for PIL-G-...)

#### 05 - Nominal size

310 = NW 310 (not possible for PIL-G-...)

400 = NW400

500 = NW500

600 = NW600

625 = NW625

#### 06 - Fastening

VM = Concealed mounting (standard)

SM = Screw mounting (only for the model with ball-impact guard)

#### 07 - Material

SV = Galvanised sheet steel (standard)

#### 08 - Damper

DK0 = Without damper (standard)

DK1 = With damper

DK2 = with damper + cable

#### 09 - Rubber lip seal

GD0 = Without rubber lip seal (standard)

GD1 = With rubber lip seal

#### 10 - Volumetric flow meter

VME0 = Without volumetric flow meter (standard)

VME1 = With volumetric flow meter

#### 11 - ROB model

ROB0 = Without ROB version (standard)

ROB1 = With ROB version (not possible for SK-R-...)

#### 12 - Insulation

I0 = Without insulation (standard)

Ii = With box insulation inside

Ia = With box insulation outside

## Ceiling Impulse Diffuser Model PIL

### 13 - Height of plenum box

KHS = Height of plenum box standard

xxx = Height of plenum box in mm (Height<sub>min</sub> = spigot diameter + 102 mm for PIL-...-Q...-.../ spigot diameter + 137 mm for PIL-...-R...-..., but at least 235 mm)

### 14 - Spigot diameter

SDS = Spigot diameter standard

xxx = Spigot diameter in mm

### 15 - Spigot position

S0 = Spigot from above

S1 = 1 lateral spigot on the box (standard)

S2 = 2 spigots offset by 90°

S3 = 2 spigots offset by 180°

S5 = 2 spigots arranged next to each other

## Ceiling Impulse Diffuser Model PIL

### Specification texts

Square ceiling impulse diffuser for installation in supply and exhaust air systems in clean rooms, operating theatres and comfort rooms up to a height of 4 m.

Consisting of an easy to clean square perforated sheet steel front plate displaced with punch outs, painted RAL 9010 (white) or anodised aluminium in natural colour (natural colour anodised aluminium not available in the S model). The supply air model is additionally provided with a baffle plate and a sheet steel air guide funnel painted to RAL 9005 (black). It is fastened by concealed mounting (-VM) using a central fastening screw. TÜV inspected according to **VDI 6022 Sheets 1+2**, as well as **DIN 1946 Sheet 2**

Product: SCHAKO **type PIL-N-QV-Z-...**

- for large air volumes: product: SCHAKO **type PIL-G-QV-Z-...**

- star-shaped perforations (not possible in aluminium)

Product: SCHAKO **type PIL-N-QS-Z-...**

- for large air volumes

Product: SCHAKO **type PIL-G-QS-Z-...**

- Circular perforation (not possible in aluminium)

Product: SCHAKO **type PIL-N-QK-Z-...**

- for large air volumes

Product: SCHAKO **type PIL-G-QK-Z-...**

- Return air version without baffle plate and without air guide funnel Offset perforations

Product: SCHAKO **type PIL-N-QV-A-...**

- Return air version without baffle plate and without air guide funnel star-shaped perforations (not possible in aluminium)

Product: SCHAKO **type PIL-N-QS-A-...**

- Return air version without baffle plate and without air guide funnel Circular perforation (not possible in aluminium)

Product: SCHAKO **type PIL-N-QK-A-...**

- with screw mounting (-SM), only for models with ball-impact guard (-BS) or in combination with a reduction piece (-RF)

Round ceiling impulse diffuser for supply and return air systems in clean rooms, operating theatres and comfort rooms up to a height of 4 m.

Consisting of a round front plate easy to clean, with offset perforation, made of perforated sheet steel painted to RAL 9010 (white). The supply air model is additionally provided with a baffle plate and a sheet steel air guide funnel painted to RAL 9005 (black). It is fastened by concealed mounting (-VM) using a central fastening screw. TÜV inspected according to **VDI 6022 Sheets 1+2**, as well as **DIN 1946 Sheet 2**.

Product: SCHAKO **type PIL-N-R...-Z-...**

- for large air volumes: product: SCHAKO **type PIL-G-QV-Z-...**

- Star-shaped perforations. (not possible in aluminium)

Product: SCHAKO **type PIL-N-RS-Z-...**

- for large air volumes

Product: SCHAKO **type PIL-G-RS-Z-...**

- Circular perforation. (not possible in aluminium)

Product: SCHAKO **type PIL-N-RK-Z-...**

- for large air volumes

Product: SCHAKO **type PIL-G-RK-Z-...**

- Return air version without baffle plate and without air guide funnel Offset perforations.

Product: SCHAKO **type PIL-N-RV-A-...**

- Return air version without baffle plate and without air guide funnel Star-shaped perforations. (not possible in aluminium)

Product: SCHAKO **type PIL-N-RS-A-...**

- Return air version without baffle plate and without air guide funnel Circular perforation. (not possible in aluminium)

Product: SCHAKO **type PIL-N-RK-A-...**

## Ceiling Impulse Diffuser Model PIL

### Accessories:

- Plenum box (SK-Q-... and SK-R-...) made of galvanised sheet steel, with fixing lugs.
  - Supply air model with integrated perforated straightener.
  - Return air model inside painted to RAL 9005 (black)
  - with damper (-DK1) in plenum box, adjustable from below, for simple air volume regulation without dismantling the faceplate.
  - adjustable from below with cable (-DK2)
  - with volumetric flow meter (-VME1).
  - with ROB model (-ROB1), removable diffuser plate, damper and volumetric flow meter (only SK-Q-...)
  - with rubber lip seal (-GD1), at the connection spigot made of special rubber.
  - with thermal insulation
    - internal (-li)
    - external (-la)
  - Height of plenum box can be freely selected, xxx in mm, minimum height = spigot diameter + 102 mm with SK-Q-... and spigot diameter +137 mm with SK-R-..., but at least 235 mm)
  - Spigot diameter can be freely selected, xxx in mm
  - Spigot position:
    - S0= spigot from above
    - S1= 1 lateral spigot on the box (standard)
    - S2= 2 spigots offset by 90°
    - S3= 2 spigots offset by 180°
    - S5 = 2 spigots arranged next to each other
- Reduction piece made of galvanised sheet steel in the connection to ductwork (-RF), only for supply air model without plenum box