

**IB-Q**  
Ventilation grille**Contents**

Function and use .....	2
Models .....	2
Mounting .....	2
Processing .....	2
Accessories .....	3
Dimensions .....	4
Dimensions of accessories .....	6
Mounting options .....	10
Technical data .....	11
Legend .....	18
Order code IB .....	19
Order code AK .....	20
Specification text .....	21

## FUNCTION AND USE

Ventilation grille type IB-Q... for supply and return air, for **installation in ducts and plenum boxes, with horizontal or vertical, pivoting, individually adjustable air deflection blades on the front side**. For air volume regulation with hit-and-miss damper made of electrolytically galvanised sheet steel.

Frame and blades made of electrolytically galvanised sheet steel

(-SV-0000) or made of sheet steel painted to RAL 9010 (white) (-SB-9010, standard) or painted to a RAL colour of your choice (-SB-xxxx).

As standard, screw mounting is used for fastening the ventilation grille. Concealed mounting (-VM) only possible in combination with an installation frame or a plenum box. Clamp mounting (-KB) is only possible without plenum box or installation frame.

At an extra charge, a plenum box (-AK-31) with or without inserted damper (for an easy air volume regulation) can be mounted.

## MODELS

IB-Q-...	for duct and plenum box installation.
IB-Q-01-...	horizontal pivoting air deflection blades on the front side.
IB-Q-02-...	same as IB-Q-01-..., additionally with vertical air deflection blades.
IB-Q-08-...	same as IB-Q-01-..., additionally with hit-and-miss damper.
IB-Q-8c-...	same as IB-Q-01-..., additionally with vertical pivoting air deflection blades and hit-and-miss damper.
IB-Q-10-...	pivoting vertical air deflection blades on the front side.
IB-Q-11-...	same as IB-Q-10-..., additionally with horizontal, pivoting air deflection blades.
IB-Q-15-...	same as IB-Q-10-..., additionally with hit-and-miss damper.
IB-Q-16-...	same as IB-Q-10-..., additionally with horizontal, pivoting air deflection blades and hit-and-miss damper.
IB-Q-...-N-...	single design
IB-Q-...-B-...	band design (only possible for IB-Q-10 / IB-Q-11 / IB-Q-15 / IB-Q-16, for a grille length BL > 1225 mm, available lengths according to SCHAKO standard for band design)

### Air throw pattern:

...-L000-...	blade position straight (standard)
...-L044-...	blade position 44° diverging
...-L084-...	blade position 84° diverging
...-L110-...	blade position 110° diverging (only for IB-Q-10 / IB-Q-11 / IB-Q-15 / IB-Q-16)
...-L140-...	blade position 140° diverging (only for IB-Q-10 / IB-Q-11 / IB-Q-15 / IB-Q-16)
...-LGEG-...	blade position opposite to one another

## MOUNTING

- Screw mounting (-SM, standard)
  - screws must be provided on site.
  - band design with screw mounting only.
- Concealed mounting (-VM)
  - only possible in connection with an installation frame or a plenum box.
- Clamp mounting (-KB)
  - only possible without plenum box or installation frame.

## PROCESSING

### Frame and blades

- Galvanised sheet steel (-SV-0000).
- Sheet steel (-SB):
  - Painted to RAL colour 9010 (white) (-9010, standard).
  - Painted to a different RAL colour, freely selectable (-xxxx, at an extra charge).

### Hit-and-miss damper

- Electrolytically galvanised sheet steel (only IB-Q-08 / IB-Q-8c / IB-Q-15 / IB-Q-16).

## ACCESSORIES

### Plenum box (-AK-31)

Rectangular design, made of galvanised sheet steel (-SV, standard), housing with round connection spigot and mounting brackets.

- Length:
  - 325 mm (-00325)
  - 425 mm (-00425)
  - 525 mm (-00525)
  - 625 mm (-00625)
  - 825 mm (-00825)
  - 1025 mm (-01025)
  - 1225 mm (-01225)
  - Length in mm, freely selectable, for band design (for a grille length  $BL > 1225$  mm: 2-part for a length of band  $BL \leq 2425$  mm, multi-part for a length of band  $BL > 2425$  mm) (-xxxxx, always with 5 digits).
- Height:
  - 75 mm (-075)
  - 125 mm (-125)
  - 175 mm (-175)
  - 225 mm (-225)
  - 325 mm (-325)
- Single / band design:
  - Single design (-N) (standard)
  - Band design (-B) (only possible for IB-Q-10 / IB-Q-11 / IB-Q-15 / IB-Q-16, for a grille length  $BL > 1225$  mm, available lengths according to SCHAKO standard for band design).
- Mounting:
  - screw mounting (-SM) (standard, screws must be provided on site, band design with screw mounting only)
  - concealed mounting (-VM) (only possible in combination with a plenum box or an installation frame)
- Damper:
  - without damper (-DK0) (standard).
  - with damper (-DK1), made of galvanised sheet steel, in the plenum box housing, adjustable, for simple air volume regulation.
  - with damper (-DK2), same as DK1, but with cable-operated adjustment, only with spigot position from above (-S0) and front side spigot position (-S4).
- Rubber lip seal:
  - without rubber lip seal (-GD0) (standard).
  - with rubber lip seal (-GD1) made of special rubber, at the connection spigot.
- Insulation:
  - without insulation (-I0) (standard).
  - with internal insulation (-Ii), thermal insulation inside the plenum box.
  - with external insulation (-Ia), thermal insulation at the outside of the plenum box.
- Height of plenum box:
  - Standard height of plenum box (-KHS).
  - Height of plenum box in mm, freely selectable (-xxx) (minimum height [KHS] with spigot position  $S1+S2 =$  spigot diameter +87 mm, but at least 200 mm) (always with 3 digits).

- Spigot diameter:
  - Standard spigot diameter (-SDS).
  - Spigot diameter in mm, freely selectable (-xxx, always with 3 digits). (with spigot positions -S0 and -S4, if the spigot diameter is increased, only the offset plenum box shape is available)
- Spigot position:
  - Spigot from above (-S0).
  - Lateral spigot on the plenum box (-S1) (standard).
  - Front side spigot (-S4, not possible for band design).

### Installation frame (-ER0 / -ER1 / -ER2)

- without installation frame (-ER0).
- with installation frame made of galvanised sheet steel (only possible in the absence of a plenum box):
  - without wall anchors (-ER1).
  - with wall anchors (-ER2).

## DIMENSIONS

### SINGLE DESIGN (-N)

#### IB-Q-01-...

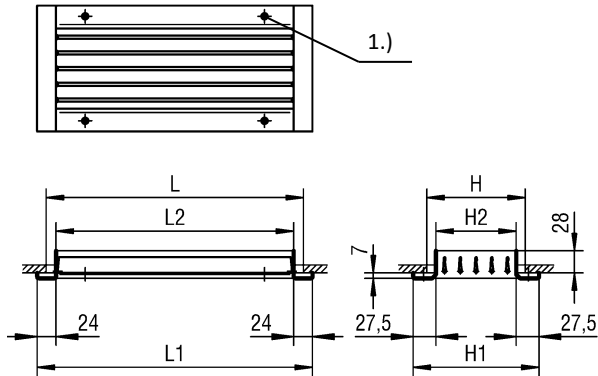

IB-Q-01 / IB-Q-02 / IB-Q-08 / IB-Q-8c  
 with intermediate web for lengths from 825 (see page 10)

All models consist of basic type IB-Q-01-...:

#### IB-Q-02-...

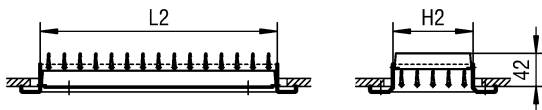

#### IB-Q-08-...

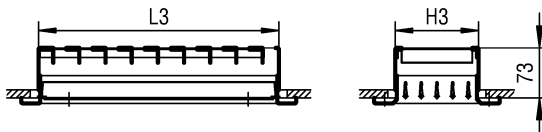

#### IB-Q-8c-...



Available sizes IB-Q-01 / IB-Q-02 / IB-Q-08 / IB-Q-8c

L	L1	L2	L3	H	H1	H2	H3
325	350	306	310	75	110	57	60
425	450	406	410	125	160	107	110
525	550	506	510	175	210	157	160
625	650	606	610	225	260	207	210
825	850	806	810	325	360	307	310
1025	1050	1006	1010				
1225	1250	1206	1210				

All combined lengths and heights available!  
 Other sizes available on request.

1.) Indentation for slotted shallow-raised countersunk-head tapping screw DIN ISO 7051 pitch 3.9 (on site).

#### IB-Q-10-...

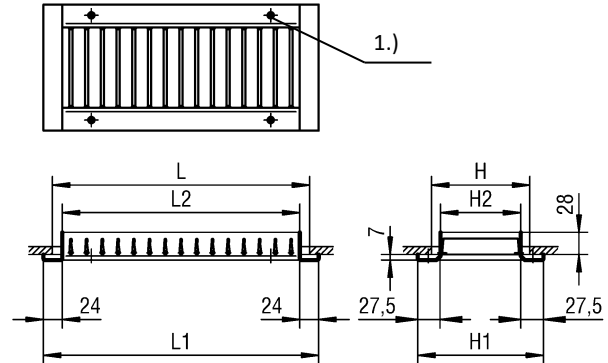

IB-Q-11 / IB-Q-16  
 with intermediate web for lengths from 825 (see page 10)

All models consist of basic type IB-Q-10-...:

#### IB-Q-11-...

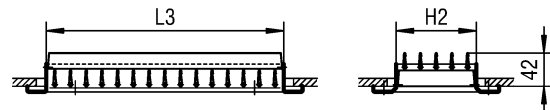

#### IB-Q-15-...

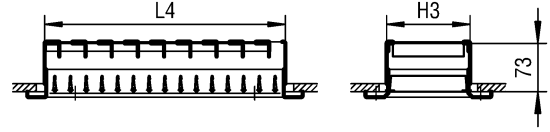

#### IB-Q-16-...

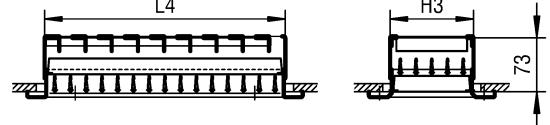

Available sizes IB-Q-10 / IB-Q-11 / IB-Q-15 / IB-Q-16

L	L1	L2	L3	L4	H	H1	H2	H3
325	350	306	309	310	75	110	56	60
425	450	406	409	410	125	160	106	110
525	550	506	509	510	175	210	156	160
625	650	606	609	610	225	260	206	210
825	850	806	809	810	325	360	306	310
1025	1050	1006	1009	1010				
1225	1250	1206	1209	1210				

All combined lengths and heights available!  
 Other sizes available on request.

1.) Indentation for slotted shallow-raised countersunk-head tapping screw DIN ISO 7051 pitch 3.9 (on site).

**BAND DESIGN (-B)**

Band design is only possible with screw mounting (-SM).

**Available lengths according to SCHAKO standard:**

In the band design of the ventilation grille IB-Q, the total length BL is assembled from two end pieces in the 2-part model and from sections (TS) of 1020 mm and end pieces (ES) in the multi-part model.

**Without plenum box**

only for: IB-Q-10-...-B-...-SM / IB-Q-11-...-B-...-SM /  
 IB-Q-15-...-B-...-SM / IB-Q-16-...-B-...-SM

**2-part for a length of band BL > 1225 mm to ≤ 2425 mm**

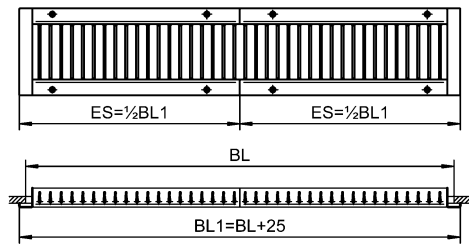

**multi-part for a length of band BL > 2425 mm**

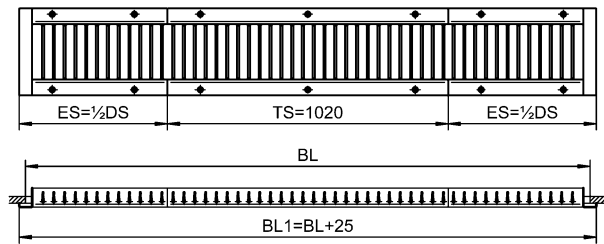

**Max. length end piece (ES):**

$ES_{max} = 1225 \text{ mm}$

- ES = end piece
- KES = plenum box end piece (KES = ES-20)
- TS = section
- KTS = plenum box section
- DS = difference piece (DS = BL1 - [n x TS])
- n = number of sections
- BL = band length

For spigot position / plenum box shape, see pages 6+7  
 For mounting options, see page 10

**with plenum box**

only for: IB-Q-10-...-B-...-SM / IB-Q-11-...-B-...-SM /  
 IB-Q-15-...-B-...-SM / IB-Q-16-...-B-...-SM

**2-part for a length of band BL > 1225 mm to ≤ 2425 mm**

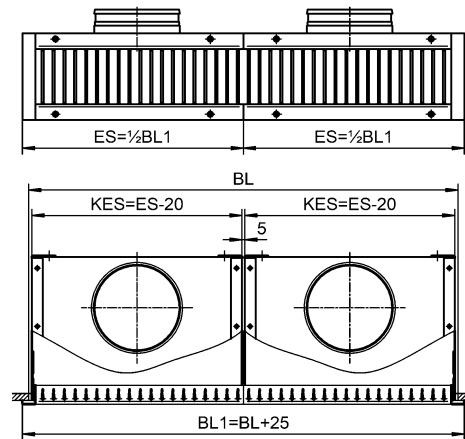

**multi-part for a length of band BL > 2425 mm**

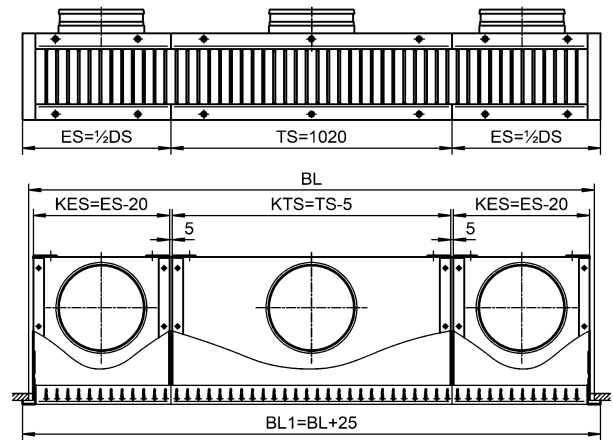

**Max. length plenum box end piece (KES):**

$KES_{max} = 1205 \text{ mm}$

**Minimum distance spigot in the plenum box**

with lateral spigot (-S1):      with spigot from above (-S0):



As standard, the plenum box end pieces (KES) have the same dimensions KHS / KB2 / øD as the plenum box section (KTS) (for dimensions see the table of available sizes, page 7, marking \*).

**DIMENSIONS OF ACCESSORIES**

**Plenum box (-AK-31)**

**SINGLE DESIGN (-N)**

**Spigot position**

**Straight plenum box:**

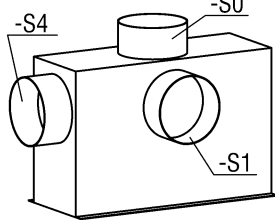

**Offset plenum box:**

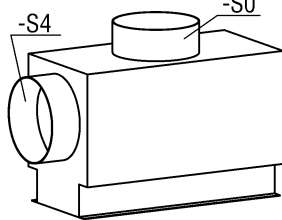

- Lateral spigot on the plenum box (-S1, standard)
- Spigot from above (-S0)
- Front side spigot (-S4, not possible for band design)

Spigot diameter for spigot position "Spigot front side (-S4)" is identical with "Lateral spigot on the box (-S1)".

Spigot diameter for spigot position "Spigot from above (-S0)" is in part not identical with "Lateral spigot on the box (-S1)".

For the table of available sizes, see page 7.

**Straight plenum box:**

**with spigot from above (-S0)**

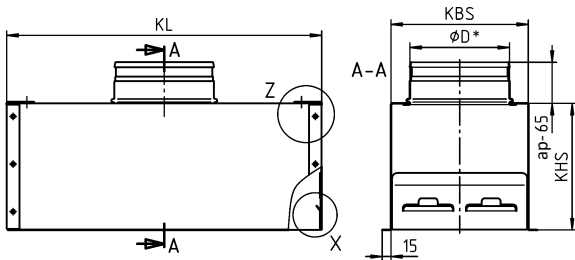

**with lateral spigot on the plenum box (-S1)**

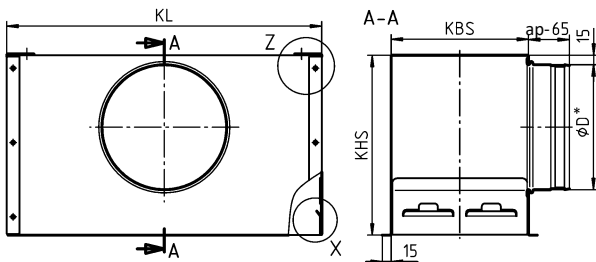

**with spigot front side (-S4)**

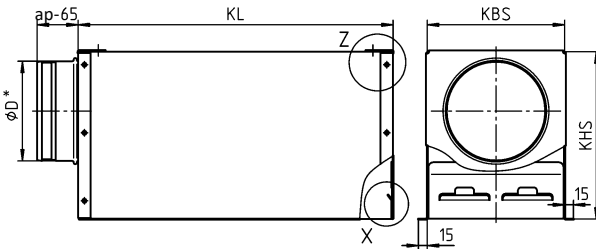

\* external

For plenum box in band design, see page 5.

**Offset plenum box:**

If KBS is  $< (\phi D + 30)$ , an offset plenum box will be manufactured.

For model -S0:  $KB2 = \phi D + 30$

Minimum difference between KBS and KB2 = 40 mm.

**with spigot from above (-S0)**

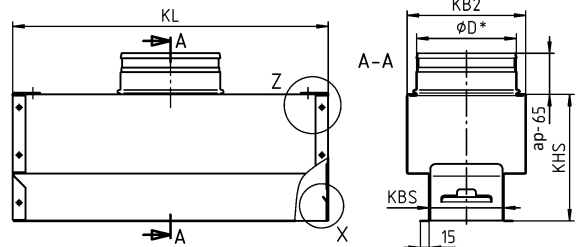

**with lateral spigot on the plenum box (-S4)**

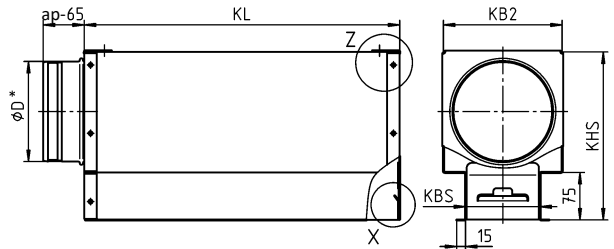

\* external

**Plenum box mounting:**

**Detail Z**

as-delivered condition with fitted fixing lug

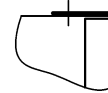

**Detail Z**

with bent fixing lug

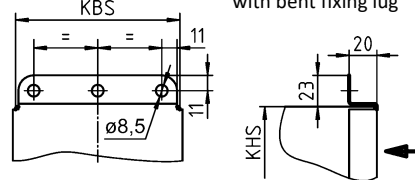

**Concealed mounting:**

**Detail X**

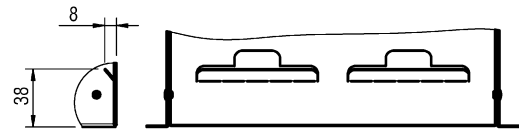

Concealed plates can be bent outwards, if necessary.

Minimum height KHS with spigot position -S1 / -S4:

**$KHS_{min.} = \phi D + 87$  mm, but at least 200 mm**

Minimum width KB2 with spigot position -S0 / -S4:

**$KB2_{min.} = \phi D + 30$  mm**

Minimum difference between KBS and KB2 = 40 mm.

The dimension KBS cannot be changed.

With spigot positions -S0 and -S4, if the spigot diameter is increased, only the offset plenum box shape is available.

Available sizes for AK-31

H	KBS	L	KL	Spigot position -S1 (standard)				Spigot position -S0				Spigot position -S4			
				KHS	KB2	n x ØD	Plenum box shape	KHS	KB2	n x ØD	Plenum box shape	KHS	KB2	n x ØD	Plenum box shape
75	68	325	320	220	--	1x Ø123		200*	128*		220	153	1x Ø123		
		425	420												1x Ø98
		525	520												
		625	620	265*	--	1x Ø158*		4x Ø98*	265	188	1x Ø158				
		825	820												
		1025	1020												
1225	1220														
125	118	325	320	265	--	1x Ø158		200*	158*		265	188	1x Ø158		
		425	420												1x Ø98
		525	520												
		625	620	285*	--	1x Ø198*		4x Ø98*	285	228	1x Ø198				
		825	820												
		1025	1020												
1225	1220														
175	168	325	320	285*	--	1x Ø198*		200*	228*		285	228	1x Ø198		
		425	420												
		525	520												
		625	620												
		825	820												
		1025	1020												
1225	1220														
225	218	325	320	285	--	1x Ø198		200*	258	1x Ø198	285	258	1x Ø198		
		425	420												2x Ø178*
		525	520												
		625	620	335*	--	1x Ø248*		2x Ø178*	335	278	1x Ø248				
		825	820												
		1025	1020												
1225	1220														
325	318	325	320	335	--	1x Ø248		200*	--	1x Ø248	335	--	1x Ø248		
		425	420												2x Ø222*
		525	520												
		625	620	400*	--	1x Ø313*		2x Ø222*	400	358	1x Ø313				
		825	820												
		1025	1020												
1225	1220														

**Number of spigots:**  
**Spigot from above (-S0)**

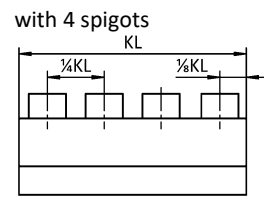
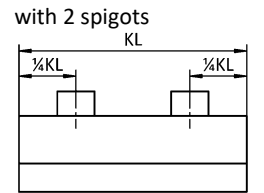
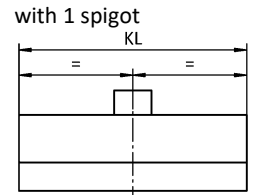

**Lateral spigot (-S1)**  
 (standard)

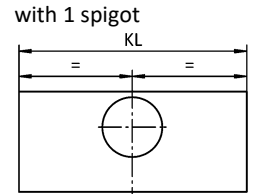

**Spigot front side (-S4)**  
 Band design not possible.

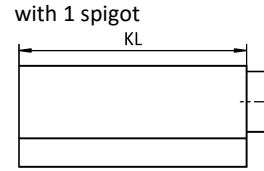

\* dimensions for band design / n = number of spigots

**Plenum box shape**

**Straight:**

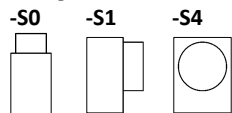

**Offset:**

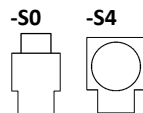

Minimum height KHS with spigot position -S1 / -S4:

**KHS<sub>min.</sub> = ØD + 87 mm, but at least 200 mm**

Minimum width KB2 with spigot position -S0 / -S4:

**KB2<sub>min.</sub> = ØD + 30 mm**

Minimum difference between KBS and KB2 = 40 mm.

**The dimension KBS cannot be changed.**

**With spigot positions -S0 and -S4, if the spigot diameter is increased, only the offset plenum box shape is available.**

### Damper (-DK0 / -DK1 / -DK2), for AK-...

- without damper (-DK0) (standard).
- with damper (-DK1) (standard for spigot position -S1).
- with damper and cable-operated adjustment (-DK2) (standard for spigot position -S0/-S4).

#### -DK1:

Lateral spigot -S1

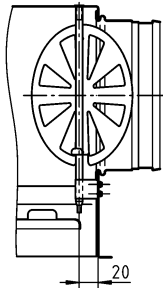

#### -DK2 (with cable-operated adjustment):

Spigot from above -S0

Spigot front side -S4

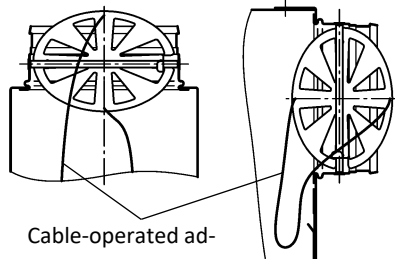

### Rubber lip seal (-GD0 / -GD1), for AK-...

- without rubber lip seal (-GD0) (standard).
- with rubber lip seal (-GD1), made of special rubber.

#### Detail Y

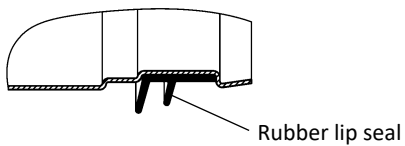

### Insulation (-I0 / -li / -Ia), for AK-...

- without insulation (-I0) (standard).
- with internal insulation (-li).
- with external insulation (-Ia).

#### Internal insulation (-li)

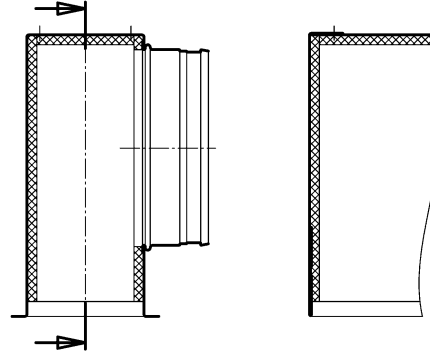

#### External insulation (-Ia)

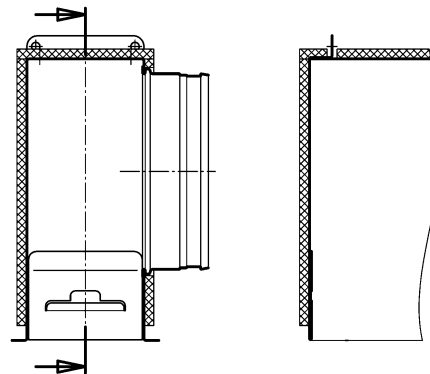

### Installation frame (-ER0 / -ER1 / -ER2)

- without installation frame (-ER0) (standard).
- with installation frame without wall anchors (-ER1).
- with installation frame with wall anchors (-ER2).

The installation frame is only possible in the absence of a plenum box.

### SINGLE DESIGN (-N)

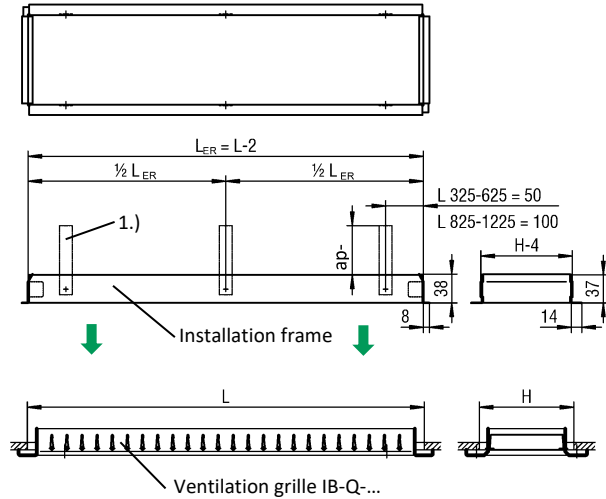

Length  $L \leq 825 \text{ mm} = 4$  wall anchors

Length  $L > 825 \text{ mm} = 6$  wall anchors

Installation frame E1 made of electrolytic galvanised sheet steel.

The installation frame is only delivered with wall anchors on special request (-ER2, at an extra charge).

### BAND DESIGN (-B)

#### 2-part for a length of band BL > 1225 mm to ≤ 2425 mm

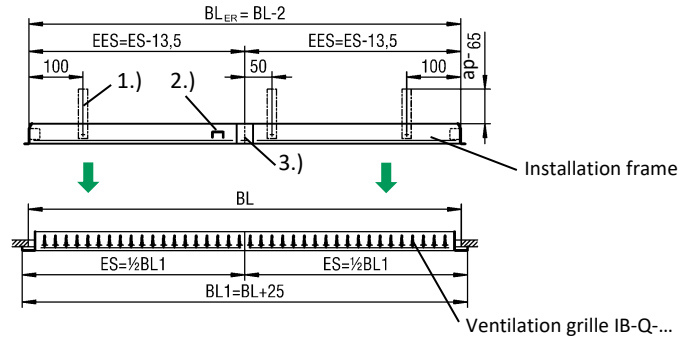

#### multi-part for a band length BL > 2425 mm

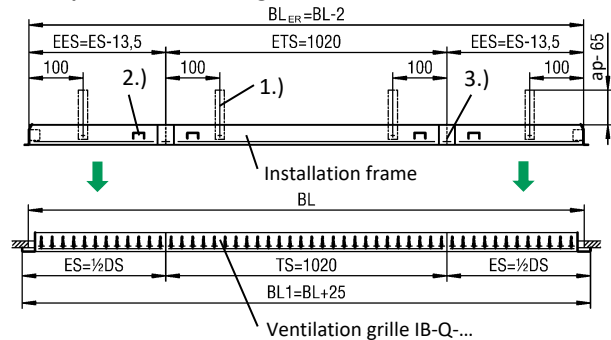

#### Max. length installation frame end piece (EES / ES):

$EES_{max} = 1211.5 \text{ mm} / ES_{max} = 1225 \text{ mm}$  (see page 5)

Mounting frames for grille bands are supplied with plug-in connections. Assembly webs are additionally attached, they can easily be removed with a turn, once the grille is walled in. All mounting frames are supplied without wall anchors as standard. Wall anchors available at extra cost.

#### Installation detail:

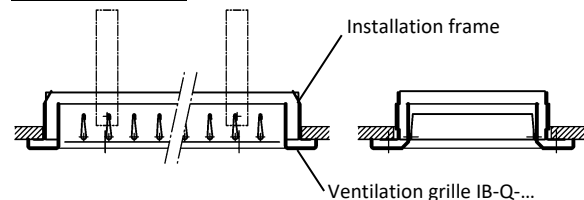

- L = length
- BL = band length
- $L_{ER}$  = installation frame length ( $L_{ER} = L - 2$ )
- $BL_{ER}$  = installation frame band length ( $BL_{ER} = BL - 2$ )
- EES = installation frame end piece ( $EES = ES - 13.5$ )
- ETS = installation frame section
- ES = end piece
- TS = section
- DS = difference piece ( $DS = BL_{ER} - [n \times TS]$ )
- n = number of sections
- 1.) Wall anchor
- 2.) Assembly rail
- 3.) Plug-in connection

**MOUNTING OPTIONS**

**Screw mounting (-SM, standard)**

**SINGLE DESIGN (-N)**

L=325-525

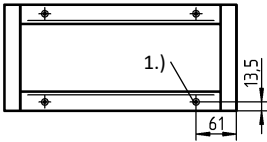

L= 625

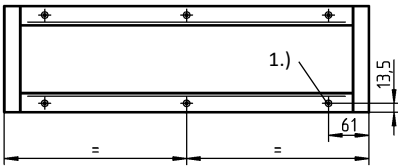

L=825-1225

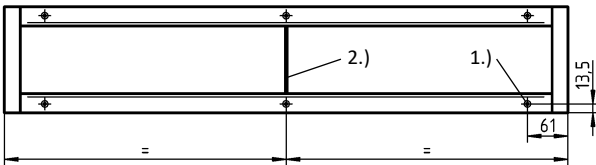

**BAND DESIGN (-B)**

2-part for a length of band BL > 1225 mm to ≤ 2425 mm

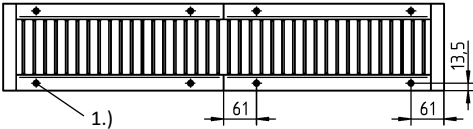

multi-part for a band length BL > 2425 mm

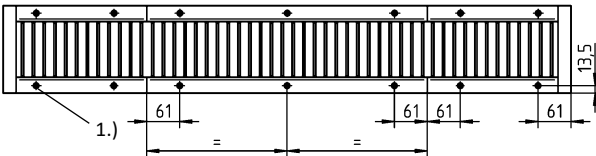

- 1.) With 4 or 6 indentations (from L=625) for slotted shallow-raised countersunk-head tapping screw DIN ISO 7051 pitch 3.9 (on site).
- 2.) Intermediate rail (only for IB-Q with horizontal blades).

**Concealed mounting (-VM)**

The IB-Q ventilation grilles are delivered at an extra charge with concealed mounting (-VM). **The concealed mounting is only possible with an installation frame or a plenum box.**

With installation frame

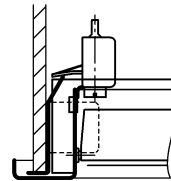

With plenum box

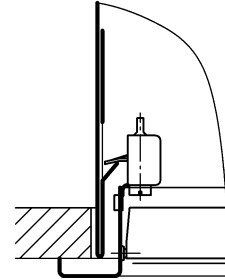

One mounting point:  
H = 75 / 125 / 175

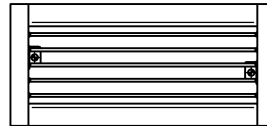

Two mounting points:  
H = 225 / 325

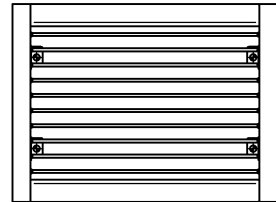

**Clamp mounting (-KB)**

Clamp mounting KB is possible without installation frame or plenum box.

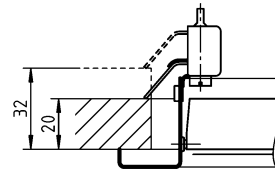

One mounting point:  
H = 75 / 125 / 175

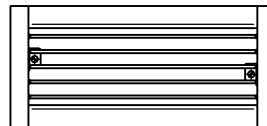

Two mounting points:  
H = 225 / 325

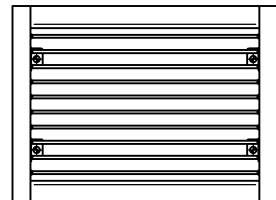

**TECHNICAL DATA**

**Pressure loss and noise level**

**Supply air face velocity**

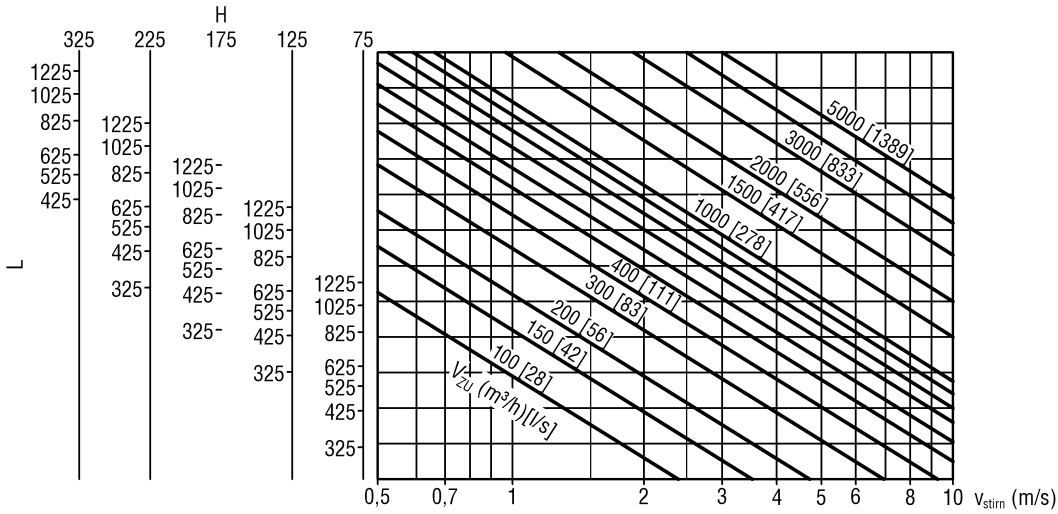

**IB-Q-... (supply air)**

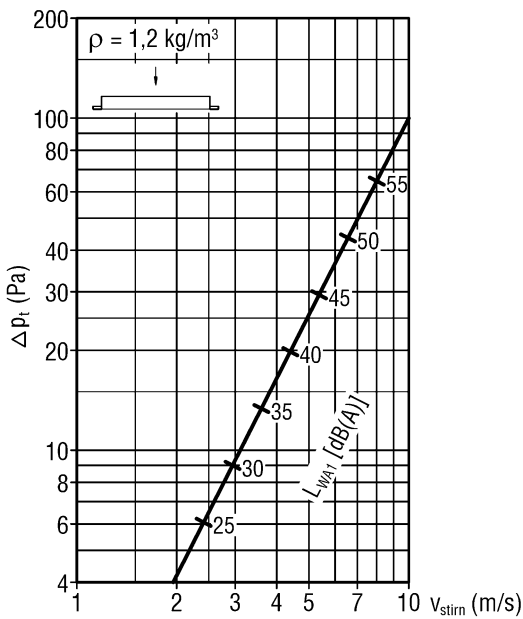

**IB-Q-... with hit-and-miss damper (supply air)**

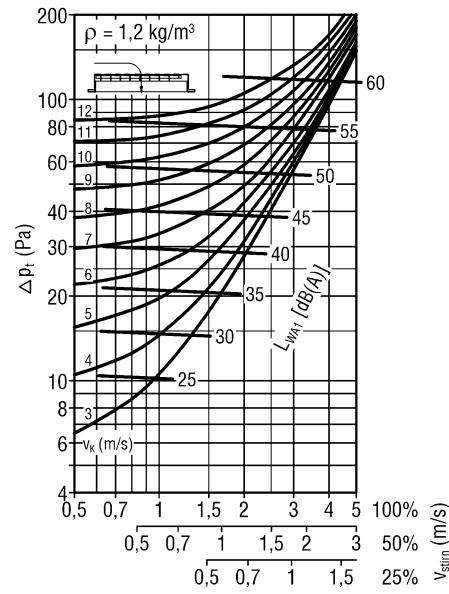

Hit-and-miss damper position OPEN in %

**Pressure loss and noise level**

**Return air face velocity**

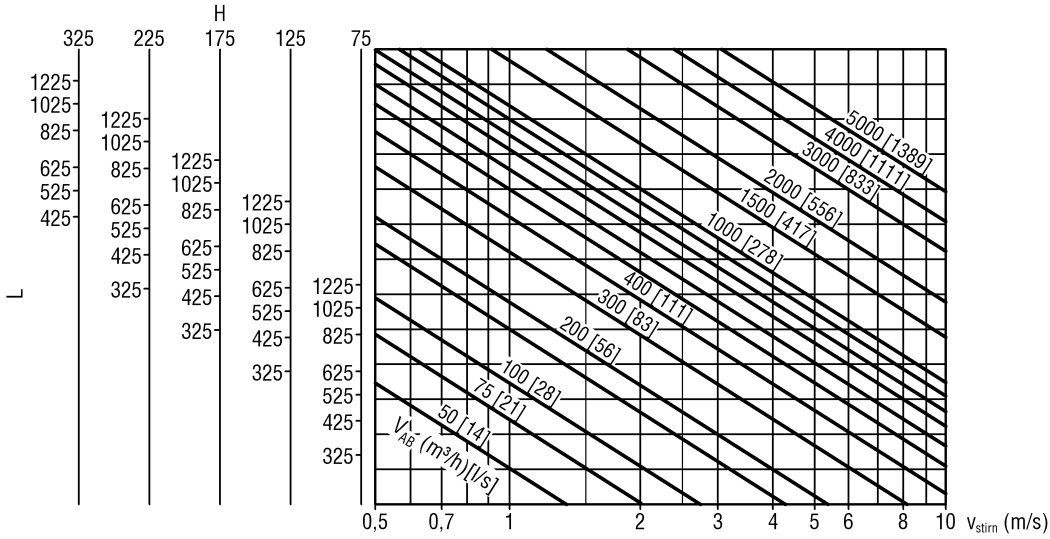

**IB-Q-... (return air)**

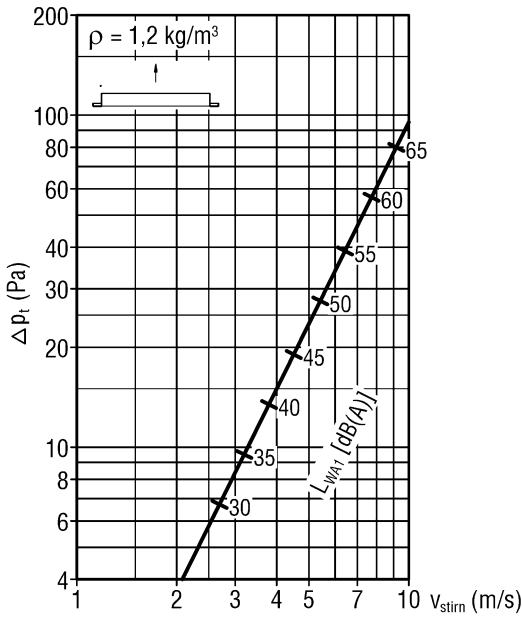

**IB-Q-... with hit-and-miss damper (return air)**

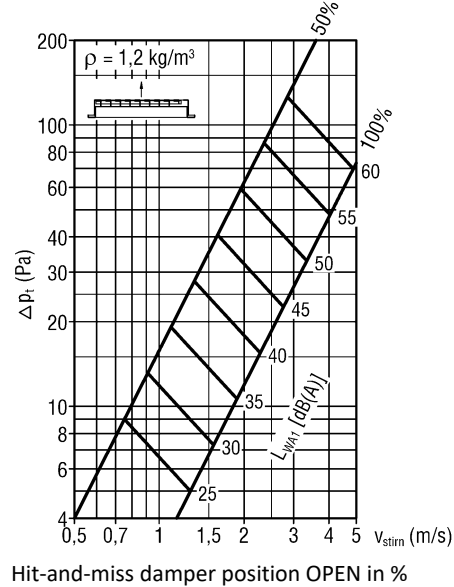

**Face area**

Supply and return air (m<sup>2</sup>)

Height H	Length L (mm)							
	325	425	525	625	825	1025	1225	
75	0.016	0.021	0.026	0.031	0.042	0.052	0.062	
125	0.031	0.041	0.051	0.061	0.082	0.102	0.123	
175	0.046	0.061	0.076	0.092	0.122	0.152	0.183	
225	0.061	0.081	0.101	0.122	0.162	0.202	0.243	
325	-	0.121	0.151	0.182	0.242	0.313	0.363	
<b>A<sub>stirn</sub> (m<sup>2</sup>)</b>								

**Supply air correction factor**

A <sub>stirn</sub> (m <sup>2</sup> )	0.012	0.025	0.05	0.1	0.16	0.2	0.4
KF (-)	-9	-6	-3	0	+2	+3	+6

**Return air correction factor**

A <sub>stirn</sub> (m <sup>2</sup> )	0.01	0.02	0.04	0.08	0.16	0.32	0.4
KF (-)	-9	-6	-3	0	+3	+6	+7

$L_{WA} = L_{WA1} + KF$

**Maximum end velocity of jet**  
**Supply air without coanda effect**

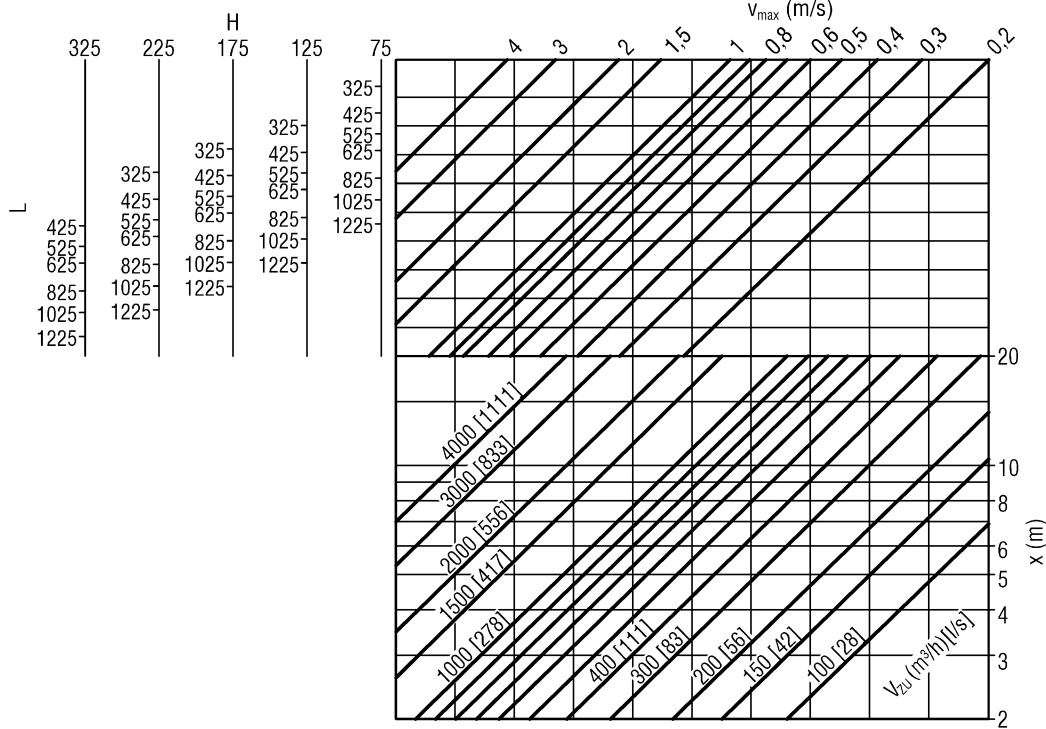

**Supply air with coanda effect**

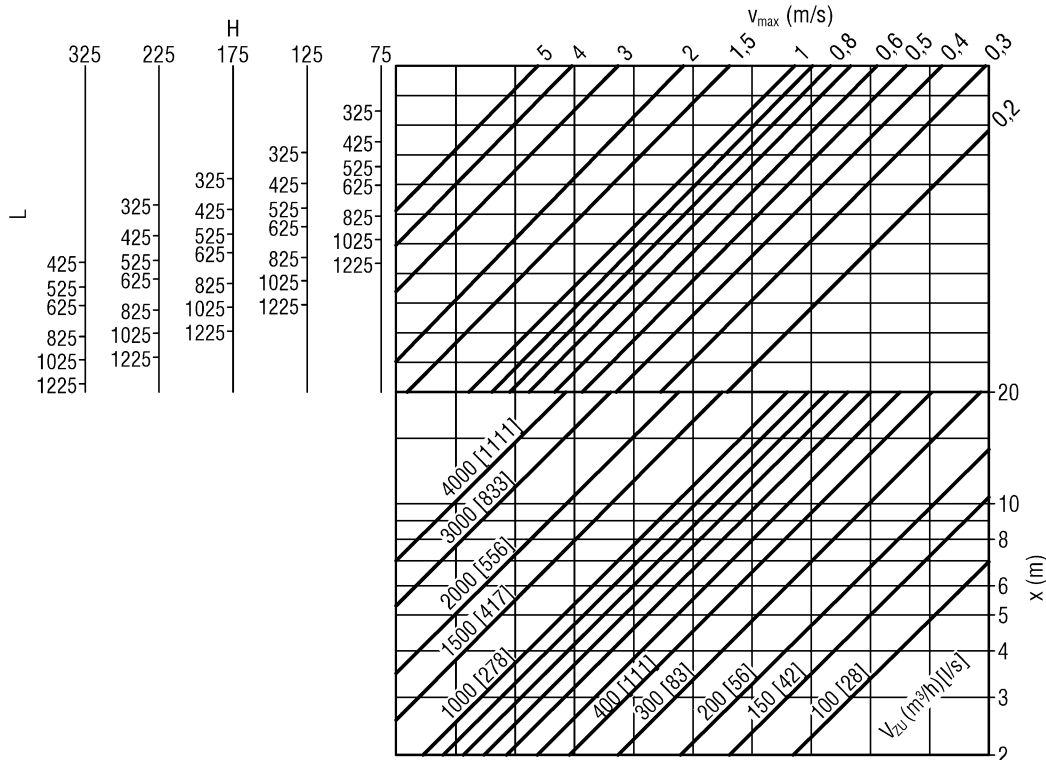

**Jet path**

**Supply air without coanda effect**

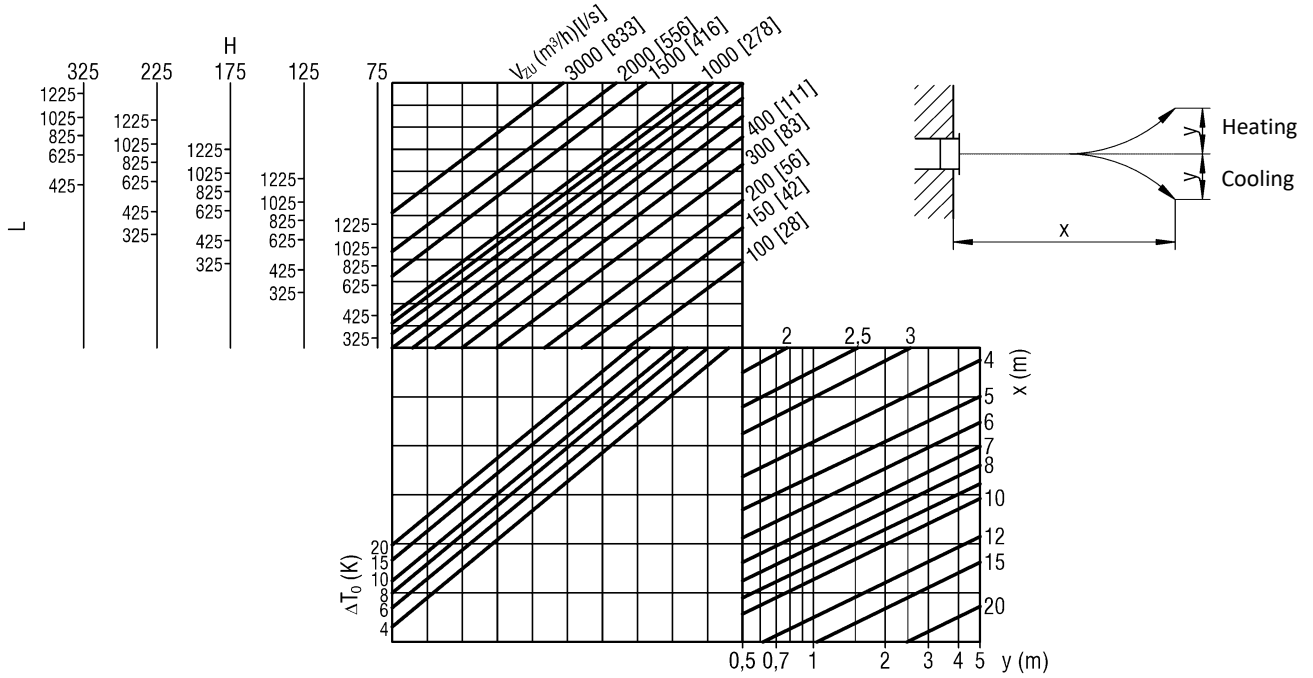

**Critical throw**

**Supply air with coanda effect**

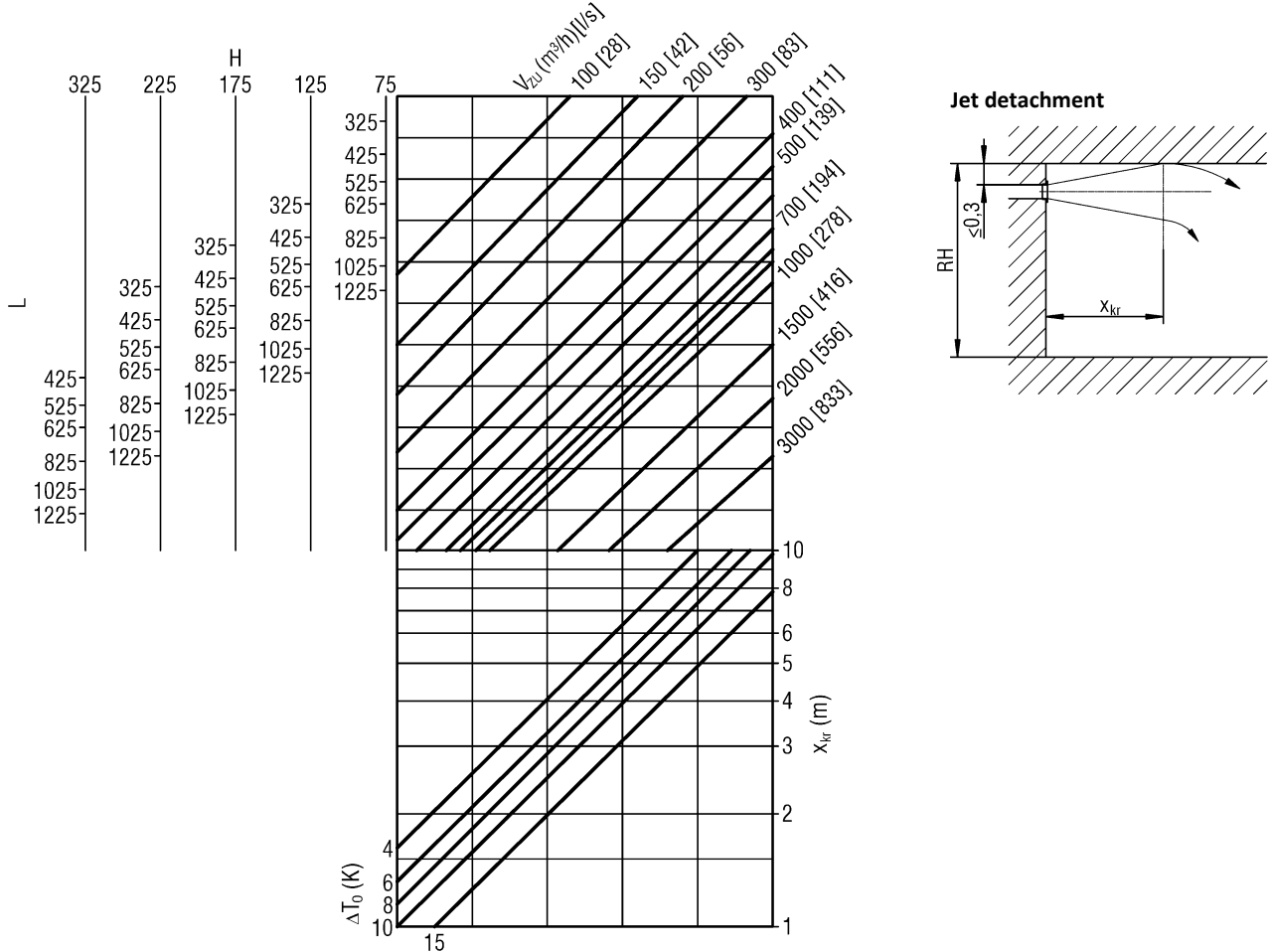

**Maximum penetration**

Maximum vertical penetration depth (in heating mode)

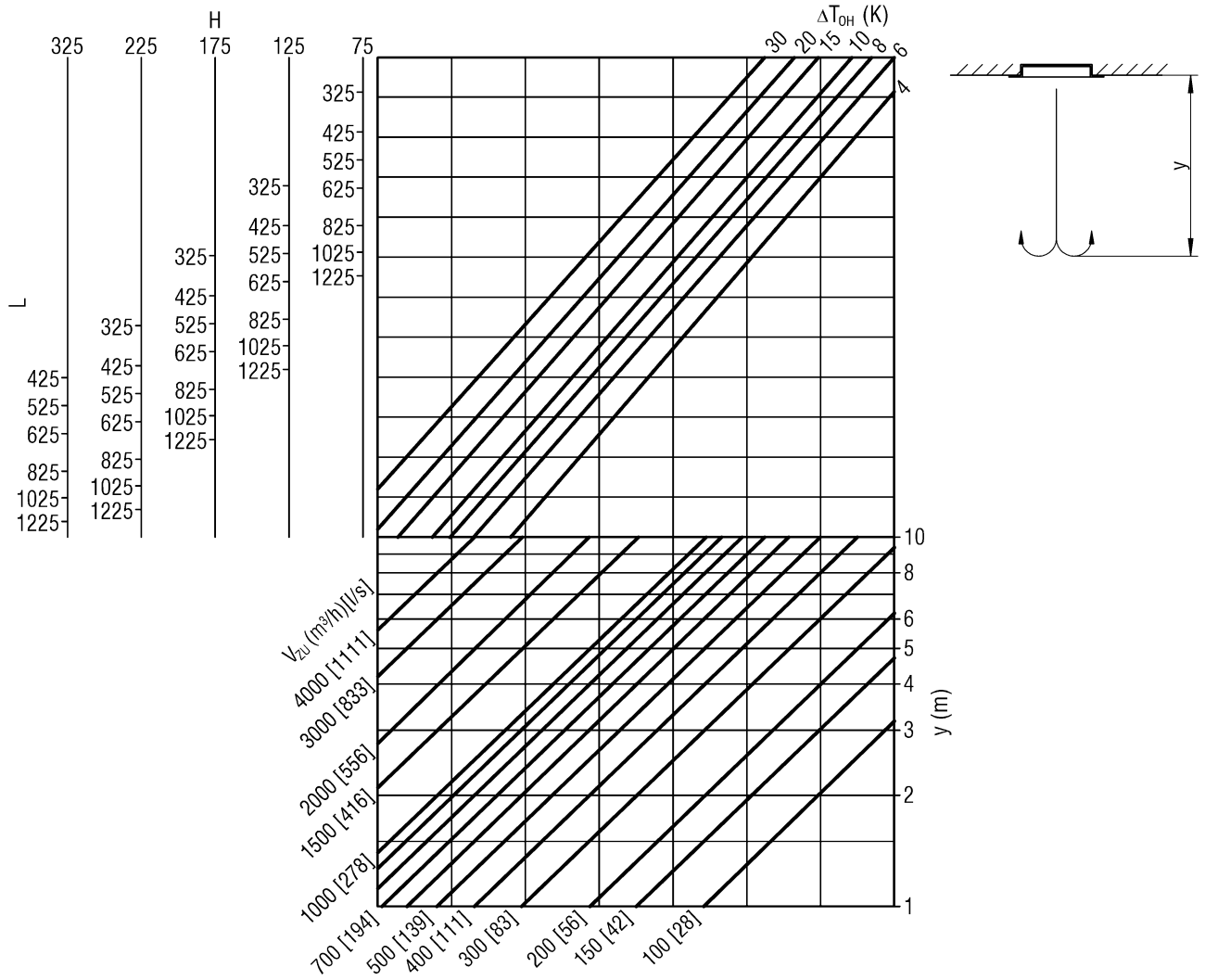

**Temperature and induction ratios**

**Supply air without coanda effect**

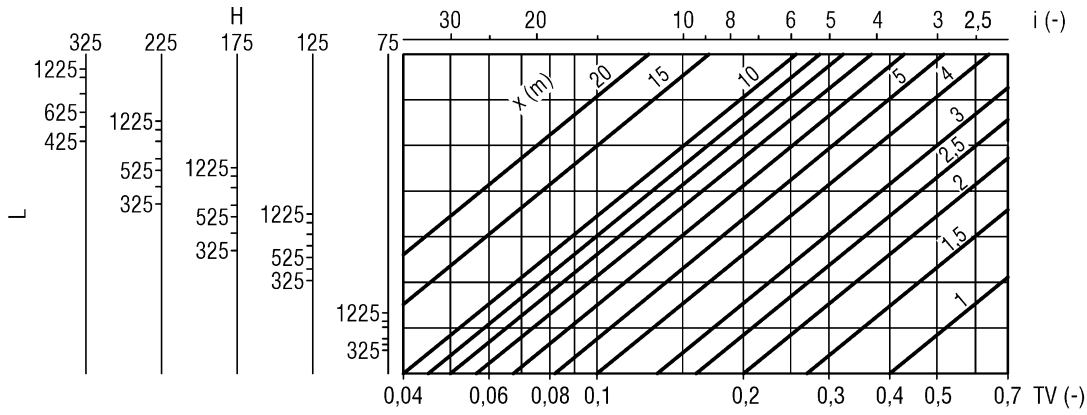

**Supply air with coanda effect**

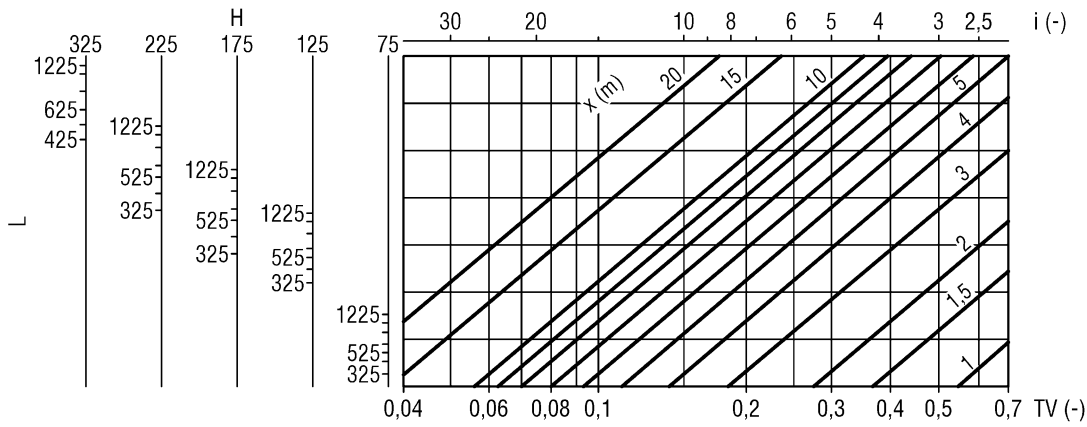

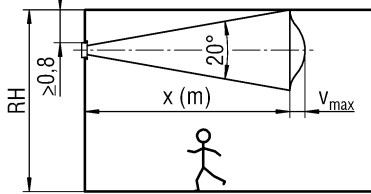
**Minimum distances**
**Supply air without coanda effect**

For the diagrams to be correct, the distance  $z$  between two grilles must be  $\geq x$  (m)  $\times 0.2$ .

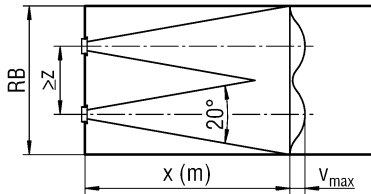
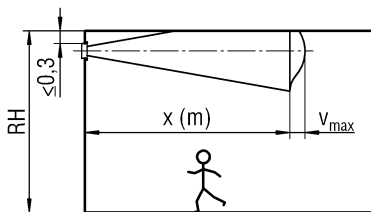
**Supply air with coanda effect**

For the diagrams to be correct, the distance  $z$  between two grilles must be  $\geq x$  (m)  $\times 0.2$ .

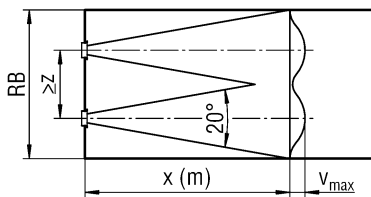
**Correction factor**

(for scattered air jet)

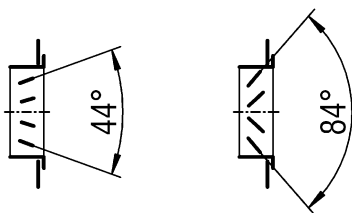
**with or without coanda effect**

Blade position	44°	84°
End velocity of jet	$v_{\max}$ (m/s) $\times 0.65$	$v_{\max}$ (m/s) $\times 0.5$
Critical throw $x_{kr}$	$\times 0.77$	$\times 0.6$
$TV = \Delta T_x / \Delta T_0$	$\times 0.65$	$\times 0.5$
Induction ratio	$i \times 1.3$	$i \times 2$
Jet drop - Jet rise	$y \times 1.3$	$y \times 2$
Grille spacing $z$ (m)	$x \times 0.20$	$x \times 0.25$

**Blade position**
**Blade position straight (-L000)**

**Blade position opposite to one another (-LGEG)**

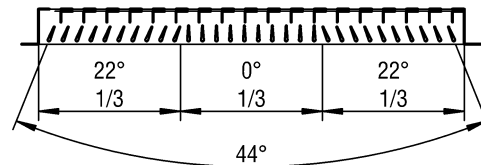
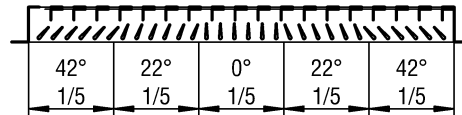
**Blade position 44° diverging (-L044)**

**Blade position 84° diverging (-L084)**

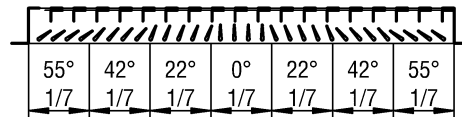
**Blade position 110° diverging (-L110)**

(only for IB-Q-10 / IB-Q-11 / IB-Q-15 / IB-Q-16)

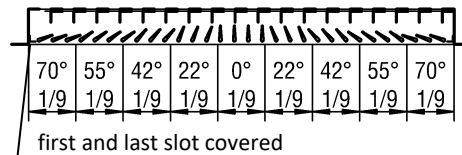
**Blade position 140° diverging (-L140)**

(only for IB-Q-10 / IB-Q-11 / IB-Q-15 / IB-Q-16)

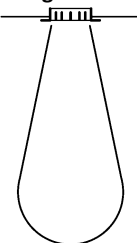
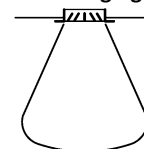

The angle of propagation of the air jet and thus the length of throw can be affected by adjusting the vertical air deflection blades.

**Blade position:**
**straight**

**diverging**

## LEGEND

$V_{ZU}$	(m <sup>3</sup> /h) [l/s]	= Supply air volume
$V_{AB}$	(m <sup>3</sup> /h) [l/s]	= Return air volume
$V_x$	(m <sup>3</sup> /h) [l/s]	= total air jet volume at point x
$v_{max}$	(m/s)	= max. End velocity of jet
$v_K$	(m/s)	= duct velocity
$v_{stirn}$	(m/s)	= intake velocity, blower stream velocity, outflow velocity, relative to $A_{stirn}$
$A_{stirn}$	(m <sup>2</sup> )	= face area
x	(m)	= horizontal throw
y	(m)	= vertical throw
$x_{kr}$	(m)	= critical throw
$\rho$	(kg/m <sup>3</sup> )	= Density
$\Delta p_t$	(Pa)	= pressure loss
$L_{WA}$	[dB(A)]	= A-weighted sound power level ( $L_{WA} = L_{WA1} + KF$ )
$L_{WA1}$	[dB(A)]	= A-weighted sound power level, relative to $A_{stirn} = 0.08 \text{ m}^2$
KF	(-)	= Correction factor
$\Delta T_O$	(K)	= Temperature difference between supply air and room temperature ( $\Delta T_O = t_{ZU} - t_R$ )
$\Delta T_{OH}$	(K)	= Temperature difference between air supply and ambient temperature in heating mode ( $\Delta T_{OH} = t_{ZU} - t_{RH}$ )
$\Delta T_x$	(K)	= Temperature difference at point x
$t_{ZU}$	(°C)	= supply air temperature
$t_R$	(°C)	= room temperature
i	(-)	= induction ratio ( $i = V_x / V_{ZU}$ )
TV	(-)	= Temperature ratio ( $TV = \Delta T_x / \Delta T_O$ )
z	(m)	= minimum clearance between two grilles $x \text{ (m)} \times 0.2$
RH	(mm)	= room height
RB	(mm)	= room width
L	(mm)	= length
H	(mm)	= Height

## ORDER CODE IB

01	02	03	04	05	06
Type	Model	Blades	Length	Height	Single / band design
<b>Example</b>					
IB	-Q	-01	-00625	-125	-N

07	08	09	10	11
Air throw pattern	Material	Paint	Mounting	Installation frame
-L000	-SB	-9010	-SM	-ERO

All fields must be filled when ordering.

### Sample

**IB-Q-01-00625-125-N-L000-SB-9010-SM-ERO**

Ventilation grille IB | for duct and plenum box installation | horizontal, pivoting air deflection blades on the front side | grille length 625 mm | grille height 125 mm | single design | blade position straight | sheet steel | painted to RAL 9010 (white) | screw mounting | without installation frame

## ORDER DETAILS

### 01 - Type

IB = ventilation grille IB

### 02 - Model

Q = for duct and plenum box installation

### 03 - Blades

- 01 = horizontal pivoting air deflection blades on the front side
- 02 = same as IB-Q-01, additionally with vertical, pivoting air deflection blades
- 08 = same as IB-Q-01, additionally with hit-and-miss damper
- 8c = same as IB-Q-01, additionally with vertical pivoting air deflection blades and hit-and-miss damper
- 10 = vertical, pivoting air deflection blades on the front side
- 11 = same as IB-Q-10, additionally with horizontal, pivoting air deflection blades
- 15 = same as IB-Q-10, additionally with hit-and-miss damper
- 16 = same as IB-Q-10, additionally with horizontal pivoting air deflection blades and hit-and-miss damper

### 04 - Length

- 00325 = grille length 325 mm
- 00425 = grille length 425 mm
- 00525 = grille length 525 mm
- 00625 = grille length 625 mm
- 00825 = grille length 825 mm
- 01025 = grille length 1025 mm
- 01225 = grille length 1225 mm
- xxxxx = length in mm, for band design (for a grille length BL > 1225 mm: 2-part for a length of band BL ≤ 2425 mm, multi-part for a length of band > 2425 mm) (always with 5 digits).

### 05 - Height

- 075 = grille height 75 mm
- 125 = grille height 125 mm
- 175 = grille height 175 mm
- 225 = grille height 225 mm
- 325 = grille height 325 mm

### 06 - Single / band design

- N = single design
- B = band design (only possible for IB-Q-10 / IB-Q-11 / IB-Q-15 / IB-Q-16, for a grille length BL > 1225 mm, module length max. 1225 mm, available lengths according to SCHAKO standard for band design)

### 07 - Air throw pattern

- L000 = blade position straight (standard)
- L044 = blade position 44° diverging
- L084 = blade position 84° diverging
- L110 = blade position 110° diverging (only for IB-Q-10 / IB-Q-11 / IB-Q-15 / IB-Q-16)
- L140 = blade position 140° diverging (only for IB-Q-10 / IB-Q-11 / IB-Q-15 / IB-Q-16)
- LGEG = blade position opposite to one another

### 08 - Material

- SV = galvanised sheet steel
- SB = sheet steel (standard) (only available with paint)

### 09 - Paint

- 0000 = without paint (only -SV possible).
- 9010 = Painted to RAL colour 9010 (white, standard).
- xxxx = painted to a different RAL colour, freely selectable (always with 4 digits).

### 10 - Mounting

- SM = screw mounting (standard, with band design only SM possible).
- VM = concealed mounting (only possible with a plenum box or an installation frame).
- KB = clamp mounting (only possible without plenum box or installation frame).

### 11 - Installation frame

- ERO = without installation frame (standard)
  - ER1 = with installation frame without wall anchors
  - ER2 = with installation frame with wall anchors
- Installation frame only possible in the absence of a plenum box.

## ORDER CODE AK

01	02	03	04	05	06	07
Type	Air diffuser	Length	Height	Single / band design	Mounting	Material
<b>Example</b>						
AK	-31	-00325	-075	-N	-SM	-SV

08	09	10	11	12	13
Damper	Rubber lip seal	Insulation	Height of plenum box	Spigot diameter	Spigot position
-DK1	-GD1	-I0	-KHS	-SDS	-S1

### Sample

**AK-31-00325-075-N-SM-SV-DK1-GD1-I0-KHS-SDS-S1**

Plenum box, rectangular design I for ventilation grille IB-Q I length 325 mm I height 75 mm I single design I screw mounting I galvanised sheet steel I with damper | with rubber lip seal | without insulation | standard height of plenum box I standard spigot diameter | lateral spigot

### ORDER DETAILS

#### 01 - Type

AK = plenum box, rectangular design

#### 02 - Air diffuser

31 = for ventilation grille IB-Q-...

#### 03 - Length

00325 = grille length 325 mm  
 00425 = grille length 425 mm  
 00525 = grille length 525 mm  
 00625 = grille length 625 mm  
 00825 = grille length 825 mm  
 01025 = grille length 1025 mm  
 01225 = grille length 1225 mm  
 xxxxx = length in mm, freely selectable, for band design (for a grille length BL > 1225 mm: 2-part for a length of band BL ≤ 2425 mm, multi-part for a length of band > 2425 mm) (only possible for IB-Q-10 / IB-Q-11, always with 5 digits)

#### 04 - Height

075 = grille height 75 mm  
 125 = grille height 125 mm  
 175 = grille height 175 mm  
 225 = grille height 225 mm  
 325 = grille height 325 mm

#### 05 - Single / band design

N = single design (standard)  
 B = band design (only possible for IB-Q-10 / IB-Q-11 / IB-Q-15 / IB-Q-16, for a grille length BL > 1225 mm, available lengths according to SCHAKO standard for band design)

#### 06 - Mounting

SM = screw mounting (standard, screws must be provided on site, with band design only SM possible).  
 VM = concealed mounting.

#### 07 - Material

SV = galvanised sheet steel (standard).

#### 08 - Damper

DK0 = without damper (standard).  
 DK1 = with damper (standard for spigot position -S1).  
 DK2 = with damper and cable-operated adjustment (standard for spigot position -S0 / -S4).

#### 09 - Rubber lip seal

GD0 = without rubber lip seal (standard).  
 GD1 = with rubber lip seal.

#### 10 - Insulation

I0 = without insulation (standard).  
 li = with internal insulation.  
 la = with external insulation.

#### 11 - Height of plenum box

KHS = standard height of plenum box.  
 xxx = height of plenum box in mm, freely selectable (minimum height [KHS] with spigot position S1+S2 = spigot diameter +87 mm, but at least 200 mm) (always with 3 digits).

#### 12 - Spigot diameter

SDS = spigot diameter standard.  
 xxx = spigot diameter in mm, can be freely selected (always with 3 digits).  
 (with spigot positions -S0 and -S4, if the spigot diameter is increased, only the offset plenum box shape is available)

#### 13 - Spigot position

S0 = spigot from above.  
 S1 = lateral spigot on the plenum box (standard).  
 S4 = front side spigot (not possible for band design).

## SPECIFICATION TEXT

Ventilation grille **type IB-Q-...** for supply and return air, for installation in ducts and plenum boxes, with horizontal or vertical, pivoting, individually adjustable air deflection blades on the front side. For description of frames and blades, see "Material / paint". Assembly parts made of electrolytically galvanised sheet steel.

Product: SCHAKO **type IB-Q-...**

### Model:

- horizontal pivoting air deflection blades on the front side (**-IB-Q-01-...**).
- same as IB-Q-01, additionally with vertical, pivoting air deflection blades (**-IB-Q-02-...**).
- same as IB-Q-01-..., additionally with hit-and-miss damper (**-IB-Q-08-...**).
- same as IB-Q-01-..., additionally with vertical, pivoting air deflection blades and hit-and-miss damper (**-IB-Q-8c-...**).
- vertical, pivoting air deflection blades on the front side (**-IB-Q-10-...**).
- same as IB-Q-10-..., additionally with horizontal, pivoting air deflection blades (**-IB-Q-11-...**).
- same as IB-Q-10-..., additionally with hit-and-miss damper (**-IB-Q-15-...**).
- same as IB-Q-10-..., additionally with horizontal, pivoting air deflection blades and hit-and-miss damper (**-IB-Q-16-...**).

### Length:

- 325 mm (**-00325**)
- 425 mm (**-00425**)
- 525 mm (**-00525**)
- 625 mm (**-00625**)
- 825 mm (**-00825**)
- 1025 mm (**-01025**)
- 1225 mm (**-01225**)
- length in mm, freely selectable, for band design (for a grille length BL > 1225 mm: 2-part for a length of band BL ≤ 2425 mm, multi-part for a length of band > 2425 mm) (-xxxxx, always with 5 digits).

### Height:

- 75 mm (**-075**)
- 125 mm (**-125**)
- 175 mm (**-175**)
- 225 mm (**-225**)
- 325 mm (**-325**)

### Material / paint (frames and blades):

- Galvanised sheet steel (**-SV**)
- Sheet steel (**-SB**, standard)
  - Painted to RAL colour 9010 (white) (**-9010**, standard)
  - Painted to a different RAL colour, freely selectable (**-xxxx**, at an extra charge, always with 4 digits)

### Single / band design:

- Single design (**-N**)
- band design (**-B**) (only possible for IB-Q-10 / IB-Q-11 / IB-Q-15 / IB-Q-16, for a grille length BL > 1225 mm, module length max. 1225 mm, available lengths according to SCHAKO standard for band design).

### Air throw pattern:

- blade position straight (**-L000**) (standard)
- Blade position 44° diverging (**-L044**)
- blade position 84° diverging (**-L084**)
- Blade position 110° diverging (**-L110**) (only for IB-Q-10 / IB-Q-11 / IB-Q-15 / IB-Q-16)
- Blade position 140° diverging (**-L140**) (only for IB-Q-10 / IB-Q-11 / IB-Q-15 / IB-Q-16)
- Blade position opposite to one another (**-LGEG**)

### Mounting:

- Screw mounting (**-SM**, standard)
  - screws must be provided on site
  - band design with screw mounting only
- Concealed mounting (**-VM**)
  - only available in combination with an installation frame or a plenum box
- Clamp mounting (**-KB**)
  - only available without installation frame or plenum box

### Accessories:

- Plenum box (AK-31), in rectangular design, made of galvanised sheet steel (**-SV**, standard), housing with round connection spigot and mounting brackets.
  - Length:
    - 325 mm (**-00325**)
    - 425 mm (**-00425**)
    - 525 mm (**-00525**)
    - 625 mm (**-00625**)
    - 825 mm (**-00825**)
    - 1025 mm (**-01025**)
    - 1225 mm (**-01225**)
    - length in mm, freely selectable, for band design (for a grille length BL > 1225 mm: 2-part for a length of band BL ≤ 2425 mm, multi-part for a length of band > 2425 mm) (-xxxxx, always with 5 digits).
  - Height:
    - 75 mm (**-075**)
    - 125 mm (**-125**)
    - 175 mm (**-175**)
    - 225 mm (**-225**)
    - 325 mm (**-325**)
  - Single / band design:
    - single design (standard)
    - band design (only possible for IB-Q-10 / IB-Q-11 / IB-Q-15 / IB-Q-16, for a grille length BL > 1225 mm, module length max. 1225 mm, available lengths according to SCHAKO standard for band design).
  - Mounting:
    - screw mounting (**-SM**) (standard, screws must be provided on site, band design with screw mounting only)
    - Concealed mounting (**-VM**)
  - Damper:
    - without damper (**-DK0**) (standard).
    - with damper (**-DK1**), made of galvanised sheet steel, in the plenum box housing, adjustable, for simple air volume regulation.
    - with damper (**-DK2**), same as DK1, but with cable-operated adjustment, only with spigot position from above (**-S0**) and front side spigot position (**-S4**).

- Rubber lip seal:
  - without rubber lip seal (-GD0) (standard).
  - with rubber lip seal (-GD1) made of special rubber, at the connection spigot.
- Insulation:
  - without insulation (-I0) (standard).
  - with internal insulation (-Ii), thermal insulation inside the plenum box.
  - with external insulation (-Ia), thermal insulation at the outside of the plenum box.
- Height of plenum box:
  - Standard height of plenum box (-KHS).
  - Height of plenum box in mm, freely selectable (minimum height [KHS] with spigot position S1+S2 = spigot diameter +87 mm, but at least 200 mm) (always with 3 digits).
- Spigot diameter:
  - Standard spigot diameter (-SDS).
  - Spigot diameter in mm, freely selectable (-xxx, always with 3 digits).  
(With spigot positions -S0 and -S4, if the spigot diameter is increased, only the offset plenum box shape is available)
- Spigot position:
  - Spigot from above (-S0).
  - Lateral spigot on the plenum box (-S1) (standard).
  - Front side spigot (-S4, not possible for band design).
- Installation frame (-ER0 / -ER1 / -ER2)
  - without installation frame (-ER0)
  - with installation frame made of galvanised sheet steel (only possible in the absence of a plenum box):
    - without wall anchor (-ER1)
    - with wall anchor (-ER2)