



Installation, Mounting and Maintenance

DISA-300



Ferdinand Schad KG
Steigstraße 25-27
D-78600 Kolbingen
Telephone +49 (0) 74 63 - 980 - 0
Fax +49 (0) 74 63 - 980 - 200
info@schako.de
www.schako.de

Installation, Mounting and Maintenance DISA-300

Contents

Safety instructions	3
General information	3
Warranty	3
Recycling	3
General information	4
Identification of the delivered model	4
Function	4
Installation and commissioning	5
Operating conditions	5
Material reception	5
Transport, lifting and handling	5
Storage	5
Installation	6
Mounting	6
Hydraulic connections	7
Connecting the air ducts	7
Mounting accessories	8
Adjustment of the air deflection blades	8
Checks	8
Maintenance	9
Disassembling the units	9
Air ducts and plenum box	10
Grilles	10
Registers	10
Checking the primary volumetric flow	11
Troubleshooting	12

Installation, Mounting and Maintenance DISA-300

Safety instructions

Prior to installation and commissioning of this device, please read completely through this manual. Please observe in particular the regulations and operating instructions containing the hazard symbols and safety signs. Their non-observance may result not only in damage to the device but also in light and serious personal injury.

If, after reading through the manual, you have further questions, please contact the manufacturer or the local sales office.

General information

- The inspection, installation, hydraulic connection and commissioning of the device must be carried out by qualified skilled personnel only in compliance with the current regulations.
- Electric and hydraulic connections and their correct functioning are the responsibility of the installer.
- Do not change any control or safety elements without prior approval by the manufacturer or the local sales office.

SCHAKO shall not give any warranty for damage resulting from:

- Improper use caused by ignoring the instructions given in this manual
- Non-observance of the operating conditions of the device.
- Installation and maintenance by personnel without proper qualification.
- Improper use of the device or operation under conditions not conforming to the manual.
- Use of spare parts that are not original spare parts.

Warranty

The device warranty will be for two years starting from the handover date and shall apply to all production faults. Electric components are excluded from the device warranty. However, they are covered by the corresponding warranty of the relevant manufacturer

Also excluded from the warranty is damage to the device unit caused by components that are not part of the device itself.

The warranty only covers the return and replacement of defective materials.

Recycling



It is recommended recycling the components of the device at the end of the device service life as completely as possible or use them for a different purpose.

Components that cannot be recycled must be properly disposed of by an authorized disposal company in accordance with current legal regulations.



Hazard warning



Important information



Safety information



Recycling



It is recommended keeping this manual at a safe location after installation and use it for future maintenance activities.

Installation, Mounting and Maintenance DISA-300

General information

Identification of the delivered model

The ceiling induction diffuser type DISA-300 is available in four different nozzle configurations: **A, B, C** and **D**, different device lengths and air directions (-1 or 2 supply air slots).

DISA-300-1 / DISA-300-2

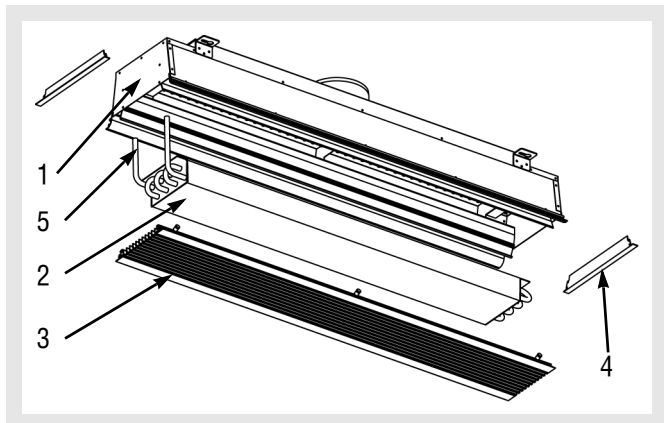

Housing (1): Galvanised sheet steel, with 1 or 2 connection pipes of DN 98, 123 (standard) and \varnothing 148 mm, horizontal (-H) or vertical (-V) position of the connection pipes.

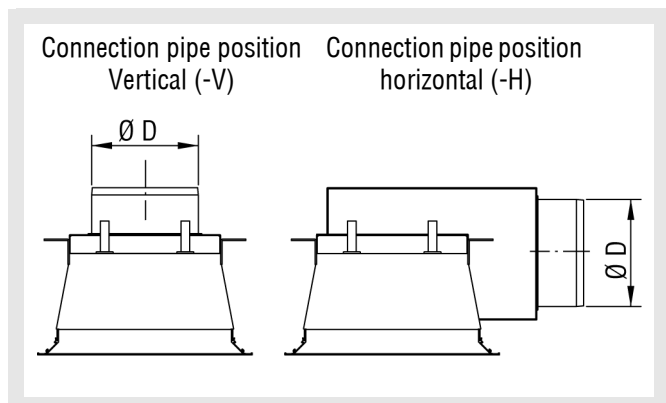

Register (2): 2-pipe (-H, standard) or 4-pipe register (-HT, optional) for cooling and heating. The registers consist of copper pipes 12 mm in thickness, aluminium ribs and a steel frame.

Grille (3): Possible designs: perforated sheet grille made of galvanised sheet steel (perforated sheet grille models: **-SR**, **-SQ**, **-RE** and **-OB**) made of extruded aluminium profile (**-PA**). Both painted to RAL 9010 (white, standard).

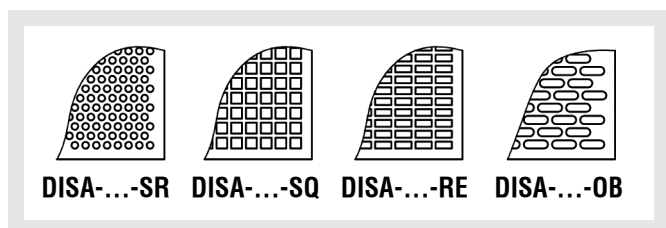

End pieces (4): Sheet steel painted to RAL 9010.

Hydraulic connections (5): Upon customer request, the hydraulic connection to the registers can be established either on the left-hand (-WS1) or right-hand side (-WS2) of the unit.

Function

The primary air (1) supplied from the plenum box induces secondary air in the room (2), which is cooled or heated via the register (3).

The primary air is mixed with the cooled secondary air. The combined (4) primary and secondary air flows are supplied to the room at low velocity via 1 or 2 supply air slots.

Schematic diagram of the mode of operation

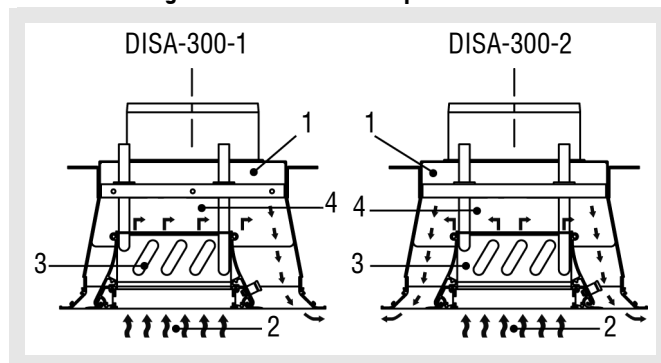

Schematic diagram of the jet path

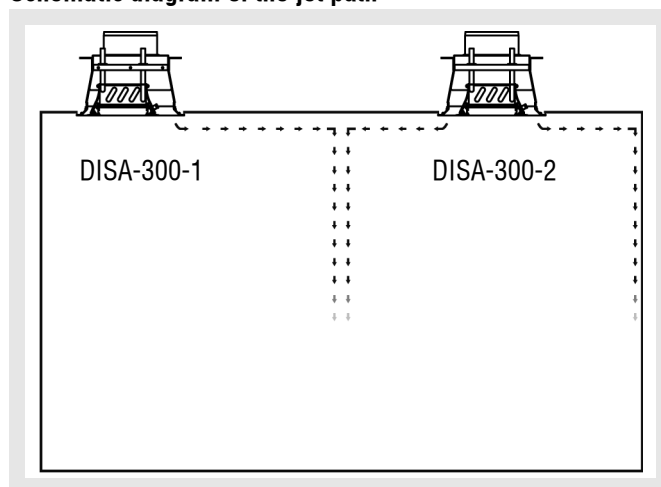

Installation, Mounting and Maintenance DISA-300

Installation and commissioning

Operating conditions

Prior to installation or commissioning of the device, the following operating conditions must be observed:

- Coolant or heating fluid: water or glycols (ethylene or propylene) at a concentration below 60%.
- Water inlet temperature: above the dew point up to 80°C (Please note that some quick-action plugs do not work at water temperatures above 65°C)
- Air inlet temperature: from 2 to 45°C
- Max. operating pressure: 8 bar / 125°C









To prevent deposits and corrosion, the quality of the water for filling the registers must comply with regulations VDI 2035 and DIN 50930.

Material reception

Upon reception of the materials, the components must be carefully checked, in order to guarantee that no transport damage has taken place. Moreover, the dimensions, composition and number of the identification sticker must be checked as to whether they are as ordered.

Identification sticker:

 	
Model / Modelo / Modell DISA-300/2/H/OL/SR/A/298/900/1200/M/WS1/H/AS1/123/2E	
Order nr. / N° Pedido / Auftragsnr.:	2198/09
Date / Fecha / Datum:	22/10/2009
Reference / Referencia / Referenz:	Sala 1 Hospital Clínico
Comments / Observaciones / Bemerkungen:	
 Read manual of instructions / Lea el manual de instrucciones / Betriebs- und Wartungsvorschriften beachten.  Do not drill the machine / Maschine nicht durchbohren / No taladrar la máquina  Special attention in the connection nuts-coil / Besondere Vorsicht an der Registerverschraubung/ Especial cuidado en la conexión tuercas-batería .  Recycle or arrange the residues according to the current rules / Recicle o gestione los residuos según la normativa vigente. Bitte, entsprechend der gültigen Gesetzgebung recyceln.	

- **2:** Number of supply air slots - 2 supply air slots -
- **H:** 2-pipe system
- **OL:** Without air deflection blades
- **SR:** Foldable perforated sheet, - perforation Ø 6 mm -
- **A:** Nozzle configuration - A -
- **298:** Width -298 mm-
- **900:** Nominal length - 900 mm -
- **1200:** Total length -1200 mm-
- **M:** Housing position - centre -
- **WS1:** Hydraulic connection - left -
- **H:** Connection - horizontal -
- **AS1:** Number of connection pipes - 1 connection pipe arranged
- **123:** Diameter of the connection pipes - 123 mm -
- **2E:** Model with two end pieces

To prevent possible damage during transport, the devices will be delivered ex works on pallets (that correspond to the particular weight and dimensions) wrapped with tapes and transparent plastic film. It is recommended leaving this protection in place until the device is commissioned. The openings of the pipes should be closed with dust caps to avoid dust and entry of dirt.



Should manufacture-related damage be detected on the device, please contact your local sales office prior to installation.

Transport, lifting and handling

Transport and handling of the unit shall take place in the position in which the unit is to be built in later on, unless expressly stated otherwise on the unit.

Transport, unloading and lifting of the unit shall take place with the necessary care and using tools that are appropriate for the weight and dimensions.

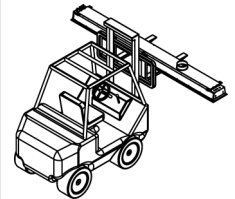

NL	900	1200	1500	1800	2100	2400	2700	3000
Weights⁽¹⁾ (kg)	13	17	20	24	27	31	34	38

⁽¹⁾ Standard unit: housing + slot + grille and heat exchanger (empty)



The unit shall only be held in position or moved by holding on to the housing. The weight must not rest on the water connections.



SCHAKO cannot be held liable for damage to the unit caused by improper handling or handling not mentioned here, loading or unloading.

Storage

If the device is not installed immediately after its reception, it must be stored according to the following instructions:

- The device must be stored at a dry, clean, safe location where no damage to the device can occur, i.e., outside corrosive atmospheric influences.
- Leave the protections attached ex works (film, tapes, pallets, etc.) on the device, unless they have already been removed beforehand.
- Cover the device with tarpaulins, in order to protect it from dust, moisture and extreme temperatures.
- Entries, openings and pipes must be hermetically sealed with dust caps.

Installation, Mounting and Maintenance DISA-300

Installation

The ceiling induction diffuser type DISA-300 is particularly suitable for horizontal installation in low false ceiling heights. The devices must not be installed in places with extreme moisture (e.g. laundries or swimming pools), with high dust formation, outdoors or in places subject to explosion hazards.

For correct installation, the following instructions must be followed:

- Make sure that places that are intended as openings for air admission and air discharge are free of pipes, electric cables, crossbeams, stands, etc.
- Install the unit at a site that has good air quality.
- Make sure that wall and ceiling correspond to the weight of the device and also allow correct mounting of the fastening elements in the ceiling.
- The installation site must have sufficient space and the necessary resources for carrying out mounting and maintenance activities of all device components. Make sure that the valves are easily accessible.
- The hydraulic pipes should be attached above the device.

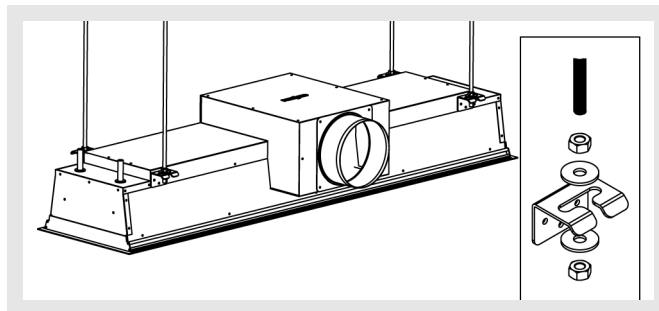

For the installation of the device, use adequate tools, devices and materials and observe the safety regulations and other current regulations.



SCHAKO cannot be held liable for damage resulting from faulty installation or the use of unsuitable fastening devices.

Mounting

The induction diffusers are mounted to a load-bearing ceiling construction using threaded bars, nuts and an M8 washer.

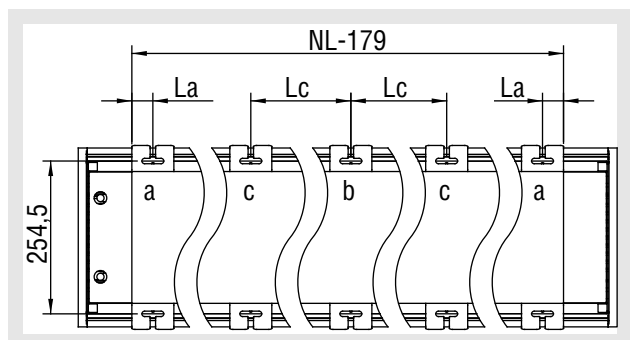

NL (mm)	La (mm)	Lc (mm)	V	H	
				1 connecting piece	2 connecting pieces
900	25	-	a	a	a
1200		-	a	a	a
1500		-	a	a	a
1800		-	a	a	a
2100		234	a,b	a,c	a,b
2400		217	a,b	a,c	a,b
2700		206	a,b	a,c	a,b
3000		198	a,b	a,c	a,b

During mounting the end of the register pipes must be sealed to protect them from dust and dirt.

Band design

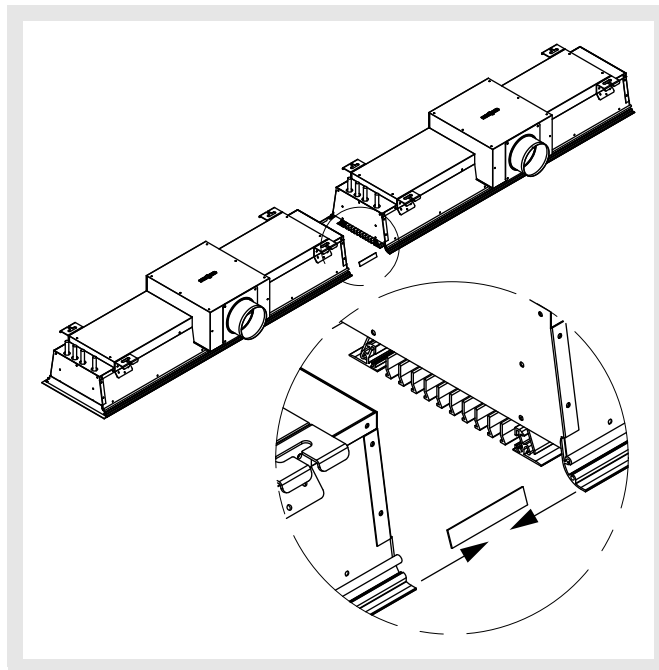

- Aligning the devices
- Inserting and approaching the connection elements between the profiles
- The connection parts are delivered with the device

Installation, Mounting and Maintenance DISA-300

Hydraulic connections

Upon customer request, the hydraulic connection to the registers can be established either on the left-hand (-WS1) or right-hand side (-WS2) of the unit.

DISA-300-1-...-WS1

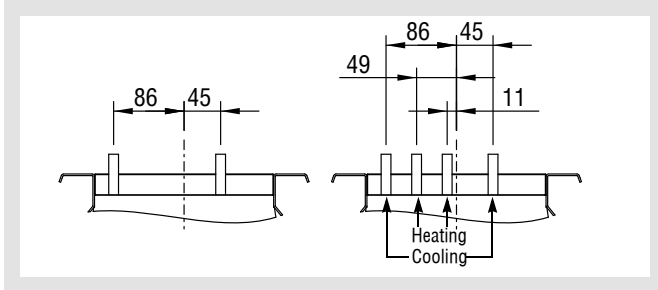

DISA-300-1-...-WS2

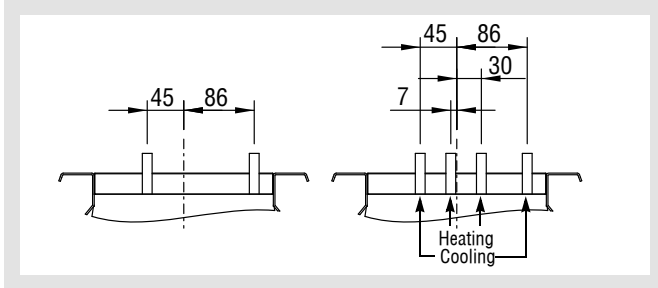

DISA-300-2-...-

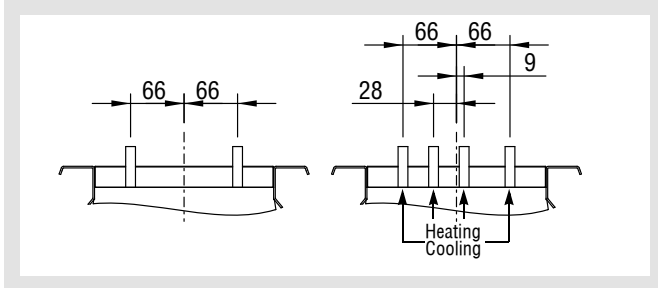

Amount of water of the registers:

NL	Water capacity (litres)		DISA-300-...-H
	DISA-300-...-HT Heating	DISA-300-...-HT Cooling	
900	0,2	0,6	0,8
1200	0,3	0,8	1
1500	0,3	1	1,3
1800	0,4	1,2	1,6
2100	0,5	1,4	1,8
2400	0,5	1,6	2,1
2700	0,6	1,8	2,4
3000	0,7	2	2,7

The connection of the hydraulic connections can be done by soldering, pressing (in connection with supporting sleeves) or by means of flexible hoses resistant to oxygen diffusion and push-fit systems. The use of flexible hoses is subject to the manufacturer's specification.

When making the hydraulic connections, you have to use suitable tools to avoid excessive tightening or twisting of the register connections.

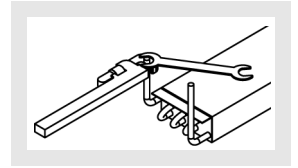

- ⚠ In order to achieve a uniform cooling capacity, the ceiling induction diffusers type DISA-300 should be connected to the cold water distribution system in parallel.
- ⚠ The ceiling induction diffusers type DISA-300 are induction devices for "dry cooling". To avoid condensates, the water inlet temperature should be higher than the dew point.

When charging the register, make sure by means of on-site ventilation devices that no air remains in the hydraulic circuit. If the unit is to be installed at a location having temperatures below zero degrees, glycol must be admixed to the coolant in a suitable ratio, to ensure that the freezing point of this liquid always stays below the minimum temperature of the operating site. Please note that the use of an antifreeze necessarily results in a loss in performance of the register.

Connecting the air ducts

The air ducts are attached by using pipe clamps, fixing lugs or the like.

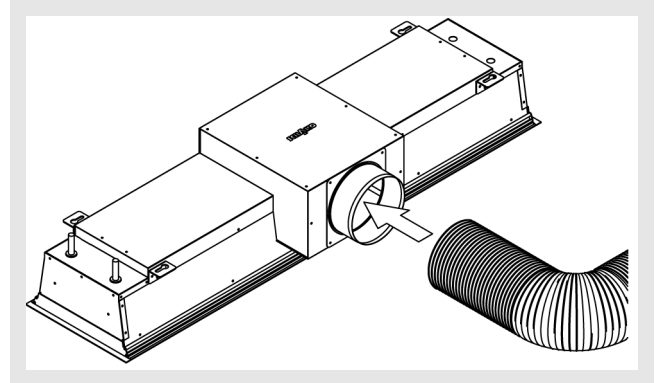

Optionally, a rubber lip seal can be installed on the connection pipe, to ensure tightness between the device and the pipes.

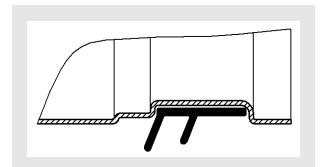

Installation, Mounting and Maintenance DISA-300

Mounting accessories

Valves and actuators

Valves and actuators shall not be installed ex works. During installation the manufacturer's specifications must be observed.

Temperature controls

The temperature controls are mounted in accordance with the selected model. This is why the instructions enclosed with each model must be followed. However, in order to achieve optimum measurement by the sensors, the following basic information should be observed:

- Do not mount the temperature control close to or above a heat source (direct sunlight, lamps, television sets, radiators, etc.), in places with draught air or directly opposite to an air diffuser grille.

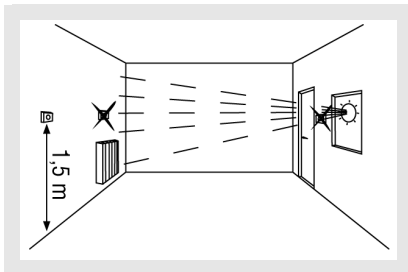

- Temperature controls must be mounted at least 1.5 metres above the floor.
- Mounting temperature controls on walls toward the outdoors should be avoided.

 Prior to drilling, make sure that at the location in the wall where the temperature control is attached no electric cables are present.

Condensate monitor

The installation of a condensate monitor depends on the selected model. Please follow the instructions enclosed with each model.

 Faulty mounting of the sub-assemblies and of the accessories of the unit can result in a substantial power loss of the unit.

Adjustment of the air deflection blades

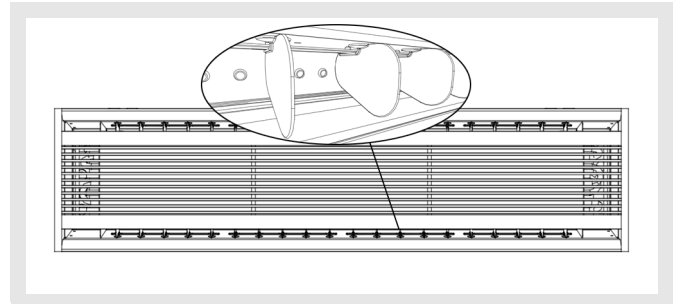

To regulate the air flow, rotate the air deflection blades manually.

With blockwise adjustable blades, 5 blades can be adjusted simultaneously.

 The adjusting angle of the air deflection blades must not be more than $\pm 45^\circ$, in order to guarantee its function.

 At an adjusting angle of the air deflection blades outside the straight air throw of up to 45° , the cooling capacity of the heat exchanger is reduced by up to 5%, and the horizontal throw is reduced.

Checks

Prior to commissioning, the following items must be checked or guaranteed:

- Hydraulic connections were tightened properly and exhibit no leaks.
- Connecting and fastening elements have been sufficiently tightened.
- Adequate access for carrying out the maintenance activities has been provided.
- Use the on-site ventilation devices to ensure that no air remains in the register and the water circuit.

 After carrying out the items described above, the correct fastening of the unit must be checked.

During commissioning itself, the following items must be guaranteed:

- The connecting and fastening elements have been sufficiently tightened.
- In heating mode, the temperature of the discharged supply air is not above 40°C .

Installation, Mounting and Maintenance DISA-300

Maintenance

For reasons of safety, the power supply and hydraulic circuit must be disconnected prior to any maintenance activity. If the unit was operated in heating mode, you have to wait until the register has cooled down.



When performing maintenance activities, it is recommended wearing personal protective equipment, in order to avoid cuts and other injuries produced by sharp and pointed parts.

Disassembling the units

The entire DISA-300 is equipped with a series of safety locks which allow the grille to be folded down via a rotating mechanism on one of the profiles for safe execution of maintenance. The unit is dismantled as follows:

- Open the safety locks.
- Fold the grille down and remove it.
- This makes the grille and the registers freely accessible for cleaning purposes.
- After completing the maintenance activity, you must move the grille again to its original operating position and then close the safety locks again.

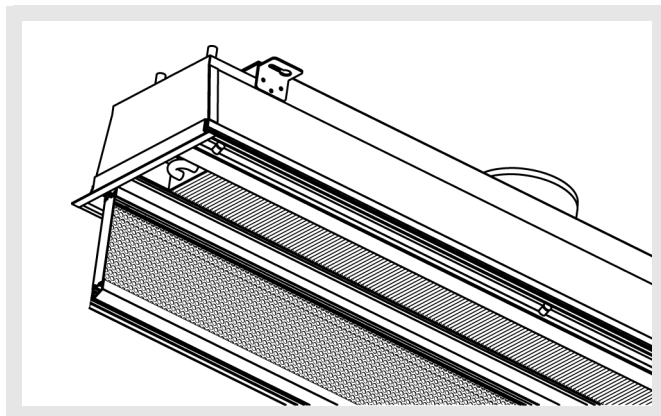
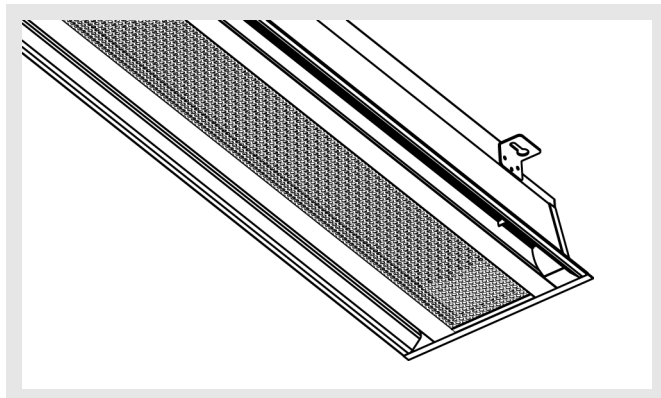

DISA-300-1-H

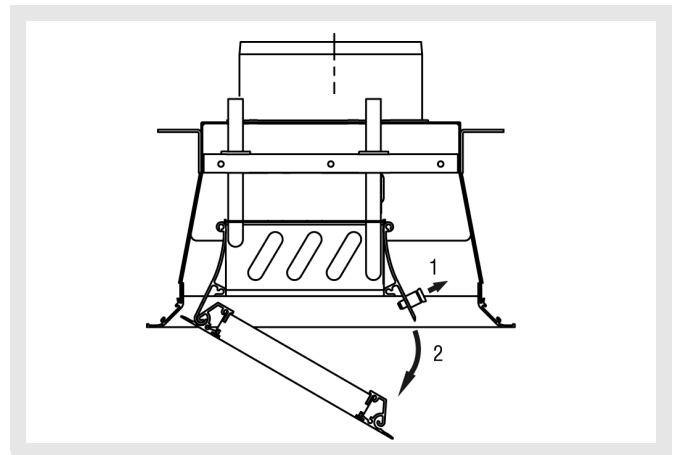
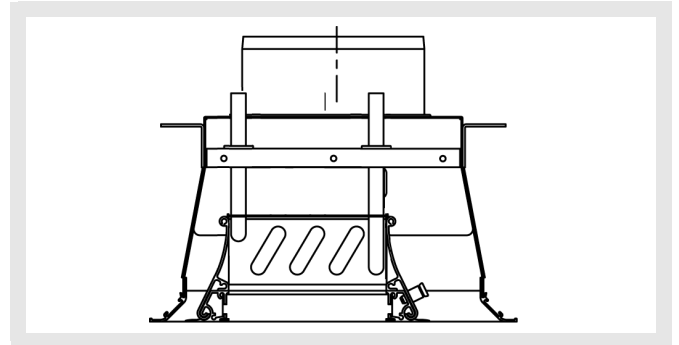

DISA-300-2-H

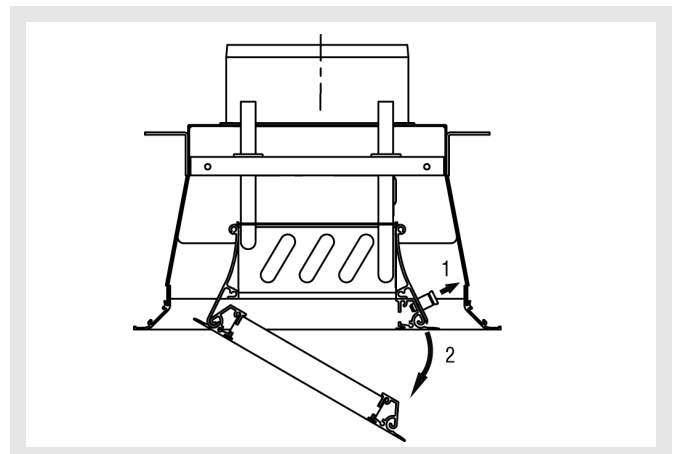
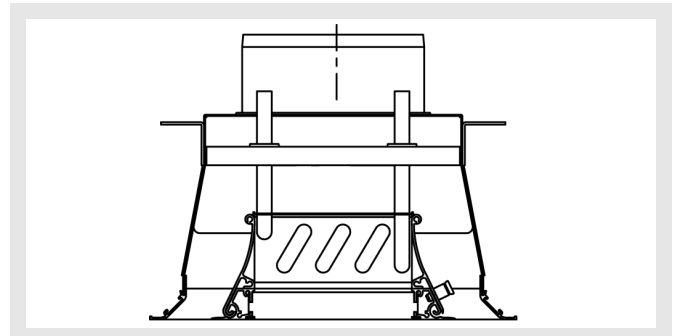

Installation, Mounting and Maintenance DISA-300



To avoid accidental rotation or folding down of the grille, please check that the locks are properly closed.



For reasons of safety, the power supply and hydraulic circuit must be disconnected prior to any maintenance activity.

Air ducts and plenum box

Clean them by blowing compressed air through them or using non-aggressive cleaners.

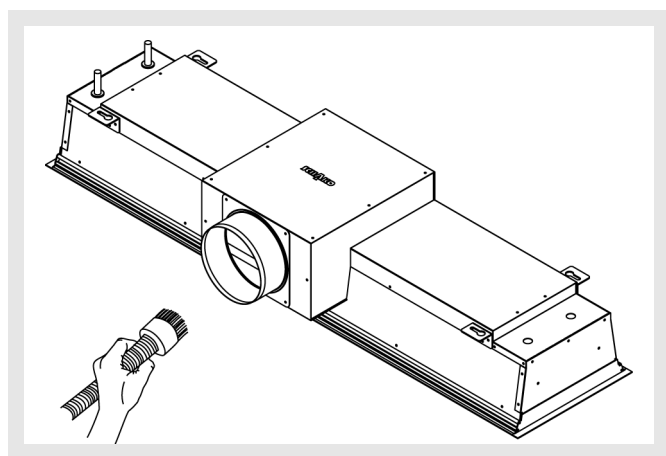

Grilles

Clean them by blowing compressed air through them or using non-aggressive cleaners.

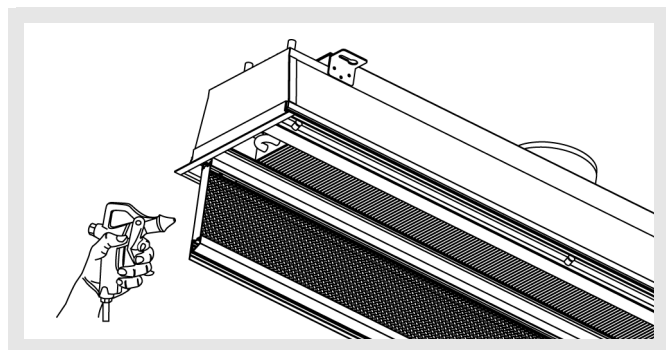

Registers

To guarantee the technical characteristics of the device, the registers and heat exchangers must be kept in good clean condition. To ensure this, the following maintenance activities must be carried out:

- If the register is dirty, clean it by spraying it with water or compressed air or by evacuation.
- Please do not use any scouring agents for cleaning since these materials may impair or damage the DISA-300 (galvanised steel, aluminium and copper) and the surface coatings (paints and anodised surfaces).
- If there are larger differences in distance between the ribs, they must be "combed".
- Ventilate the hydraulic circuits of the register. In doing so, watch out for possible leaks of the hydraulic system.

If condensates are detected, interrupt the hydraulic circuit and find the possible cause of the problem.



When decommissioning the unit or shutting it down for a longer period in winter, the water must be drained from the unit, in order to avoid damage to the register due to the formation of ice. If you want to use antifreezes, you must first determine the freezing point.



After recharging the register, the installer has to make sure by means of on-site ventilation devices that no air remains in the hydraulic circuit.

Installation, Mounting and Maintenance DISA-300

Checking the primary volumetric flow

The supplied primary volumetric flow can be simply checked by checking the static pressure with a Pa meter and the measuring tube available from us as accessory.

To this end, one end of the measuring tube fitted with a rubber cap is pressed against the air outlet of one of the nozzles at the primary air plenum box (see drawing) and the other end is connected to the hose connection of a Pa meter.

The values read on the meter and the following formula can be used to determine the volumetric flow:

$$V = K\sqrt{P_s}$$

V [l/s] = Primary air flow

Ps [Pa] = Static pressure

The K value is taken from the following table:

Nozzle configuration	NL (mm)							
	900	1200	1500	1800	2100	2400	2700	3000
A	0,42	0,62	0,79	0,99	1,16	1,32	1,51	1,69
B	0,71	1,06	1,35	1,69	1,98	2,27	2,59	2,90
C	1,32	1,96	2,50	3,14	3,68	4,21	4,80	5,39
D	1,97	2,92	3,72	4,67	5,48	6,28	7,15	8,03



The Pa meter is not included in the delivery.

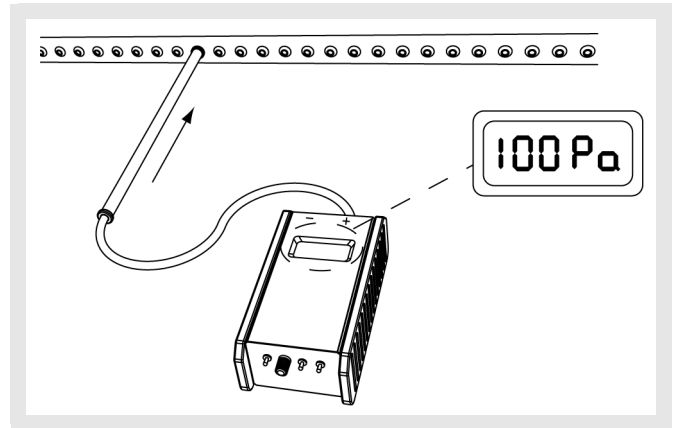

Nozzle configuration A

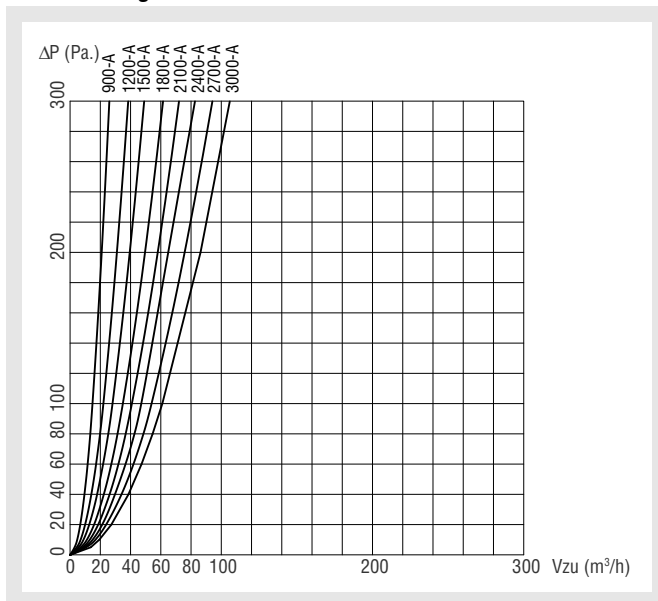

Nozzle configuration B

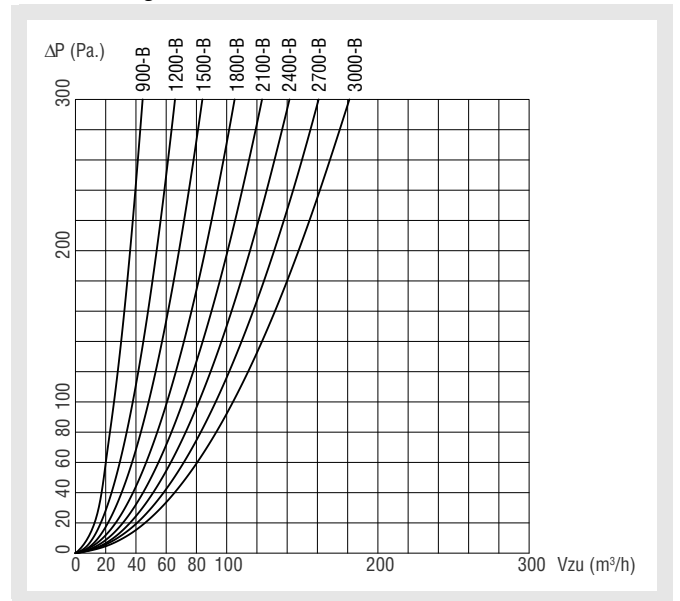

Installation, Mounting and Maintenance DISA-300

Nozzle configuration C

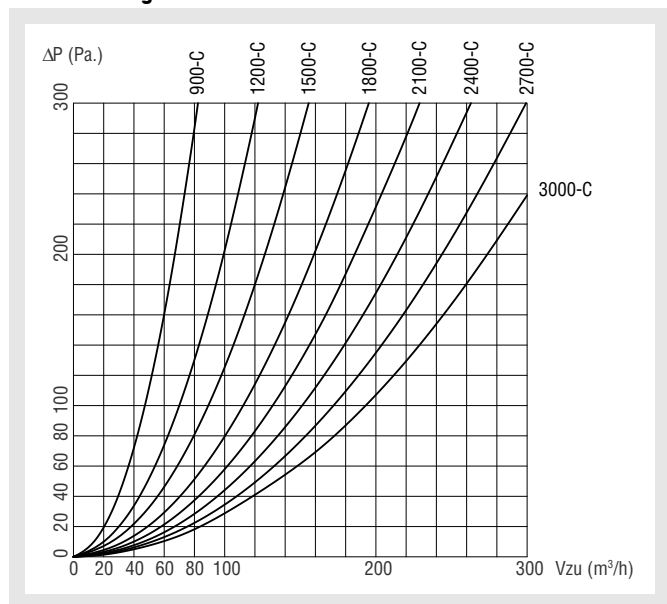

Nozzle configuration D

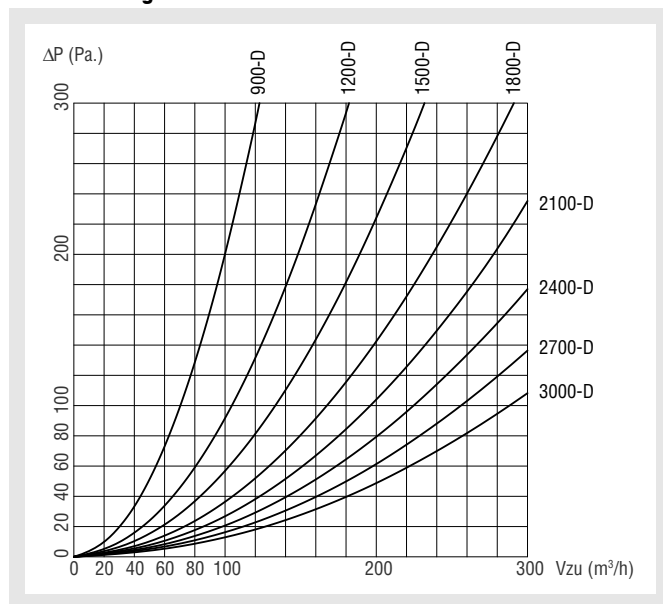

Troubleshooting

Problem	Possible cause	Solution
The unit does not cool or heat sufficiently	Air inlet and outlet of the inner unit clogged	Remove foreign material and clean the unit
	Air in the interior of the register	Ventilation of the hydraulic system Please inform the installer
	Installed unfavourable or malfunctions at the temperature control or sensor	Install thermostat in a different place
	Clogging in the interior of the unit or at the air inlet	Remove foreign material and clean the interior of the unit
The unit is losing water	Condensate in the register	Modify the register water inlet temperature
	The water circuit of the register is leaking	Please inform the installer
	Register damaged	
	Incorrect valve or hydraulic connection	
The unit is working with too much noise	The air intake or air blow openings or the lines are clogged.	Remove foreign material and clean the unit
	Loose screws and fastening elements	Tighten screws
	Foreign material or dirt on register surface	Remove foreign material by careful brushing