

Pure competence in air.

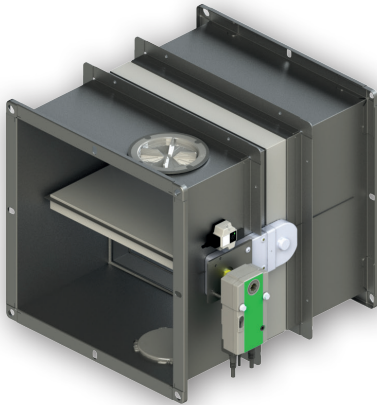

BKE

Fire damper

The SCHAKO BKE fire damper is a systematic, innovative new development into which our decades of experience and practical expertise have flowed. The BKE is characterised by the largest possible free cross-sections and enclosed drive unit located on the exterior.

Technical features

- Installation options in wood structures
- One-piece housing for increasing the housing tightness as per DIN EN 1751.
- Enclosure of the drive unit, the thermal trigger device, including the temperature-sensitive sensor for economical and sustainable operation.
- Easy conversion/retrofitting to spring return actuators from the outside is possible, even if a fire damper is already installed.
- Can be combined with the SCHAKO EasyBus signaling and switching bus system
- Hygiene certificate
- Environmental product declaration (EPD)
- ATEX mark

Available sizes

W x H = 200 x 100 mm to 1,500 x 800 mm.

Intermediate sizes in a 5 mm grid are also possible.

Technical changes reserved.

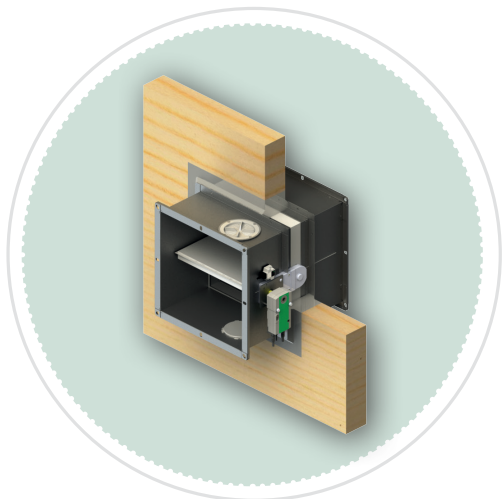

Installed in a cross-laminated timber wall (CLT), wet installation

Areas of application

BKE – The fire damper for wood structures

Wood is a sustainable and renewable raw material which impresses primarily thanks to its positive and healthy properties. The fact that it also binds large amounts of CO₂ is another advantage.

This is why wood is increasingly being used as a building material, including in walls and ceilings for complete building structures.

The SCHAKO BKE fire damper is used with wood-frame, wood-panel and timber-frame walls, as well as cross-laminated timber walls and ceilings (CLT structures) and in both wet and dry installation.

Accessories

- Installation frame for dry installation

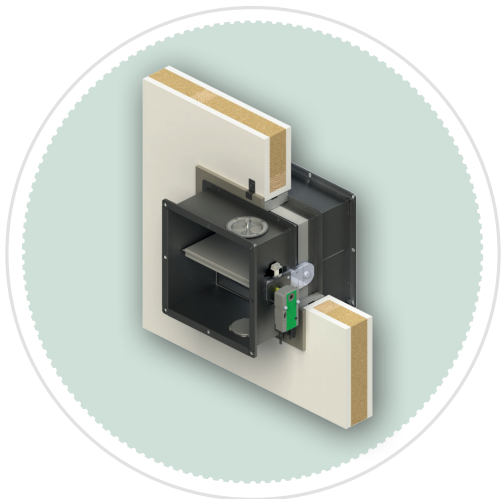

Installed in a wood-frame wall, dry installation with mounting frame

Function

Safe and reliable

The increasing need for safety by people in modern and complex buildings continually requires new, refined and reliable solutions.

The EU Construction Products Regulation defines seven basic requirements for buildings in order to be used safely. Fire protection comes right in at second place due to its central importance. The SCHAKO BKE meets all requirements without exception.

Installed in the ventilation lines of room ventilation systems, the fire damper is automatically activated in the event of an emergency starting from a temperature of 72° Celsius.

The BKE conforms to harmonised product standard EN 15650. Classification up to EI 120-S is carried out as per EN 13501-3. The BKE is tested as per EN 1366-2.

Benefits

- Used in buildings with wood structures
- Used to meet the requirements of VDI 6022 for the protection of people's health
- Positive effect on the building verification process according to the DGNB and LEED systems
- Used in areas subject to explosion hazards

Performance values

- Minimal pressure loss thanks to an increase in free cross-sections with certain design sizes.
- Reduction in sound power level thanks to minimised installation parts in the air flow.

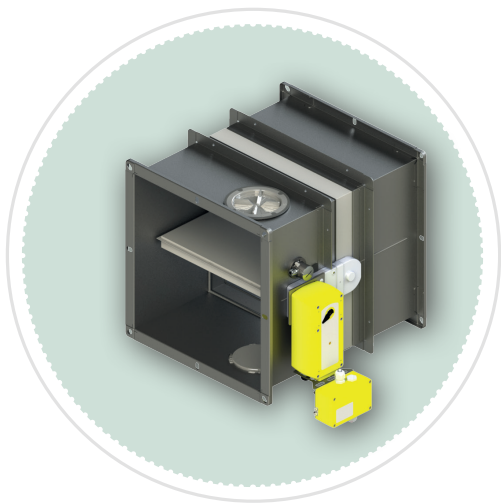

SCHAKO stands for competence in ventilation and air conditioning technology. The quality standard and reliability of our products are well known throughout Europe. At our own test laboratories, we develop solutions which sustainably optimise the indoor climate in work environments and public spaces. With sites in Germany, Spain and Hungary, we deliver quickly and flexibly throughout Europe.

We carry a wide standard range and are ideally positioned to meet special air demands with individual and smart solutions as well.

Pure competence in air.

As specialists, the companies of **SCHAKO Group – ADMECO, NOVENCO Building & Industry, REVEN, SCHAKO, SCHNEIDER Elektronik, SIROCCO and SMITSAIR –** offer a unique portfolio of ventilation, air conditioning, smoke extraction & fire protection products and system solutions for operating theatres, commercial construction, public buildings, canteen kitchens, laboratories, the process industry, stairwells, underground car parks, tunnel systems and data centres.

SCHAKO KG

Steigstrasse 25-27
D-78600 Kolbingen
Germany
schako.com

Version: 2023-02-28

