

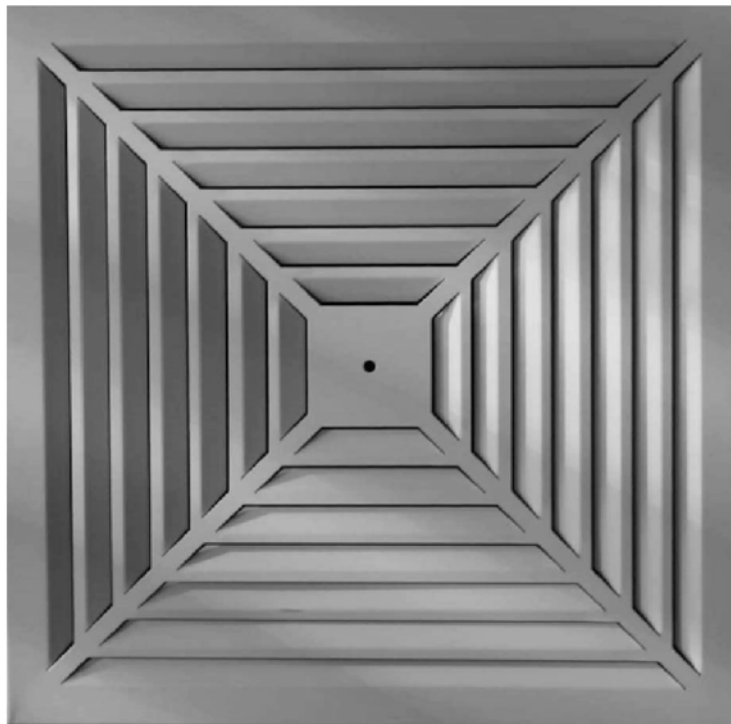

Ceiling diffuser

4DF



SCHAKO KG
Steigstraße 25-27
D-78600 Kolbingen
Telephone +49 (0) 74 63 - 980 - 0
Fax +49 (0) 74 63 - 980 - 200
info@schako.de
schako.com

Ceiling diffuser 4DF

Contents

Description	3
Construction	3
Model	3
Accessories	3
Fastening	3
Models and dimensions	4
Dimensions	4
Dimensions of accessories	5
Technical data	6
Pressure loss and noise level	6
Supply air with plenum box	6
Return air with plenum box	7
Maximum end velocity of jet	8
Critical throw	9
Induction ratios	10
Temperature ratios.....	10
Legend	10
Order details 4DF	11
Order details SK	12
Specification texts	13

Ceiling diffuser 4DF

Description

The **square** ceiling diffuser type 4DF with **fixed air deflection blades** is suitable for use **in supply and return air systems**. The supply air is **delivered horizontally in four directions**. The air diffuser is fitted flush to the ceiling. The construction of the faceplate allows easy cleaning.

A volumetric flow meter can be integrated into the spigot of the plenum box at an extra charge. The measurement error of the volumetric flow meter is $\pm 5\%$ at a connection spigot velocity of 2-5 m/s and a straight flow pattern of at least $1 \times D$. The measurement is carried out with mounted diffuser. By adjusting the throttle damper, the required air volume of each diffuser can be set quickly and correctly.

The damper, equalising grid and volume flow measuring device can easily be removed from the plenum type SK-Q-... model for easy cleaning from the room side.

Variable volumetric flow

The ceiling diffuser type 4DE is also highly suitable for systems with variable volumetric flows. A stable air jet is guaranteed by the high exit velocities thus ensuring no air dumping.

Construction

Faceplate

- Sheet steel painted to RAL 9010 (white)
- Sheet steel painted to a different RAL colour (at an extra charge)

Model

- | | |
|-----------|--------------------|
| 4DF | - square faceplate |
| 4DF-Z-... | - Supply air |
| 4DF-A-... | - return air |

Accessories

Plenum box (SK-Q-07-...)

- Galvanised sheet steel with integrated perforated straightener (for supply air model only) and fixing lugs
- only available in conjunction with concealed mounting

Damper (-DK1)

- Galvanised sheet steel, in plenum box (SK-Q-...)
- Damper fastening made of plastic

Damper (-DK2)

- same as -DK1, but with cable-operated adjustment

Rubber lip seal (-GD1)

- at the plenum box connection spigot, made of special rubber

ROB version (-ROB1)

- Removable diffuser plate, damper and volumetric flow meter

Volumetric flow meter (-VME1)

- Holder made of galvanised sheet steel
- Measuring sensor made of plastic
- Aluminium connections

Internal insulation (-li)

- thermal insulation at the inside of the plenum box

External insulation (-la)

- thermal insulation at the outside of the plenum box

Fastening

Concealed mounting (-VM, standard)

- Only possible in connection with plenum box SK-Q-...
- fastened to the plenum box type by means of an M6 screw to DIN EN ISO 10642.

Ceiling diffuser 4DF

Models and dimensions

Dimensions

4DF with SK-Q-07-Z-... (for supply air, with concealed mounting)

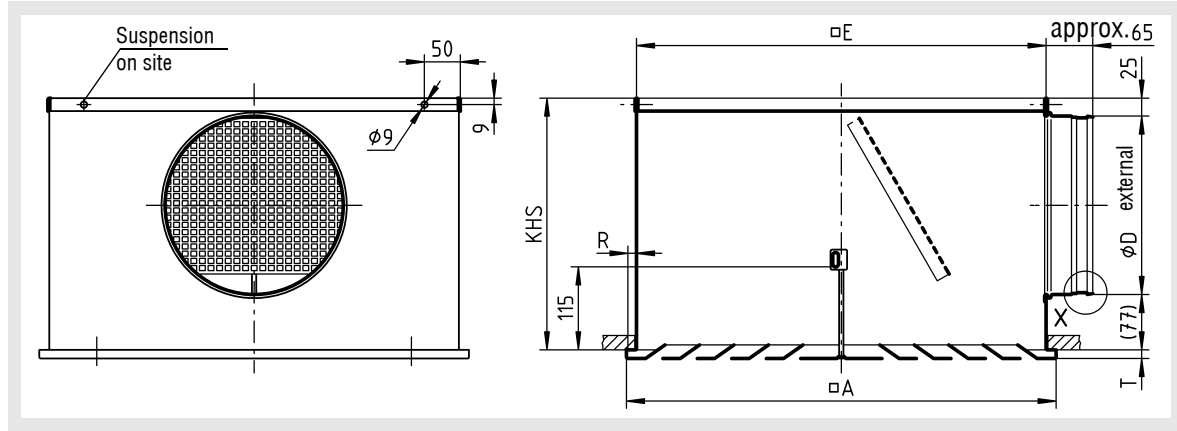

4DF with SK-Q-07-A-... (for return air, with concealed mounting)

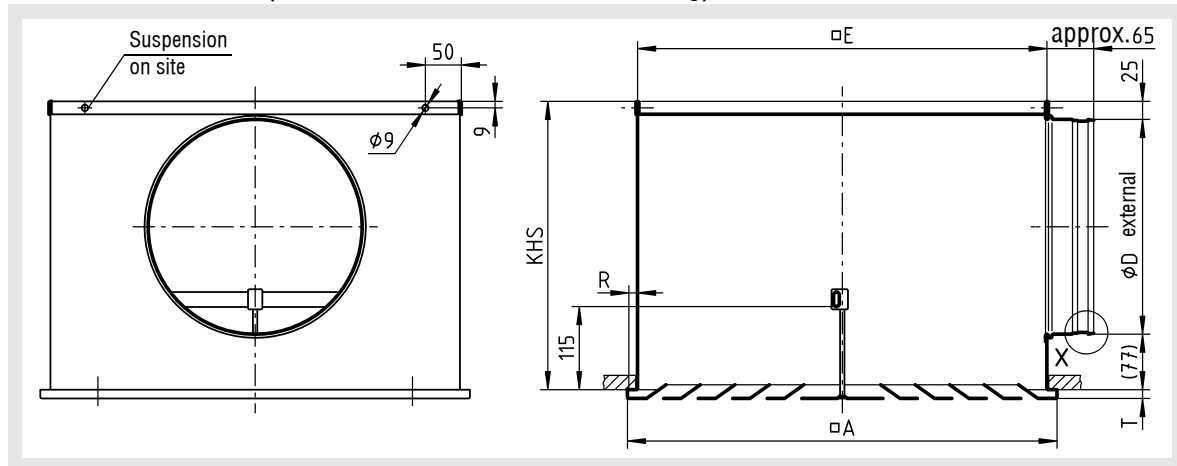

Available sizes

NW	A	E	R	SK-Q-07-Z-...		SK-Q-07-A-...		T	øD _{max} for ...-S5
				KHS	øD	KHS	øD		
310	308	290	8	260	158	300	198	7	98
400	398	370	12	260	158	300	198	12	138
500	498	470	12	300	198	350	248		198
600	598	570	12	350	248	400	298		248
625	623	570	24	350	248	400	298		248

KHS= standard height of plenum box
 Special height of plenum box = $\text{øD} + 102\text{mm}$,
 but at least 200mm
 Note: For SK-Q-07-Z-...-DK1/-DK2-...-S0, the
 height of plenum box changes to KHS=280 mm
 for NW310 and NW400 (see p. 5)

Spigot position

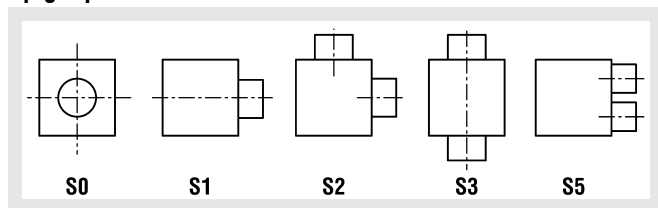

Ceiling diffuser 4DF

Accessories - dimensions

(at an extra charge):

Volumetric flow meter (-VME1)

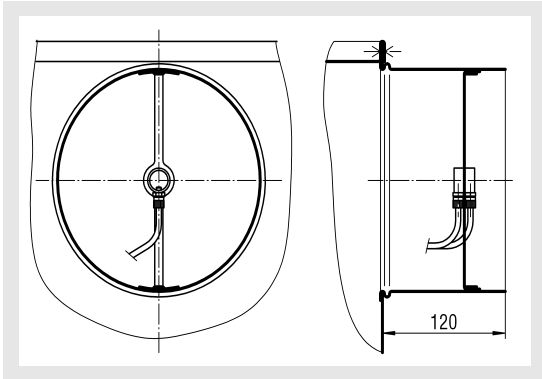

Insulation for SK-Q-...

internal (-li)

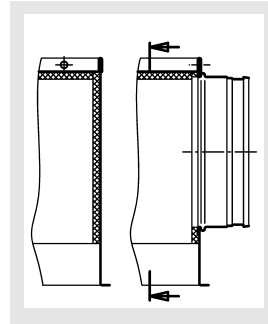

outside(-la)

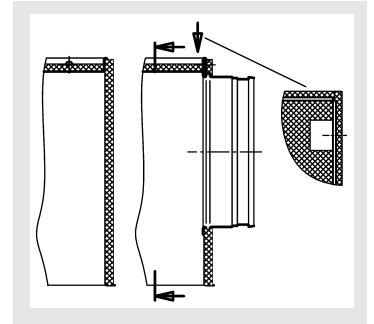

Damper (-DK1/-DK2)

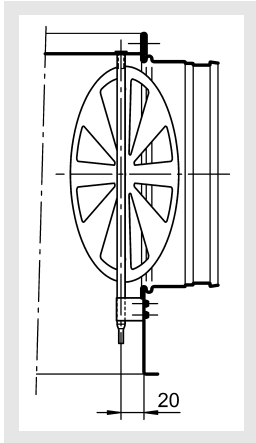

DK1 = without cable-operated adjustment

DK2 = with cable-operated adjustment

Height of plenum box with spigot from above (-S0)

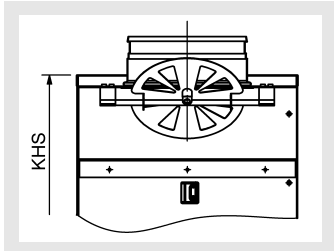

For the model with spigot from above (-S0) in combination with damper (-DK1 / -DK2), the height of box KHS changes for the following NW as follows.

NW	SK-Q-07-Z-...	
	KHS	øD
310	280	158
400	280	158

Rubber lip seal (-GD1)

Detail X

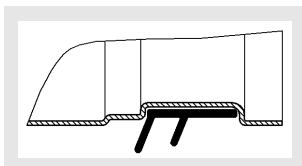

Ceiling diffuser 4DF

Technical data

Pressure loss and noise level

Supply air with plenum box

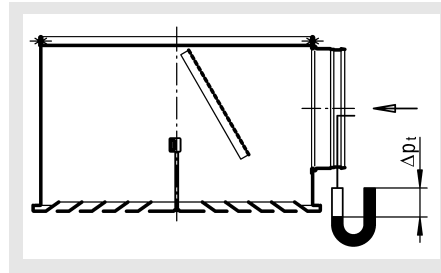

Damper position OPEN in %

4DF-Z-310-... with SK-Q-07-Z-...

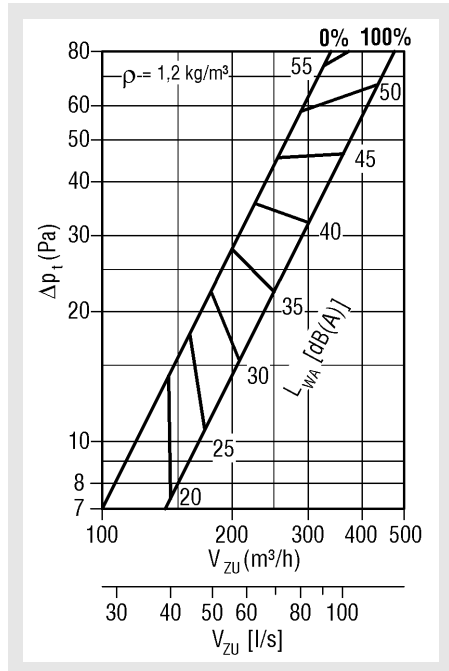

4DF-Z-500-... with SK-Q-07-Z-...

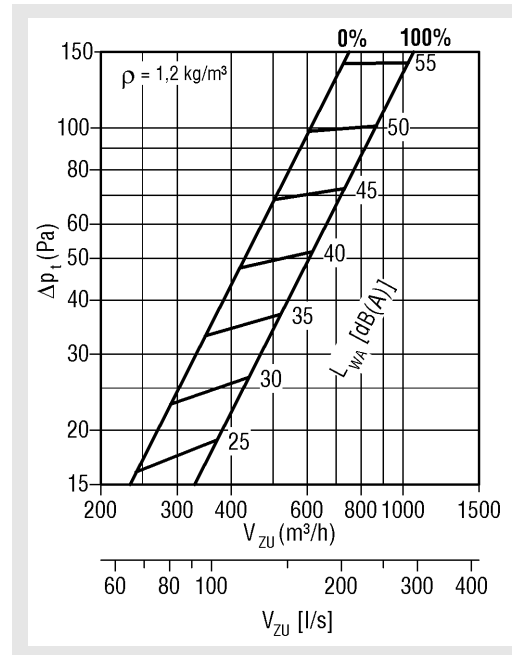

4DF-Z-400-... with SK-Q-07-Z-...

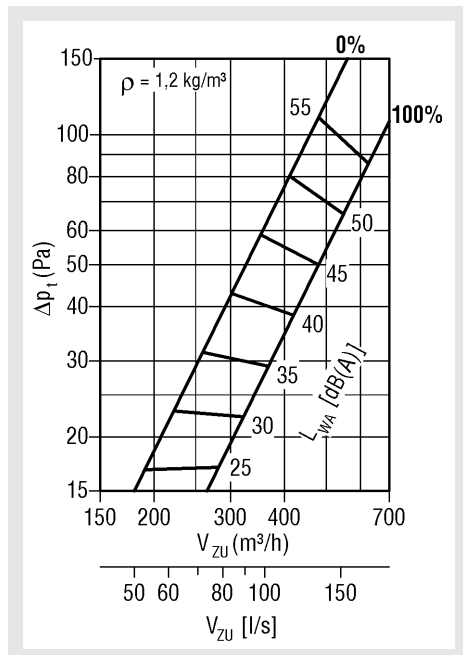

4DF-Z-600/625-... with SK-Q-07-Z-...

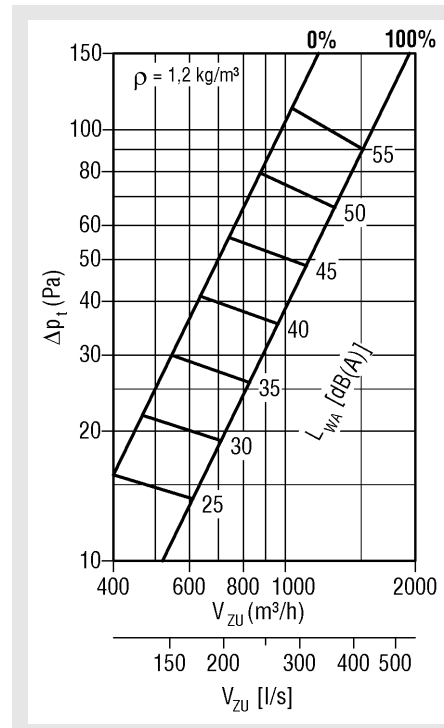

Ceiling diffuser 4DF

Return air with plenum box

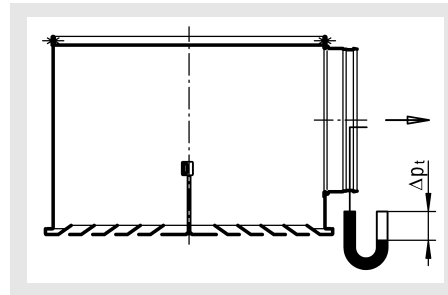

Damper position OPEN in %

4DF-A-310-... with SK-Q-07-A-...

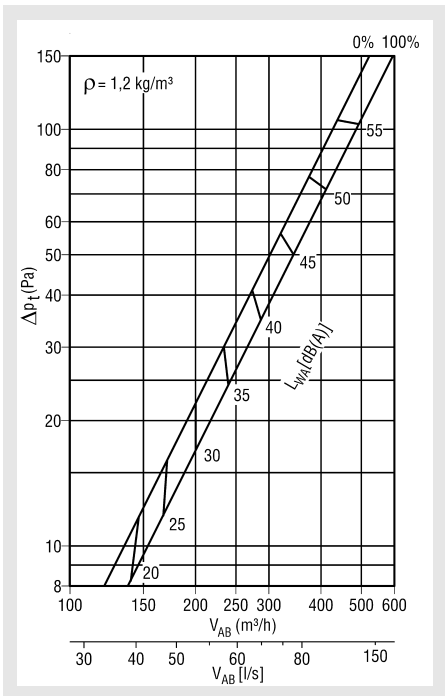

4DF-A-500-... with SK-Q-07-A-...

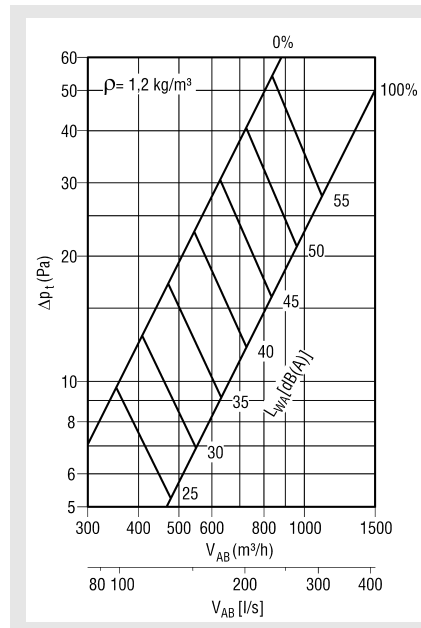

4DF-A-400-... with SK-Q-07-A-...

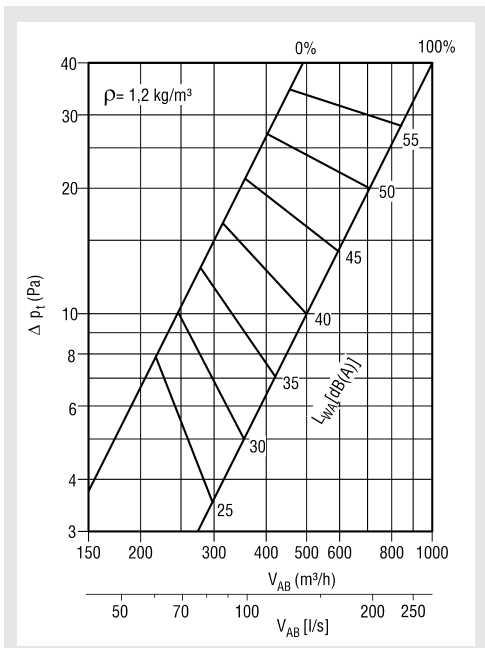

4DF-A-600/625-... with SK-Q-07-A-...

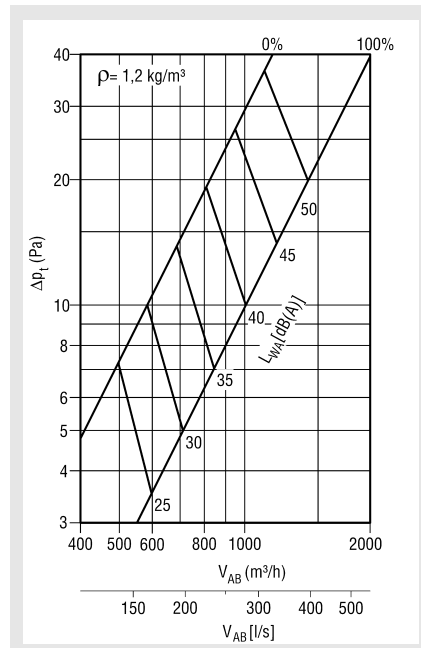

Ceiling diffuser 4DF

Maximum end velocity of jet
with plenum box
4DF-Z-400-...

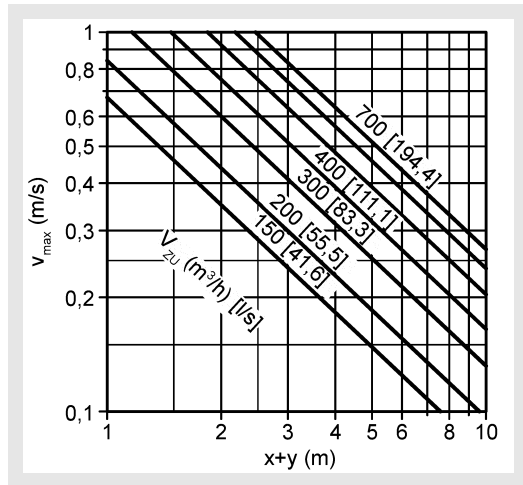

4DF-Z-500-...

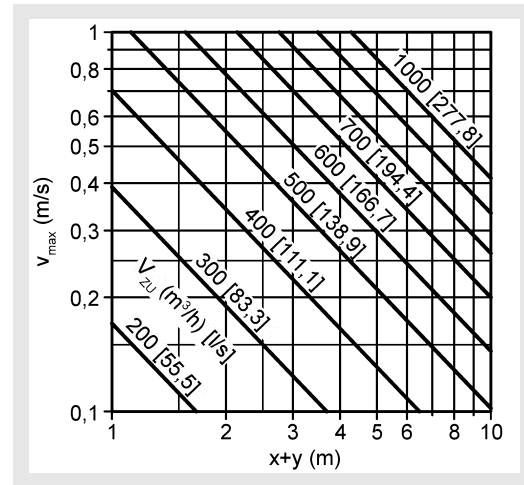

4DF-Z-600/625-...

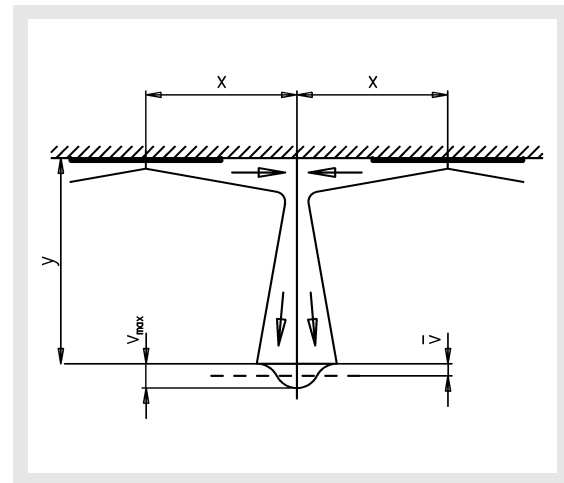
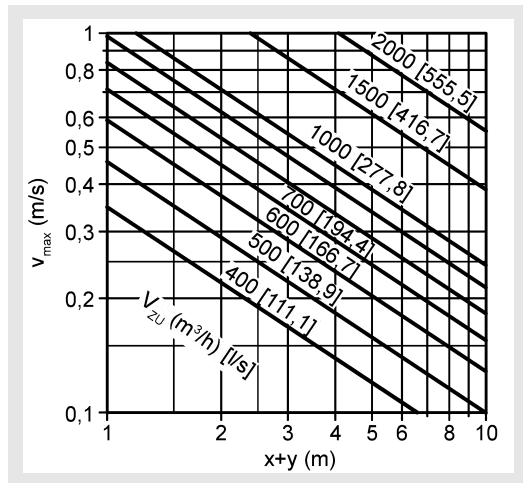

Ceiling diffuser 4DF

Critical throw

4DF-Z-400-...

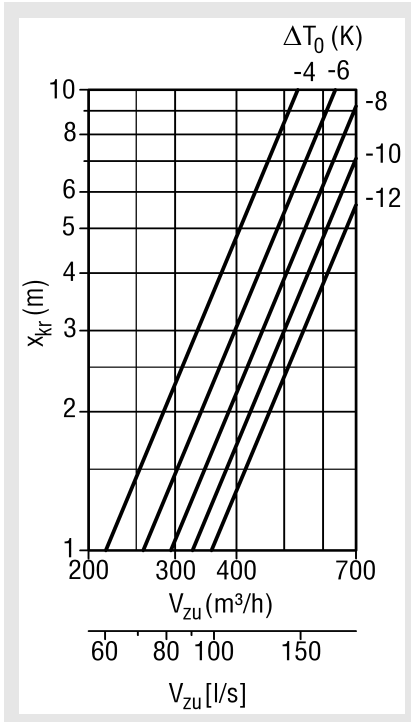

4DF-Z-500-...

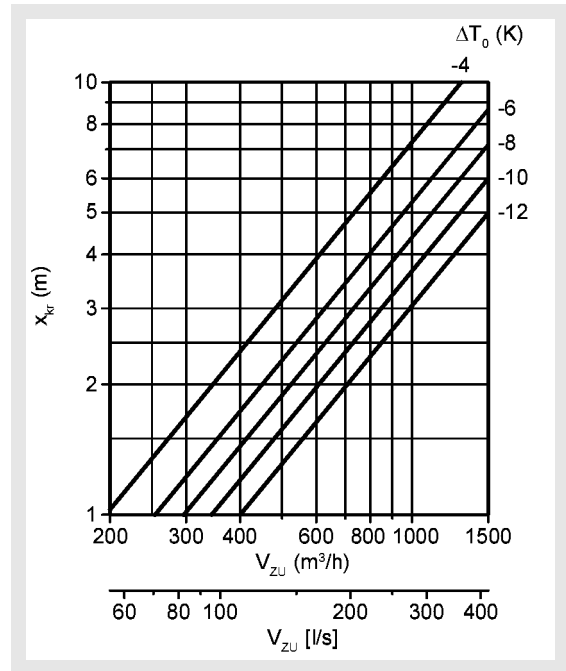

4DF-Z-600/625-...

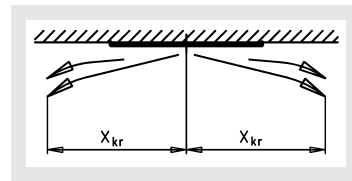
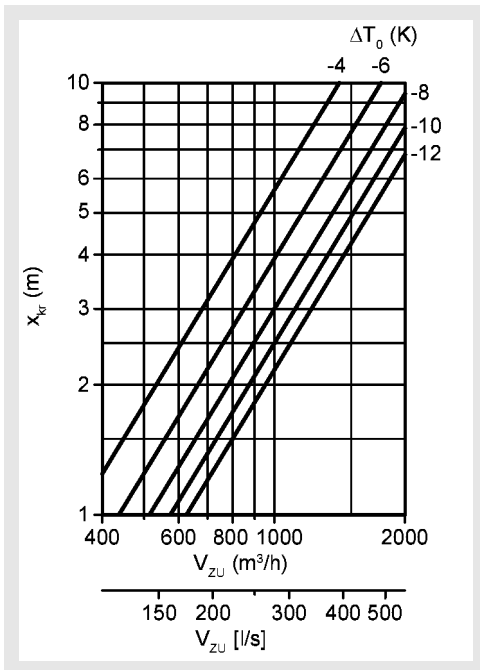

Ceiling diffuser 4DF

Induction ratios

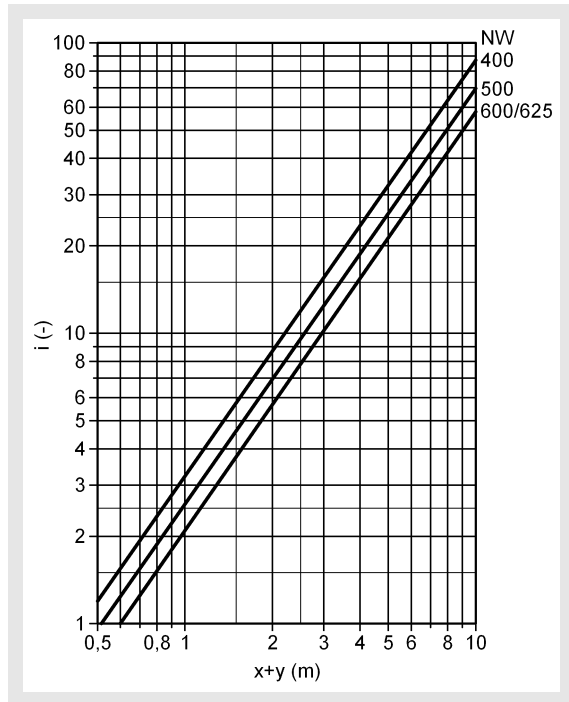

Temperature ratios

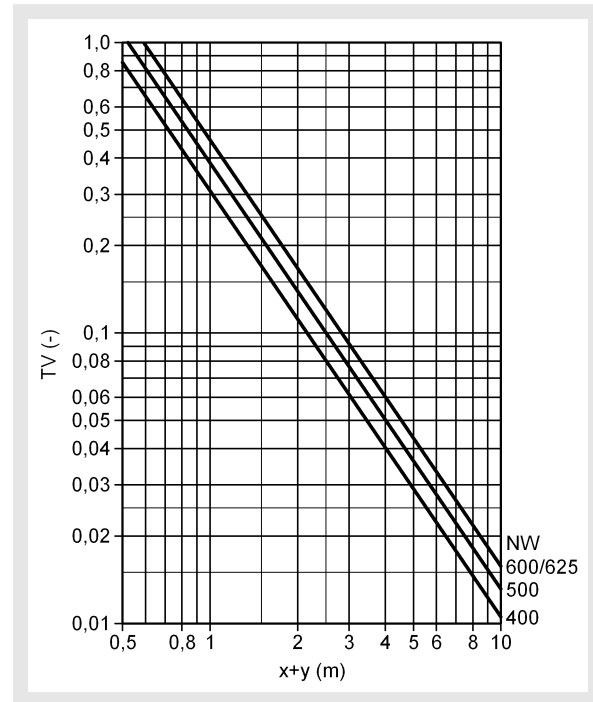

Legend

V_{ZU} (m^3/h)	=	Supply air volume
V_{ZU} [l/s]	=	Supply air volume
V_{AB} (m^3/h)	=	Return air volume
V_{AB} [l/s]	=	Return air volume
Δp_t (Pa)	=	Pressure loss
L_{WA} [dB(A)]	=	A-weighted sound power level
ρ (kg/m^3)	=	Density
v_{max} (m/s)	=	Maximum end velocity of jet
v (m/s)	=	Average end velocity of jet ($v = v_{max} \times 0.5$)
$x+y$ (m)	=	Horizontal + vertical throw
x_{kr} (m)	=	critical throw
ΔT_0 (K)	=	Temperature difference between supply air temperature and room temperature ($\Delta T_0 = t_{ZU} - t_R$)
t_{ZU} (K)	=	Supply air temperature
t_R (K)	=	Room temperature
i (-)	=	Induction ratio ($i = V_X / V_{ZU}$)
TV (-)	=	Temperature ratio ($TV = \Delta T_X / \Delta T_0$)
NW (mm)	=	Nominal width
ΔT_X (K)	=	Temperature difference at point x
V_X (m^3/h)	=	Total air jet volume at point x
V_X [l/s]	=	Total air jet volume at point x

Ceiling diffuser 4DF

Order details 4DF

01	02	03	04	05	06
Type	Air throw	Nominal size	Material	Paint	Mounting
Example					
4DF	-Z	-500	-SB	-9010	-VM

Sample

4DF-Z-500-SB-9010-VM

Ceiling diffuser type 4DF | supply air | NW500 | faceplate made of sheet steel | faceplate painted to RAL9010 | concealed mounting

Order details

01 - Type

4DF = Ceiling diffuser

02 - Air throw

Z = Supply air

A = return air

03 – Nominal size

310 = NW310

400 = NW400

500 = NW500

600 = NW600

625 = NW625

04 - Material

SB = Sheet steel

05 - Paint

9010 = RAL colour white (standard)

xxxx = RAL colour can be freely selected

06 - Mounting

VM = concealed mounting (only possible in combination with SK-...)

Ceiling diffuser 4DF

Order details SK

01	02	03	04	05	06	07	08	09
Plenum box	Model	Air diffuser	Type of air	Nominal size	Fastening	Material	Damper	Rubber lip seal
Example								
SK	-Q	-07	-Z	-500	-VM	-SV	-DK1	-GD1

10	11	12	13	14	15
Volumetric flow meter	ROB version	Insulation	Height of box	Spigot diameter	Spigot position
-VME1	-ROB0	-I0	-KHS	-SDS	-S1

Sample

SK-Q-07-Z-500-VM-SV-DK1-GD1-VME1-ROB0-I0-KHS-SDS-S1

Plenum box, square design | for square air diffusers | ceiling diffuser 4DF | supply air | NW500 | with concealed mounting | galvanised sheet steel | with damper | with rubber lip seal | with volumetric flow meter | without ROB model | without box insulation | standard height of plenum box | standard spigot diameter | 1 lateral spigot

Order details

01 - Plenum box

SK = Plenum box, square design

02 - Model

Q = for square air diffusers

03 - Air diffuser (must be ordered separately)

07 = suitable for 4DF-...

04 - Type of air

Z = Supply air

A = return air

05 - Nominal size

310 = NW310

400 = NW400

500 = NW500

600 = NW600

625 = NW625

06 - Fastening

VM = Concealed mounting (standard)

07 - Material

SV = Galvanised sheet steel (standard)

08 - Damper

DK0 = without damper (standard)

DK1 = with damper

DK2 = with damper + cable

09 - Rubber lip seal

GD0 = without rubber lip seal (standard)

GD1 = with rubber lip seal

10 - Volumetric flow meter

VME0 = without volumetric flow meter (standard)

VME1 = With volumetric flow meter

11 - ROB version

ROB0 = Without ROB version (standard)

ROB1 = With ROB version

12 - Insulation

I0 = without insulation (standard)

Ii = With box insulation inside

Ia = With box insulation outside

Ceiling diffuser 4DF

13 - Height of box

KHS = Height of plenum box standard

xxx = height of plenum box in mm ($\text{height}_{\text{min}}$ = spigot diameter + +102 mm, but at least 200 mm) (For models SK-Q-07-Z-310 / -400-...-DK1/-DK2-...-S0, observe special height of plenum box (see p. 5))

14 - Spigot diameter

SDS = Standard spigot diameter

xxx = Spigot diameter in mm

15 - Spigot position

S0 = Spigot from above

S1 = 1 lateral spigot on the box (standard)

S2 = 2 spigots offset by 90°

S3 = 2 spigots offset by 180°

S5 = 2 spigots arranged next to each other

Ceiling diffuser 4DF

Specification texts

Ceiling diffuser **type 4DF** for supply and return air, horizontal throw in 4 directions. Particularly suitable for installation in comfort rooms with high number of air changes, for clean rooms (in connection with particle filter boxes) and for VAV installations with variable volumetric flows (between 40-100%). Consisting of square sheet steel faceplate painted with a high-quality powder coating to a RAL colour (RAL 9010, white, standard), with integrated fixed air deflection blades, with concealed mounting (VM). For use in isothermal mode and in cooling mode (up to -14 K) and a room height of 2 - 4.5 m. Sophisticated design allows easy cleaning to VDI 6022.

Product: SCHAKO **type 4DF-...**

Accessories:

- Plenum box (SK-Q-...) made of galvanised sheet steel, with fixing lugs (only available in conjunction with concealed mounting) (-Z).
 - Supply air model with integrated perforated straightener (-A).
 - Return air model without perforated straightener.
 - with damper (-DK1/-DK2) in plenum box, adjustable from below, for simple air volume regulation without dismantling the faceplate.
 - with damper without cable-operated adjustment (-DK1)
 - with damper with cable-operated adjustment (-DK2)
 - with volumetric flow meter (-VME1).
 - with ROB model (-ROB1), removable diffuser plate, damper and volumetric flow meter.
 - with rubber lip seal (-GD1), on plenum box spigot, made of special rubber.
 - with thermal insulation
 - internal (-li)
 - external (-la)
 - height of plenum box can be freely selected, xxx in mm, ($\text{height}_{\min} = \text{spigot diameter} + 102 \text{ mm}$, but at least 200 mm) (For models SK-Q-07-Z-310 / -400-...-DK1/-DK2-...-S0, observe special height of plenum box (see p. 5))
 - Spigot diameter can be freely selected, xxx in mm
 - Spigot position
 - S0 = spigot from above
 - S1 = 1 lateral spigot on the box (standard)
 - S2 = 2 spigots offset by 90°
 - S3 = 2 spigots offset by 180°
 - S5 = 2 spigots arranged next to each other